

Air line equipment

Excelon® Modular System

F72G, F73G, F74G General Purpose Filters

Excelon® design allows in-line installation or modular installation with other Excelon® products

Quick release bayonet bowl

Optional service life indicator turns from green to red when the filter element needs to be replaced

Technical data

Fluid:

Compressed air

Operating pressure:

Transparent bowl: 150 psig

Metal bowl: 250 psig

Automatic drain: 150 psig

Operating temperature*:

Transparent bowl: -30° to 125°F

Metal bowl: -30° to 150°F

* Air supply must be dry enough to avoid ice formation at temperatures below 35°F.

Materials

F72G

Body: zinc

Transparent bowl: polycarbonate

Guard for transparent bowl: zinc

Metal bowl: zinc

Metal bowl liquid level indicator lens: transparent nylon

Element: sintered polypropylene

Elastomers: neoprene and nitrile

F73G & F74G:

Body: aluminum

Transparent bowl: polycarbonate

Transparent with guard: polycarbonate, steel guard

Metal bowl: aluminum

Metal bowl liquid level indicator lens: transparent nylon

Element: sintered polypropylene



F72G



F73G



F74G

Ordering information

Models listed include PTF threads, automatic drain, metal bowl with liquid level indicator, and a 40 µm element.

Port Size	Model	Flow† scfm (dm3/s)	Weight lb (kg)
1/4"	F72G 2AN AL3	55 (26)	1.15 (0.52)
3/8"	F72G 3AN AL3	55 (26)	1.15 (0.52)
1/4"	F73G 2AN AD3	53 (25)	1.1 (0.50)
3/8"	F73G 3AN AD3	65 (31)	1.1 (0.50)
1/2"	F73G 4AN AD3	69 (33)	1.1 (0.50)
3/8"	F74G 3AN AD3	112 (53)	1.82 (0.83)
1/2"	F74G 4AN AD3	140 (66)	1.79 (0.81)
3/4"	F74G 6AN AD3	140 (66)	1.75 (0.79)

† Typical flow with a 40µm element at 90 psig (6.3 bar) inlet pressure and 5 psig (0.35 bar) pressure drop.

Options selector

Series	Substitute	Element	Substitute
72	2	5 µm	1
73	3	40 µm	3
74	4		
Port size	Substitute	Bowl	Substitute
1/4 (72, 73)	2	Metal w/ liquid level indicator (72, 73, 74)	D
3/8 (72, 73 74)	3	Long metal w/ liquid level indicator (72)	E
1/2 (73, 74)	4	Long transparent without guard (72)	L
3/4 (74)	6	Transparent with guard (73, 74)	P
		Transparent bowl (72, 73)	T
		Long transparent with guard (72)	W
Threads	Substitute	Drain	Substitute
PTF	A	1/4 turn manual	Q
ISO G parallel	G	Auto drain*	A
Service life indicator	Substitute		
With (visual)	D		
With (electrical)	E		
Without	N		

* 72 Series auto drain is available only with long bowl option.

Excelon® Modular System

F72G, F73G, F74G General Purpose Filters

Dimensions in inches

Accessories*

	Wall mounting bracket**	Quikmount pipe adapters (quantity of 1) (NPT)	Quikclamp®†	Quikclamp® and wall bracket	Service life indicator	Electrical service life indicator
F72G	4224-50	4215-02 (1/4) 4215-03 (3/8)	4214-51	4214-52 4213-89*	5797-50	4020-51R
F73G	4424-50	4315-01 (1/4) 4315-02 (3/8) 4315-03 (1/2) 4315-04 (3/4)	4314-51	4314-52 4313-50*	5797-50	4020-51R
F74G	4324-50	4315-02 (3/8) 4315-03 (1/2) 4315-04 (3/4)	4314-51	4314-52 4313-50*	5797-50	4020-51R

* For additional options see website.

** Bracket only.

† Quikclamp is patented (US patent 5372392) and foreign patents.

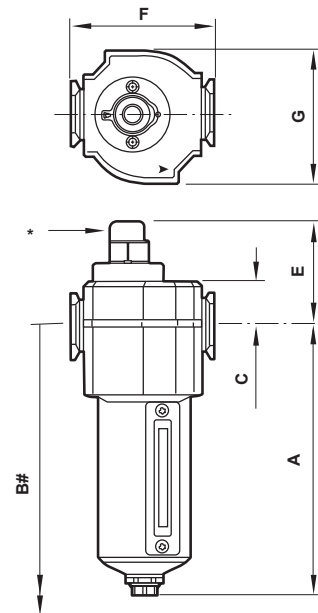

Auto drain

* Optional service indicator

Minimum clearance required to remove bowl

Service Kit			
Item	Type	Part Number	
72G	Seal and Gasket	4380-500	
73G	Seal and Gasket	4380-600	
74G	Seal and Gasket	4380-700	

Series	Drain type	A	B	C	E	F	G
72	Auto	5.98	7.99	0.75	2.09	1.97	1.89
	Manual	5.28	7.28	0.75	2.09	1.97	1.89
73	Auto	6.48	8.84	0.98	2.36	2.68	2.44
	Manual	6.14	8.50	0.98	2.36	2.68	2.44
74	Auto	7.03	9.75	0.98	2.36	3.15	2.91
	Manual	6.97	9.69	0.98	2.36	3.15	2.91

Mounting bracket

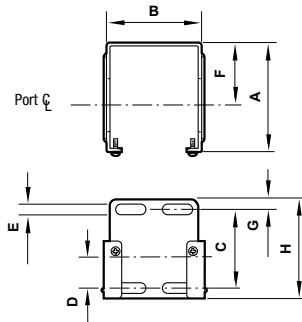

	A	B	C	D	E	F	G	H
72	2.36	1.65	1.54	0.73	0.16	1.50	0.24	2.01
73	2.64	2.36	1.89	0.75	0.28	1.50	0.24	2.40
74	3.11	2.72	1.97	0.79	0.20	2.01	0.24	2.40

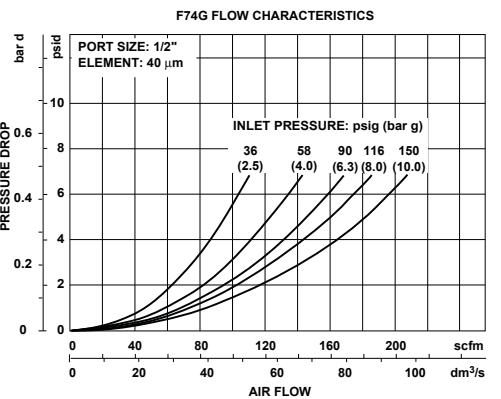
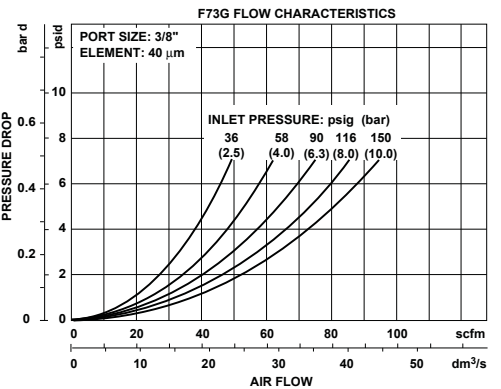
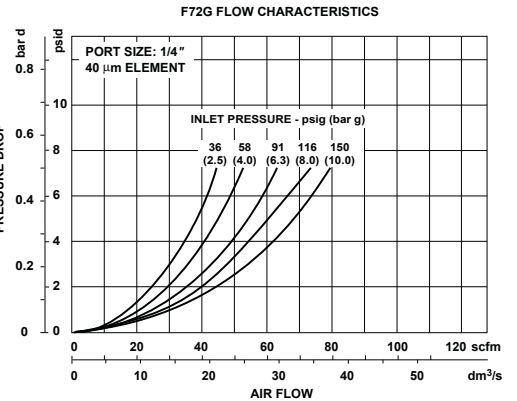

Air line equipment

Excelon® Modular System

F72C, F73C, F74C, F74H Oil Removal (Coalescing) Filters

Excelon® design allows in-line or modular installation
High efficiency oil and particle removal
Quick release bayonet bowl
Standard visual service life indicator turns from green to red when the filter element needs to be replaced
Technical data

Fluid:

Compressed air

Maximum pressure:

Transparent bowl: Manual or semi automatic drain: 150 psig (10 bar)

Automatic drain: 116 psig (8 bar)

Metal bowl: manual or semi automatic drain: 250 psig (17 bar)

Automatic drain: 116 psig (8 bar)

Operating temperature*:

Transparent bowl:

-30° to 125°F (-34° to 50°C)

Metal bowl:

-30° to 150°F (-34° to 65°C)

* Air supply must be dry enough to avoid ice formation at temperatures below 35°F (2°C).

Particle removal:

0.01 µm

Materials

F72C

Body: zinc

Bowl transparent: polycarbonate

Guard for transparent bowl: zinc

Metal: zinc

Metal bowl liquid level indicator lens:

Transparent nylon

Element: synthetic fiber and polyurethane foam

Elastomers: neoprene and nitrile

Service life indicator materials-Body: transparent nylon.

Internal parts: acetal.

Spring: stainless steel.

Elastomers: nitrile

F73C and F74C

Body: aluminum

Transparent bowl: polycarbonate

Transparent with guard: polycarbonate, steel guard

Metal bowl: aluminum

Metal bowl liquid level indicator lens:

Transparent nylon

Element: synthetic fiber and polyurethane foam

Elastomers: neoprene and nitrile

Mechanical service indicator materials

Body: transparent nylon

Internal parts: Acetal

Spring: Stainless steel

Elastomers: Nitrile



F72C



F73C



F74C

Ordering Information

Models listed include PTF threads, service indicator, automatic drain, and a metal bowl with liquid level indicator.

Port Size	Model Number	Maximum Flow* scfm (dm3/s)	Weight lb (kg)
1/4"	F72C 2AD AL0	9.5 (4.5)	1.2 (0.54)
3/8"	F72C 3AD AL0	9.5 (4.5)	1.2 (0.54)
1/4"	F73C 2AD AD0	21.2 (10.0)	1.2 (0.54)
3/8"	F73C 3AD AD0	21.2 (10.0)	1.2 (0.54)
1/2"	F73C 4AD AD0	21.2 (10.0)	1.2 (0.54)
3/8"	F74C 3AD AD0(std)	33.9 (16.0)	1.88 (0.85)
1/2"	F74C 4AD AD0(std)	33.9 (16.0)	1.84 (0.83)
1/2"	F74H 4AD AD0 (hi)	59.3 (28.0)	2.45 (1.11)
3/4"	F74H 6AD AD0 (hi)	59.3 (28.0)	2.40 (1.10)

* Maximum flow with 90 psig (6.3 bar) inlet pressure to maintain stated oil removal performance.

Options selector

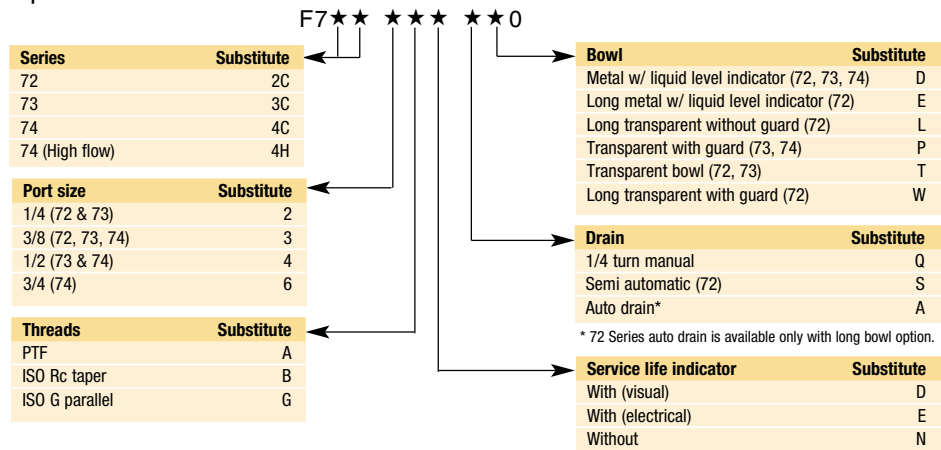

Excelon® Modular System

F72C, F73C, F74C, F74H Oil Removal (Coalescing) Filters

Dimensions in inches.

Accessories*

	Wall mounting bracket**	Quikmount pipe adapters (quantity of 1) (NPT)	Quikclamp®†	Quikclamp® and wall bracket	Service life indicator	Electrical service life indicator
F72C	4224-50	4215-02 (1/4) 4215-03 (3/8)	4214-51	4214-52 4213-89*	5797-50	4020-51R
F73C	4424-50	4315-01 (1/4) 4315-02 (3/8) 4315-03 (1/2) 4315-04 (3/4)	4314-51	4314-52 4313-50*	5797-50	4020-51R
F74C, F74H	4324-50	4315-02 (3/8) 4315-03 (1/2) 4315-04 (3/4)	4314-51	4314-52 4313-50*	5797-50	4020-51R

* For additional options see website.

**Bracket only.

† Quikclamp is patented (US patent 5372392) and foreign patents.

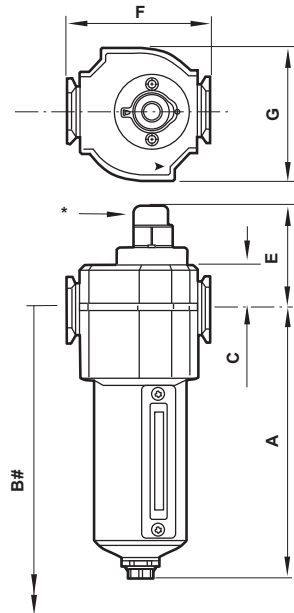

* Standard service indicator

Minimum clearance required to remove bowl

Mounting bracket

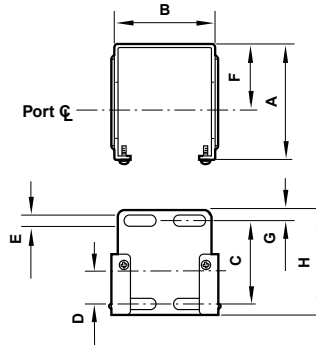

Service Kit			
Item	Type	Part Number	
72C	Seal and Gasket	4380-500	
73C	Seal and Gasket	4380-602	
74C/H	Seal and Gasket	4380-730	

Series	A	B	C	D	E	F	G	H
72	2.36	1.65	1.54	0.73	0.16	1.50	0.24	2.01
73	2.64	2.36	1.89	0.75	0.28	1.50	0.24	2.40
74	3.11	2.72	1.97	0.79	0.20	2.01	0.24	2.40

Series	Drain type	A	B	C	E	F	G
F72C	Auto	5.98	7.99	0.75	2.09	1.97	1.89
	Manual	5.28	7.28	0.75	2.09	1.97	1.89
F73C	Auto	6.48	8.84	0.98	2.36	2.68	2.44
	Manual	6.14	8.50	0.98	2.36	2.68	2.44
F74C	Auto	7.03	9.75	0.98	2.36	3.15	2.91
	Manual	6.97	9.69	0.98	2.36	3.15	2.91
F74H	Auto	9.15	11.87	0.98	2.36	3.15	2.91
	Manual	9.06	11.81	0.98	2.36	3.15	2.91

F72

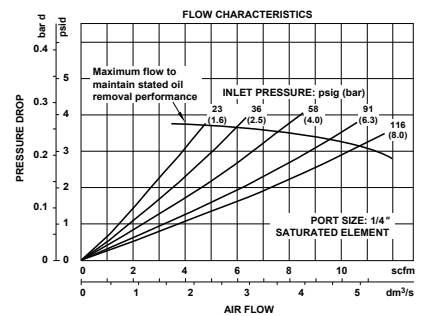

F73

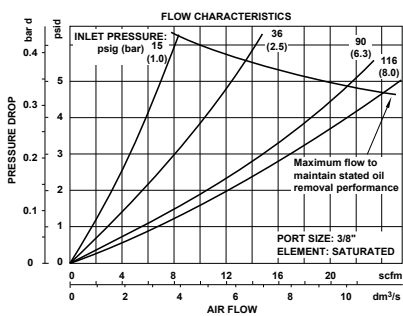

F74C

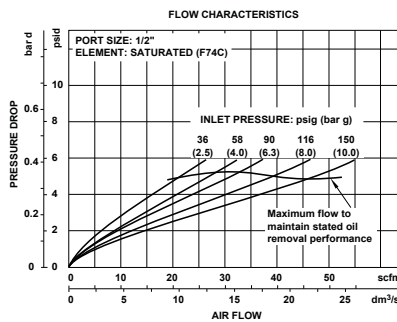

F74H

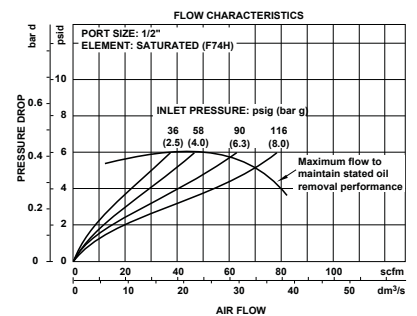

Air line equipment

Excelon® Modular System

F72V, and F74V Oil Vapor Removal (adsorbing) Filters

Excelon® design allows in-line or modular installation
Adsorbing type activated carbon element removes oil vapors and most hydrocarbon odors
Quick release bayonet bowl
Long service life of filter element.
Modular installations with Excelon® 72, 73, and 74 series can be made to suit particular applications

Technical data

Fluid:

Compressed air

Maximum pressure:

Transparent bowl: 150 psig (10 bar)

Metal bowl: 250 psig (17 bar)

Operating temperature*:

Transparent bowl:

0° to 125°F (-20° to 50°C)

Metal bowl:

0° to 150°F (-20° to 65°C)

* Air supply must be dry enough to avoid ice formation at temperatures below 35°F (2°C)

Air quality:

Within ISO 8573-1, Class 1 ** (oil content) when installed downstream of an oil removal filter

** See website for specification details.

Maximum remaining oil content in outlet air:

0.003 ppm at 70°F (20°C)

Materials

F72V

Body: zinc

Transparent bowl: polycarbonate

Guard for transparent bowl: zinc

Metal bowl: zinc

Element: Activated carbon and polycarbonate

Elastomers: nitrile

F74V

Body: aluminum

Transparent Bowl: polycarbonate with steel bowl guard

Metal bowl: aluminum

Element: activated carbon and aluminum

Elastomers: neoprene and nitrile



F72V



F74V

Ordering Information

Models listed include PTF threads, service indicator, automatic drain, and a metal bowl with liquid level indicator.

Port Size	Model	Flow* scfm (dm3/s)	Weight lb (kg)
1/4"	F72V 2AN ELC	3.4 (1.6)	0.88 (0.40)
3/8"	F72V 3AN ELC	3.4 (1.6)	0.88 (0.40)
3/8"	F74V 3AN EMA	21 (10)	2.54 (1.15)
1/2"	F74V 4AN EMA	21 (10)	2.51 (1.14)
3/4"	F74V 6AN EMA	21 (10)	2.46 (1.12)

* Maximum flow with 90 psig (6.3 bar) inlet pressure to maintain stated oil removal performance.

Options selector

Series	Substitute	Element	Substitute
72	2	Activated carbon	A
74	4	Activated carbon w/color indicator (72)	C
Port size	Substitute	Bowl	Substitute
1/4 (72)	2	Metal (72)	C
3/8 (72, 74)	3	Long transparent without guard (72)	L
1/2 (74)	4	Long transparent with guard (72)	W
3/4 (74)	6	Metal (74)	M
		Transparent with guard (74)	P
Threads	Substitute	Drain	Substitute
PTF	A	Closed bottom (no drain)	E
ISO Rc taper	B		
ISO G parallel	G		
		Options	Substitute
		No option	N

Oil vapor removal filters must be protected upstream by an oil removal filter.

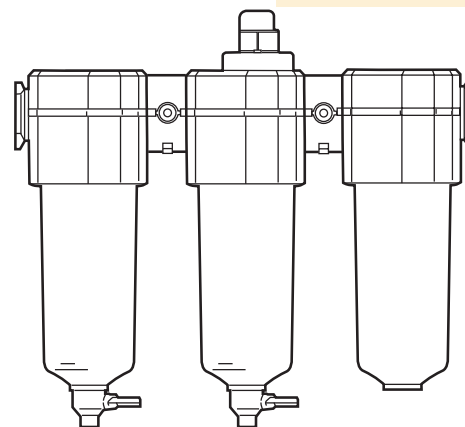

General purpose filter

Oil removal filter

Oil vapor removal filter

Excelon® Modular System F72V and F74V Oil Vapor Removal (adsorbing) Filters

Accessories*

	Wall mounting bracket**	Quikmount pipe adapters (quantity of 1) (NPT)	Quikclamp®	Quikclamp® and wall bracket
F72V	4224-50	4215-02 (1/4) 4215-03 (3/8)	4214-51	4214-52 4213-89*
F74V	4324-50	4315-02 (3/8) 4315-03 (1/2) 4315-04 (3/4)	4314-51	4314-52 4313-50*

Service Kit			
Item	Type	Part Number	
72V	Seal and Gasket	4380-500	
74V	Seal and Gasket	4380-750	

* For additional options see website.
** Bracket only.

Typical Performance Characteristics

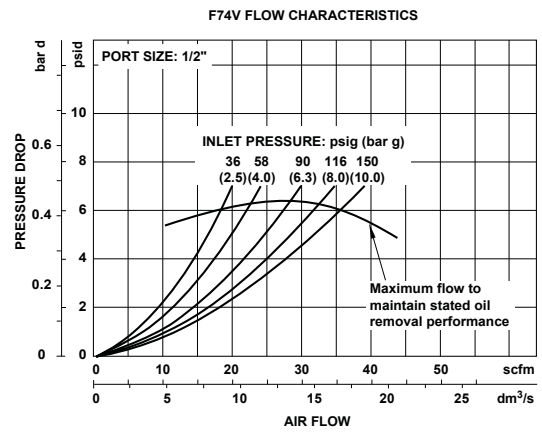
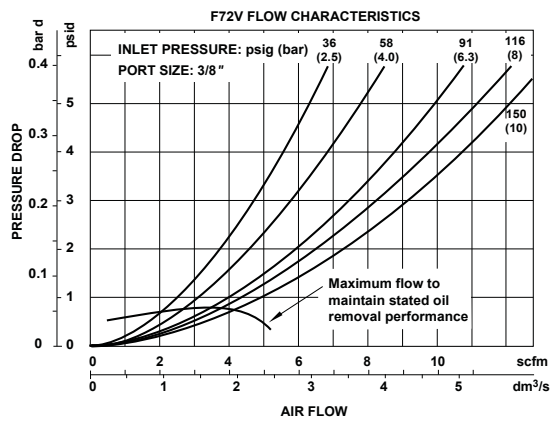

Mounting bracket

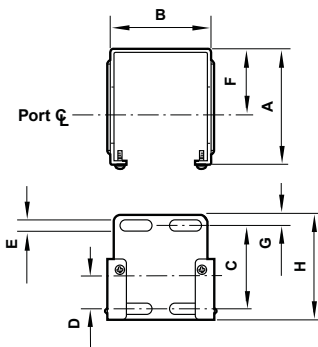

Series	A	B	C	D	E	F	G	H
72	2.36	1.65	1.54	0.73	0.16	1.50	0.24	2.01
74	3.11	2.72	1.97	0.79	0.20	2.01	0.24	2.40

All Dimensions in Inches (mm)

F72V

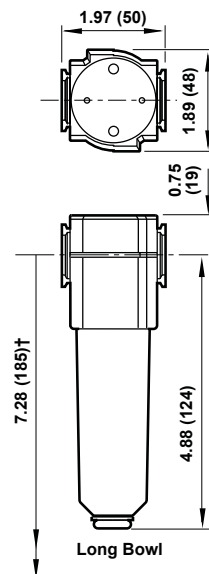

† Minimum clearance required to remove bowl.

F74V

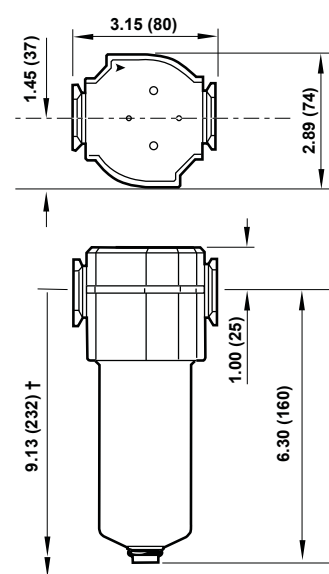

† Minimum clearance required to remove bowl.

Air line equipment

Excelon® modular system

B72G, B73G, B74G Filter/Regulators

Excelon® design allows in-line installation or modular installation with other Excelon® products

High efficiency water and particle removal

Quick release bayonet bowl

Push to lock adjusting knob with tamper resistant accessory

Optional patented quarter turn manual drain

Technical data

Fluid:

Compressed air

Maximum pressure:

Transparent bowl: 150 psig (10 bar)

Metal bowl: 250 psig (17 bar)

B72G with metal bowl & auto drain: 150 psig (10 bar)

Operating temperature*:

Transparent bowl:

-30° to 125°F (-34° to 50°C)

Metal bowl:

-30° to 175°F (-34° to 80°C)

* Air supply must be dry enough to avoid ice formation at temperatures below 35°F (2°C).

Materials

B72G

Body: zinc

Bonnet: acetal

Valve: brass

Transparent bowl: polycarbonate

Metal bowl: zinc

Liquid level indicator lens (metal bowl):

transparent nylon

Element: sintered polypropylene

Elastomers: neoprene & nitrile

B73G & B74G:

Body & bonnet: aluminum

Transparent bowl: polycarbonate

Guarded transparent bowl:

polycarbonate with steel

Metal bowl: aluminum

Liquid level indicator lens (metal bowl):

transparent nylon (Pyrex optional)

Element: sintered polypropylene

Elastomers: neoprene & nitrile



B72G



B73G



B74G

Ordering Information

Models listed include PTF threads, knob adjustment, automatic drain, metal bowl with liquid level indicator, 40 µm element, relieving diaphragm, 5 to 150 psig (0.3 to 10 bar) outlet pressure adjustment range* with gauge.

Port Size	Model	Flow† scfm (dm3/s)	Weight lb (kg)
1/4"	B72G 2AK AE3 RMG	80 (38)	1.3 (0.59)
3/8"	B72G 3AK AE3 RMG	80 (38)	1.3 (0.59)
1/4"	B73G 2AK AD3 RMG	78 (37)	1.76 (0.82)
3/8"	B73G 3AK AD3 RMG	123 (58)	1.76 (0.82)
1/2"	B73G 4AK AD3 RMG	123 (58)	1.76 (0.82)
3/8"	B74G 3AK AD3 RMG	163 (77)	2.62 (1.19)
1/2"	B74G 4AK AD3 RMG	212 (100)	2.59 (1.17)
3/4"	B74G 6AK AD3 RMG	212 (100)	2.55 (1.16)

*Outlet pressure can be adjusted to pressures in excess of, and less than, those specified. Do not use these units to control pressures outside of the specified ranges.

† Typical flow with 150 psig (10 bar) inlet pressure, 90 psig (6.3 bar) set pressure and a 15 psig (1 bar) droop from set.

Options selector

		B7★G ★★ ★★ ★★ ★★			
Series	Substitute			Gauge	Substitute
72	2			With	G
73	3			Without	N
74	4				
Port size	Substitute			Outlet pressure adjustment range*	Substitute
1/4" (72 & 73)	2			5 to 30 psig 0.3 to 2 bar (72)	C
3/8" (72, 73, 74)	3			5 to 60 psig (0.3 to 4 bar)	F
1/2" (73 & 74)	4			5 to 150 psig (0.3 to 10 bar)	M
3/4" (74)	6			10 to 250 psig (0.7 to 17 bar) (73, 74)**	S
Threads	Substitute			Diaphragm	Substitute
PTF	A			Relieving	R
ISO G parallel	G			Non relieving	N
Adjustment	Substitute			Element	Substitute
Knob	K			5 µm	1
T-bar	T			40 µm	3
Drain	Substitute			Bowl	Substitute
1/4 turn manual	Q			Metal w/ liquid level indicator (72, 73, 74)	D
Semi automatic (72)	S			Long metal w/ liquid level indicator (72)	E
Auto drain*	A			Long transparent without guard (72)	L
				Transparent with guard (73, 74)	P
				Transparent bowl (72, 73)	T
				Long transparent with guard (72)	W

*72 Series auto drain is available only with long bowl option.

*Outlet pressure can be adjusted to pressures in excess of, and less than, those specified. Do not use these units to control pressures outside of the specified ranges.

** 250 psig (17 bar) outlet pressure range units are available with t-handle adjustment and standard metal bowl options only.

Excelon® modular system

B72G, B73G, B74G Filter/Regulators

Dimensions in inches.

Accessories*

	Wall mounting bracket**	Neck mounting bracket	Gauge 0 ... 160 psig	Panel nut	Tamper resistant cover and seal wire	Pipe adapters (quantity of 1) (NPT)	Quikclamp®	Quikclamp® and wall bracket
B72G	4224-50	74316-50	18-013-212	4248-89	4255-51	4215-02 (1/4) 4215-03 (3/8)	4214-51	4214-52 4213-89*
B73G	4424-50	4461-50	18-013-209	5191-88	4455-51	4315-01 (1/4) 4315-02 (3/8) 4315-03 (1/2) 4315-04 (3/4)	4314-51	4314-52 4313-50*
B74G	4324-50	4368-51	18-013-209	4348-89	4355-51	4315-02 (3/8) 4315-03 (1/2) 4315-04 (3/4)	4314-51	4314-52 4313-50*

* For additional options see website. ** Bracket only.

Mounting bracket

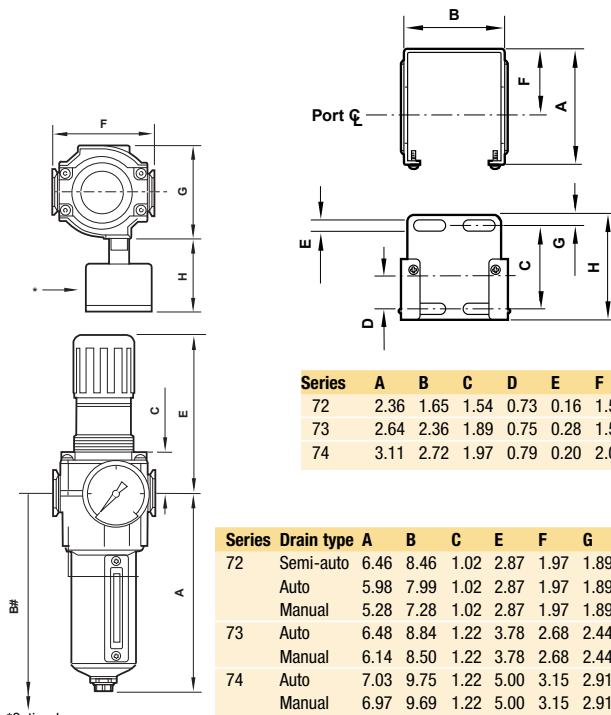

Neck mounting brackets

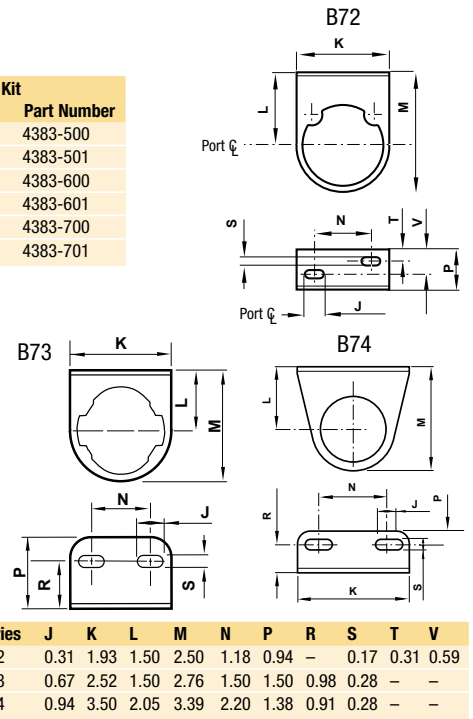

*Optional gauge.

Minimum clearance required to remove bowl.

Typical Performance Characteristics

