



## PU..A type flow control pressure compensated valves - 2 ways

- Line mounting
- From SAE08 to SAE16 cavities

Technical specifications and diagrams are measured with mineral oil of 46 cSt viscosity at 40°C (104°F) temperature.

	PU08A	PU10A	PU12A	PU16A
Nominal flow	15 l/min (3.9 US gpm)	30 l/min (7.9 US gpm)	50 l/min (13 US gpm)	90 l/min (24 US gpm)
Max. pressure	350 bar (5100 psi)			
Fluid	mineral based oil			
Viscosity	10-200 cSt			
Max level of contamination	20/18/14 ISO4406			
Fluid temperature	with NBR seals with FPM seals	from -20°C (-4°F) to 80°C (176°F) from -20°C (-4°F) to 100°C (212°F)		
Environmental temp. for working conditions	from -20°C (-4°F) to 50°C (122°F)			
Cavity	SAE 8/2 A	SAE 10/2 A	SAE 12/2 A	SAE 16/2 A
Weight	0.18 kg (0.40 lb)	0.20 kg (0.44 lb)	0.30 kg (0.66 lb)	0.55 kg (1.21 lb)

NOTE - For different conditions, please contact Walvoil Sales Dpt.

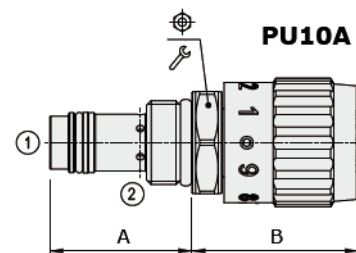
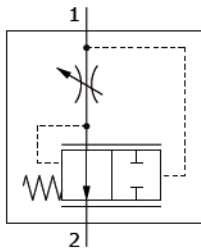

Valve type	A		B		⌀	Wrench icon	Nm	lbft
	mm	in	mm	in				
PU08A/AM	33.6	1.32	48.5	1.91	24	30	22	
PU10A/AM	37.5	1.48	43	1.69	27	50	36	
PU12A/AM	58.5	2.30	44	1.73	32	80	59	
PU16A/AM	68	2.68	52	2.05	41	100	74	

For dimensions with different type of adjustment see page 196

### Ordering codes and description composition

#### PU08A/AM0B

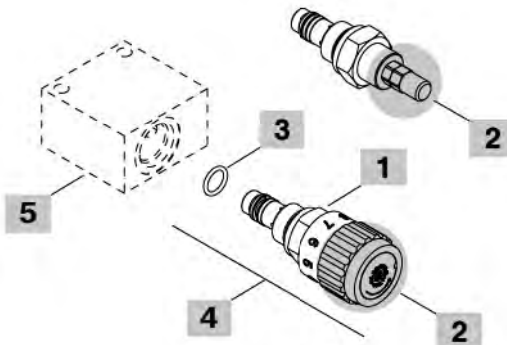
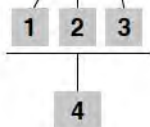

#### 1 Pressure drop from 1 to 2

TYPE	DESCRIPTION
A	12 bar (170 psi)

#### 2 Adjustments

TYPE	DESCRIPTION
S	Screw
M	Handknob

#### 3 Seals

TYPE	DESCRIPTION
B	<b>NBR (Buna)</b> Std configuration without addition
V	For valve with <b>FPM (Viton)</b> o-ring seals, contact Sales Dept.

#### 4 Cartridges

TYPE	CODE	DESCRIPTION
<b>SAE cavity 8/2</b>		
PU08A/AM0B	0PU08002000	Handknob adjustment
PU08A/AS0B	0PU08002003	Screw type adjustment
<b>SAE cavity 10/2</b>		
PU10A/AM0B	0PU10002001	Handknob adjustment
PU10A/AS0B	0PU10002000	Screw type adjustment
<b>SAE cavity 12/2</b>		
PU12A/AM0B	0PU12002000	Handknob adjustment
PU12A/AS0B	0PU12002003	Screw type adjustment
<b>SAE cavity 16/2</b>		
PU16A/AM0B	0PU16002000	Handknob adjustment
PU16A/AS0B	0PU16002007	Screw type adjustment

#### 5 Valve body

TYPE	CODE	DESCRIPTION
<b>SAE 08/2-G 3/8</b>	3CC0820C11	Aluminium body for cavity 8 valve G3/8 std thread
<b>SAE 10/2-G 3/8</b>	3CC1020C11	Aluminium body for cavity 10 valve G3/8 std thread
<b>SAE 12/2-G 1/2</b>	3CC1220D11	Aluminium body for cavity 12 valve G1/2 std thread
<b>SAE 16/2-G 3/4</b>	3CC1620E11	Aluminium body for cavity 16 valve G3/4 std thread

Note: aluminium body can stand up to 210 bar (3050 psi)  
For steel bodies or different threading see from page 199

