

**GO SILENTLY
AT HIGH PRESSURE
& HIGH SPEED**



CONTINUUM[®] Series

Helical rotor pumps for high pressure and no noise application

The new generation of gear pumps for
NO PULSATION & NO NOISE



INDUSTRIAL



MOBILE



MARINE

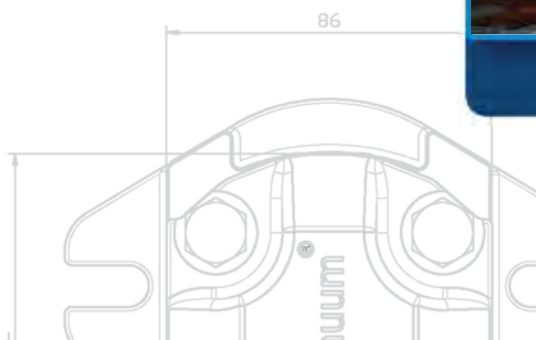
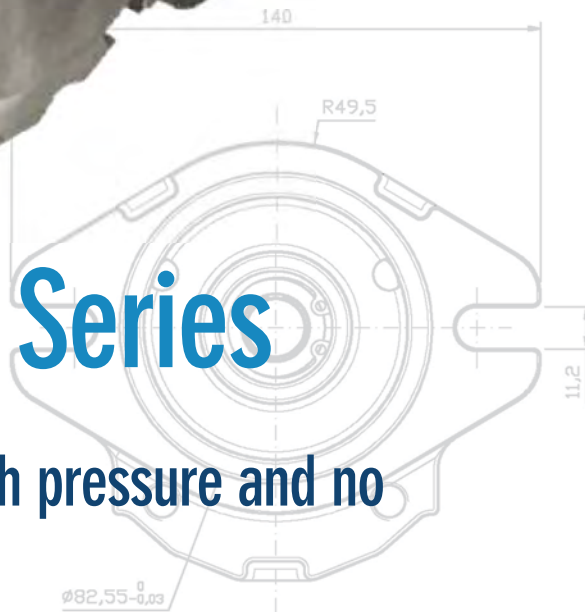

Achieves better efficiency, lower production cost, better life quality for the industrial world.
Ottiene alti livelli di efficienza, ridotti costi di produzione ed una migliore qualità del lavoro.

Reducing noise in the workplace has become a necessity for many companies. By now most companies have recognized noise as a cost weighting on the economics of their businesses. Noise pollution remains a serious problem to be solved for both stationary and mobile machinery. Hydraulic pumps, above all those for high pressure, entail unacceptable noise and/or vibration levels in many different applications. Up to now the noise problem has always been approached in the only possible way: with secondary and expensive activities such as using pulsation dampers, hoses, damping rails and rings, encapsulating the hydraulic components or the entire system and so on. **SETTIMA** decided to start to design a new gear pumps generation capable to reduce as much as possible the acoustic emissions and the consequent vibration level. Some years ago the result was the **Continuum® pump series**, able to reduce down to 52 dB(A) the normal operation noise. Today **SETTIMA** presents the new generation of **Continuum® pumps**, silent as always, but much more efficient and with longer lifetime even at heavy duty, at all pressure and speed ranges.

The most important economic benefits of using **Continuum® pumps** are:

- very low pump pulsations reduce dramatically also vibrations with no dispersion of energy,
- saving money respect to the more expensive traditional pumps such as piston pumps and internal gear pumps,
- high volumetric efficiency, also at very low speed, contributes to cost reduction and also enables the pump to be driven by motor at a variable velocity with consequent energy saving,
- cost saving by eliminating second noise reduction measures,
- keeping the same external dimensions of gear pump, with no necessity to redesign the system in case of replacement.

COMPETITIVE ANALYSIS / ANALISI COMPETITIVA

Continuum® pump is a valid alternative to silently replace different traditional solutions of noisy high pressure pump.

Continuum® pump can replace the following types of high pressure pumps:

- External gear pumps
- Internal gear pumps
- Fixed displacement vane pumps
- Fixed displacement piston pumps

Please contact Settima for all information about any possible replacement.



ORIGIN OF NOISE AND VIBRATIONS KNOCKED DOWN BY CONTINUUM® PUMP / LA POMPA CONTINUUM® HA ELIMINATO LE ORIGINI DEL RUMORE E DELLE VIBRAZIONI

The typical sound emissions of gear pumps have two distinct origins: mechanical noise and hydraulic noise. The mechanical noise is what can be expected from any pair of gears. The hydraulic noise, however, is generated by the perturbations of fluid pressure through the pump. This noise and/or vibration comes from three basic components:

- cavitation, that can cause serious noise in addition to structural damage to mechanical components
- the peak pressure that arises from trapping of fluid between the top and the bottom of the tooth,
- the "ripple" or the flow pulsation during meshing that causes pressure pulsation.

The continuous contact helical rotor **Continuum® pump** has solved these problems with sophisticated and efficient systems.

THINK DIFFERENT: THE SILENT AND UNIQUE REVOLUTION OF CONTINUUM® PUMP / UNA RIVOLUZIONE SILENZIOSA: LA POMPA CONTINUUM®

As for classic gear pumps, the transport flow is perpendicular to the axes, but the rotors profile, specially developed and internationally patented, does not trap any volume since the helical design of the profile plays the role of completing an overlap, making a gentle transmission of fluid resulting in a dramatic reduction of pulsation. There is just a single point of contact between the profiles during rotation, which eliminates the pockets acting on the axial thrust washer and the noise associated with this problem.

The Continuum® core and its technological innovation is based on three patented breakthroughs:

- The rotor profile
- The screw step
- The inner force balancing.

MANUFACTURING ACCURACY IN ANY DETAILS / MASSIMA ACCURATEZZA NEI DETTAGLI

SETTIMA produces hydraulic no noise pumps since over thirty years, achieving a high level of competence and accuracy in the manufacture of high-precision hydraulic pump drives.

Together with top production machineries, efficient test environments, 3D drawing capability and special materials for rotors and bushings, **SETTIMA** constantly achieves products of high quality that is the industry standard.

CONTINUUM® PUMP ADVANTAGES / VANTAGGI DELLA POMPA CONTINUUM®

- Low noise also at high speed (up to 6.500 RPM).
- Average of 15dB(A) less noisy than standard external gear pumps.
- Reduced noise level for the machine operator and surroundings.
- Cost saving by eliminating second noise reduction measures.
- Easy to replace - compatible with all external gear pumps.
- Helps meet legal noise requirements.
- Continuous variable flow rate (0% to 100%).
- Intermittent operation at high pressure & low speed.
- High volumetrical efficiency.

PULSATIONS LEVEL GRAPH / GRAFICO PULSAZIONI (100 bar - 40 cSt - 1.500 rpm)

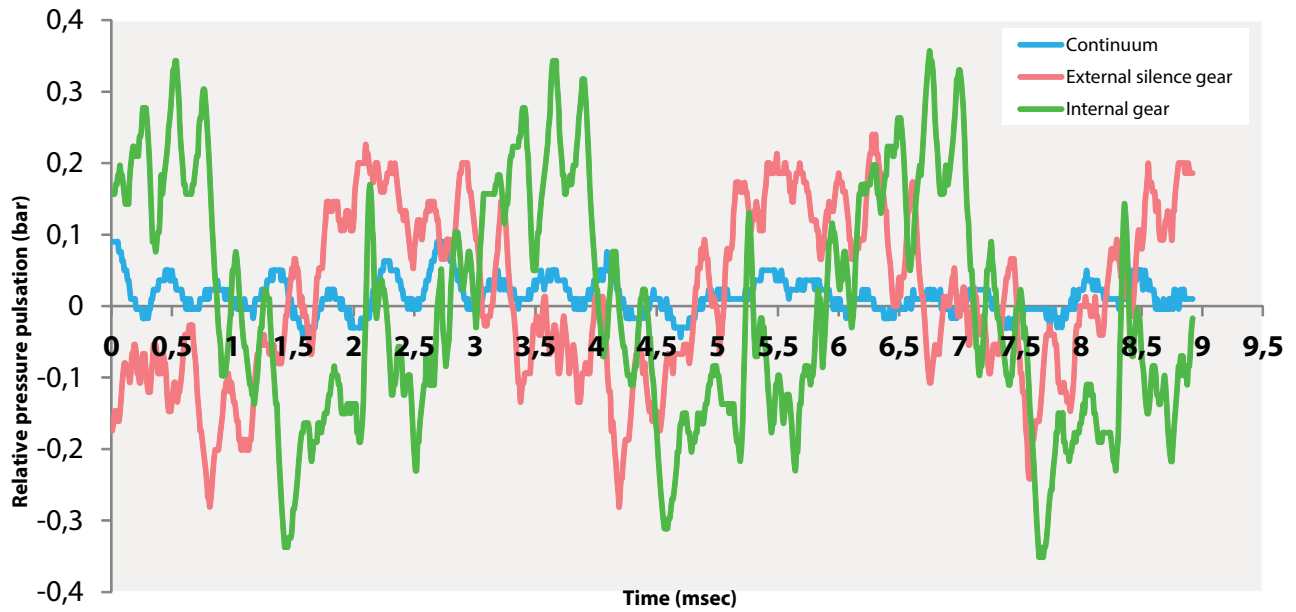

NOISE LEVEL GRAPH / GRAFICO EMISSIONI ACUSTICHE (150 bar)

GR 28

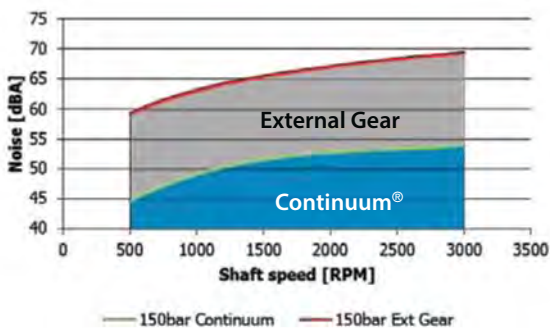

GR 33 - 38

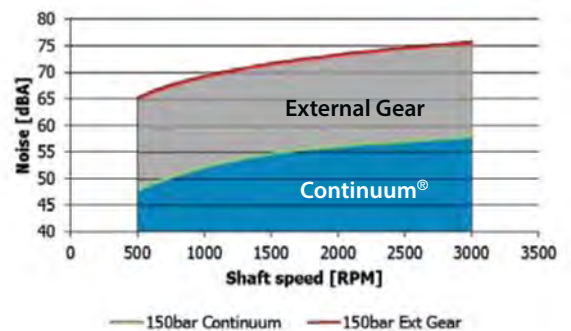

GR 47 - 55

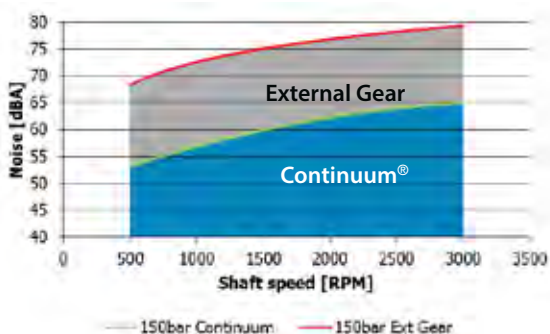

GR 72

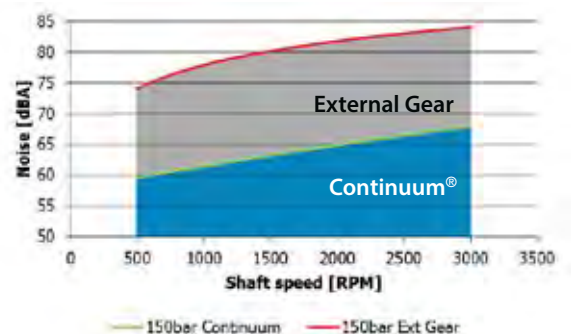

Pump displacements / Cilindrate

Group 1

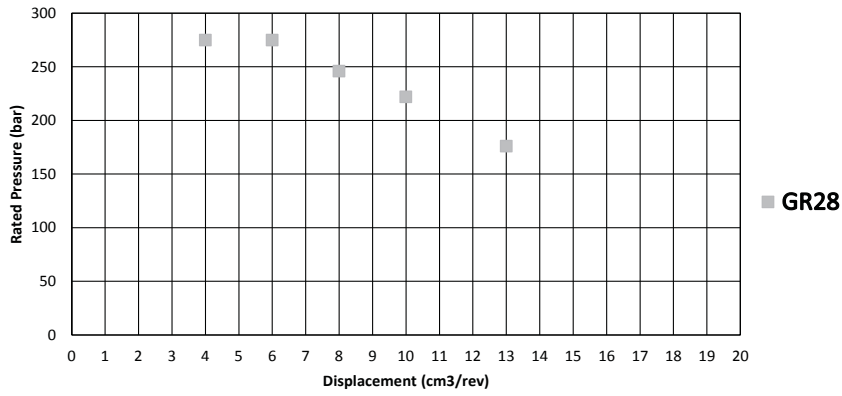

Group 2

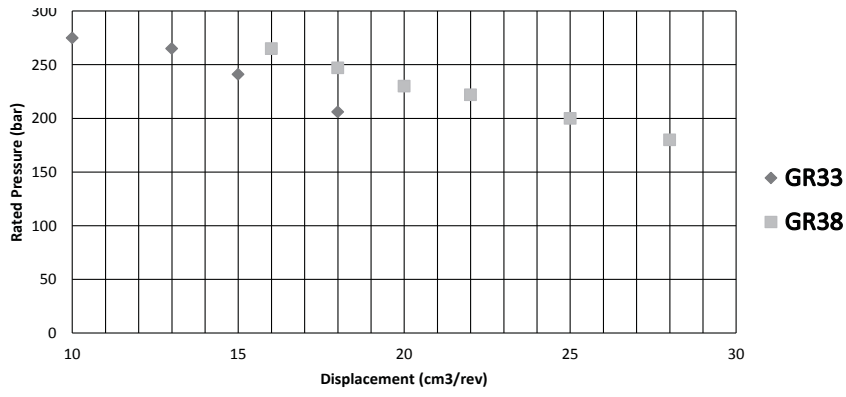

Group 3

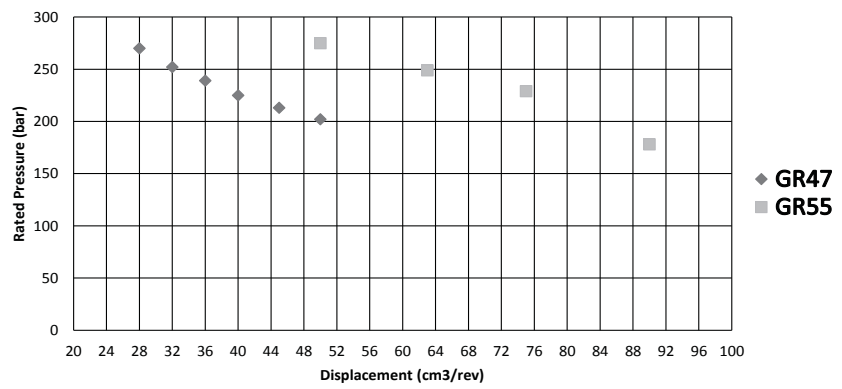

Group 4

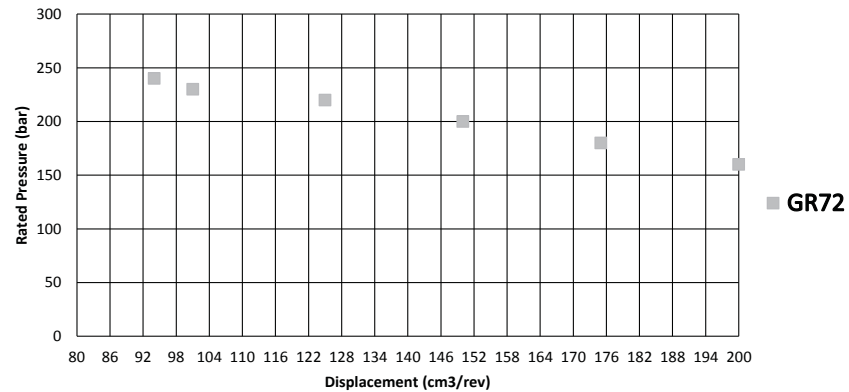

Applications / Applicazioni

INDUSTRIAL

Machine tools lubrication systems.

Lifting equipment, hydraulic systems for dock-levelers.

Hydraulic transmission systems.

Machines lubrication.

Chemical metering.

Hydraulic systems for injection moulding machines, presses, compactors and balers.

Systems for lubrication and cooling of gearboxes and bearings.

Hydraulic powerpack.

Hydro power.

Feeder system for filter circuits, cooling circuits, lubrication applications, pump transfer unit.

MOBILE

Ground-handling equipment.

Agricultural machinery.

Hydraulic systems for parking systems.

Steering units.

Torque converters & power-shift transmissions.

Street-sweeping vehicles.

Shredder systems.

Waste container level lifter.

ENVIRONMENTAL INDUSTRY

Baler and compacting of waste.

Containers.

Hooklift containers.

Back loading containers.

Front loading containers.

Liftdumper containers.

Hooklift systems.

Garbage trucks.

Mobile compactors.

Stationary compactors.

MARINE

Marine power hydraulics.

Rudder actuators (tandem system).

Propeller pitch control.

Propeller drive (power transmission from engine).

Rotary vane steering gears.

Minipowerpacks (dock operation, door control).

Yacht building industry (lifting systems: fly bridge cranes, tenderlift, elevator, walkways, automatic swimming ladders, side boarding ladders, pitch controls and operations, hydraulic davits).



Technical characteristics / Caratteristiche tecniche

SPECIAL HELICAL ROTORS – CONTINUUM® represents an innovative and revolutionary gear pump. The patented profile of the **Continuum®** rotors permits just a single point of contact between gears: this results, together with a particular screw step and inner force balancing, in the total absence of trapped and compressed oil, and leads to no noise and no pulsation.

HIGH PRESSURE – CONTINUUM® has been designed for high pressure, high speed and heavy duty.

TANDEM GROUP – CONTINUUM® can be also assembled as a double pump, connecting two pumps from different groups: from group 1 to group 4.

Technical characteristics

Models / Modelli	28 - 33 - 38 - 47 - 55 - 72 - 92* - 106*			
Flanges Flange	Group 1 – Group 2 (European, German, BKT, SAE-A) – Group 3 (European, SAE-B) – Group 4 (SAE-D) <i>Gruppo 1 – Gruppo 2 (Europeo, Tedesco, BKT, SAE-A) – Gruppo 3 (Europeo, SAE-B) – Gruppo 4 (SAE-D)</i>			
Connections Conessioni	BSPP (GAS) – SAE 3000/6000 PSI – FL 4 HOLES M6 SU Ø40 DN20 (mentioned connections depend on model) <i>BSPP (GAS) – SAE 3000/6000 PSI – FL 4 HOLES M6 SU Ø40 DN20 (in base al modello)</i>			
Installation position Posizione di installazione	External and/or under oil <i>Esterna e/o immersa</i>			
Shaft rotation Rotazione	Clockwise (please contact Settima for counter clockwise) <i>Destra (contattare Settima per sinistra)</i>			
Shaft speed Velocità di rotazione	From 150 to 6.500 rpm (for usage below 1.000 rpm or over 1.800 rpm please contact Settima) <i>Da 150 a 6.500 rpm (per utilizzi a giri inferiori a 1.000 rpm o superiori a 1.800 rpm contattare Settima)</i>			
Flows Portate	From 4 up to 220 cm ³ – from 6L/min up to 330L/min (at 1.500 rpm) <i>Da 4 fino a 220 cm³ – da 6L/min fino a 330L/min (a 1.500 rpm)</i>			
Operating pressure Pressione operativa	Max. Continuous: 275 bar	Depending on models	Max. Continuo: 275 bar	<i>In base al modello</i>
	Max. Cycle ON/OFF: 280 bar	Depending on models	Max. Ciclo ON/OFF: 280 bar	<i>In base al modello</i>
	Max. Peak: 300 bar	Depending on models	Max. Picco: 300 bar	<i>In base al modello</i>
Inlet pressure Pressione di aspirazione	0.8 – 3 bar (depends on models) <i>0,8 – 3 bar (in base al modello)</i>			
Fluids Fluidi	- Mineral oil - Synthetic oil		- <i>Olio minerale</i> - <i>Olio sintetico</i>	
Viscosity Viscosità	Possible: from 5 up to 800 cSt** Recommended: from 32 up to 150 cSt Starting condition: up to 3.000 cSt**		<i>Consentita: da 5 fino a 800 cSt**</i> <i>Raccomandata: da 32 fino a 150 cSt</i> <i>Condizioni di avviamento: fino a 3.000 cSt**</i>	
Environmental temperature Temperatura ambiente	From -15°C up to +60°C <i>Da -15°C a +60°C</i>			
Oil temperature Temperatura olio	From -15°C up to +80°C*** <i>Da -15°C a +80°C***</i>			
Contamination level Livello di contaminazione	Up to 8 NAS (18/17/14 ISO4406) (for heavy duty operations over 150 bar, over 4 working hours/day, 100 cycle/day oil ISO 46) <i>Fino a 8 NAS (18/17/14 ISO4406) (per lavoro ad alto sforzo oltre 150 bar, oltre 4 ore lavorative/giorno, 100 cicli/giorno olio ISO 46)</i>			
Filtration Filtrazione	From 25 to 10 µm (for heavy duty operations over 150 bar, over 4 working hours/day, 100 cycle/day oil ISO 46) <i>Da 25 a 10 µm (per lavoro ad alto sforzo oltre 150 bar, oltre 4 ore lavorative/giorno, 100 cicli/giorno olio ISO 46)</i>			
Seals Guarnizioni	NBR, FKM (others on request) <i>NBR, FKM (altri a richiesta)</i>			
Acoustic emissions Emissioni acustiche	From 52 up to 63 db(A) at 2.950 rpm <i>Da 52 fino a 63 db(A) at 2.950 rpm</i>			
Flanges material Materiale delle flange	Cast iron <i>Ghisa</i>			
Pump body / Corpo	Extruded aluminium alloy / <i>Alluminio estruso</i>			
Screws / Viti	Hardened steel / <i>Acciaio temprato</i>			

* Model GR92 and GR106 will be available soon. I modelli GR92 e GR106 saranno disponibili a breve.

** Please for more information about possible and starting conditions of viscosity contact Settima. Contattare Settima per maggiori informazioni sui livelli di viscosità possibili e quelli delle condizioni di inizio lavoro.

*** For higher temperature than 50°C, please, contact Settima.

Per temperature superiori a 50° C, contattare Settima.

System requirements / Requisiti del sistema

Inlet pressure

The inlet vacuum must be controlled within the prescribed range in order to achieve the expected pump life and performance. The system design must meet inlet pressure requirements during all modes of operation.

Peak pressure is the highest intermittent pressure allowed. The reaction time of the pressure relief valve determines the duration of operation at pressure above the rated value. The maximum time interval is 100 ms. The illustration to the right shows peak pressure in relation to rated pressure and reaction time (100 ms maximum).

Rated pressure is the average, regularly occurring, operating pressure that does not compromise the product's life and performance.

System pressure is the pressure differential between the outlet and inlet ports. System pressure must remain at, or below, the rated pressure during normal operation to achieve expected life.

Max. continuous vacuum	bar abs. [in. Hg]	0.8 [23.6]
Max. intermittent vacuum		0.6 [17.7]
Max. pressure		3.0 [88.5]

Time versus pressure

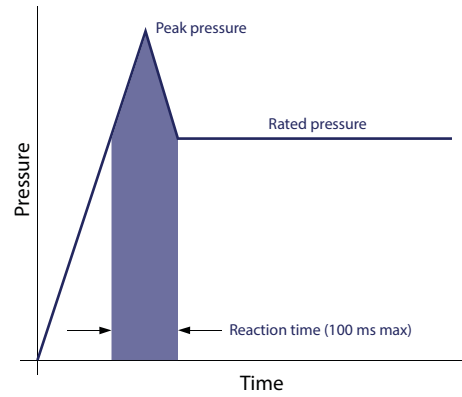

Hydraulic fluids

Ratings and data for Continuum® pumps are valid for operation with premium hydraulic fluids containing oxidation, rust, and foam inhibitors. These fluids must possess good thermal and hydrolytic stability to prevent wear, erosion, and corrosion of internal components. They include:

- Hydraulic fluids following DIN 51524, part 2 (HLP) and part 3 (HVLP) specifications
- API CD engine oils conforming to SAE J183
- M2C33F or G automatic transmission fluids
- Certain agricultural tractor fluids

Use only clean fluid in the pump and hydraulic circuit. Never mix hydraulic fluids.

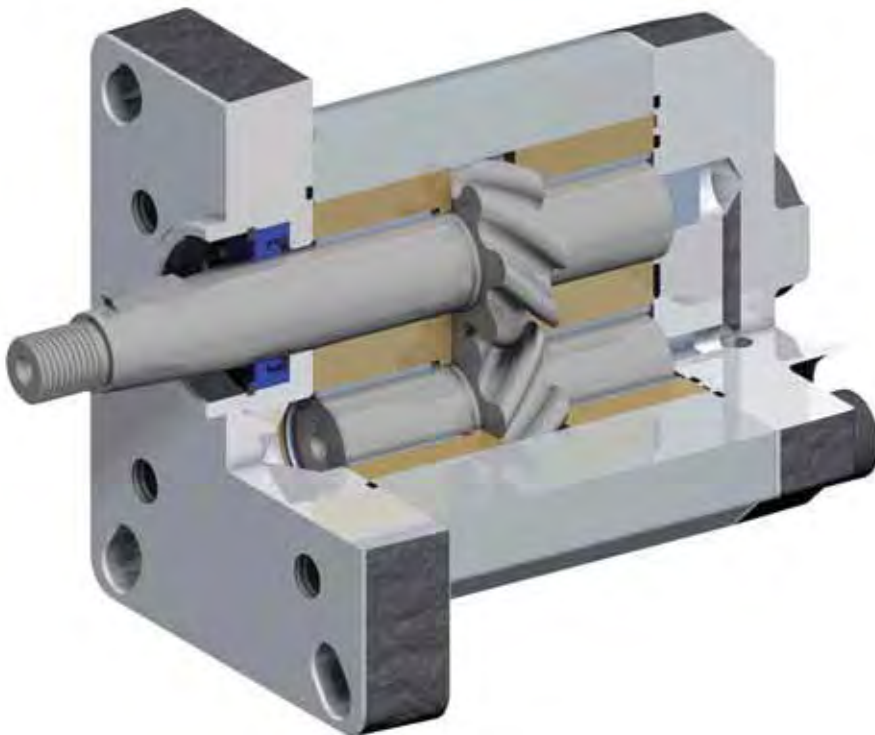

Temperature and viscosity

Temperature and viscosity requirements must be concurrently satisfied. Use petroleum / mineral-based fluids.

High temperature limits apply at the inlet port to the pump. The pump should run at or below the maximum continuous temperature. The peak temperature is based on material properties. Don't exceed it.

Cold oil, generally, doesn't affect the durability of pump components. It may affect the ability of oil to flow and transmit power. For this reason, keep the temperature at 16 °C [60 °F] above the pour point of the hydraulic fluid.

Minimum (cold start) **temperature** relates to the physical properties of component materials.

Minimum viscosity occurs only during brief occasions of maximum ambient temperature and severe duty cycle operation. You will encounter maximum viscosity only at cold start. During this condition, limit speeds until the system warms up. Size heat exchangers to keep the fluid within these limits. Test regularly to verify that these temperatures and viscosity limits aren't exceeded. For maximum unit efficiency and bearing life, keep the fluid viscosity in the recommended viscosity range.

Fluid viscosity

Maximum (cold start)		3000 [13904]
Recommended range	mm ² /s [SUS]	32-150** [148-695]
Minimum		5 [23]

Temperature

Minimum (cold start)		-15 [-4]
Maximum continuous	°C [°F]	50* [122]
Peak (intermittent)		90* [176]

*For higher temperature than 50°C, please contact Settima.

**For viscosity value out of this range, please contact Settima.

Filtration

Filters

A Class 18/17/14 of ISO 4406 (or better) filter must be used.

Selecting a filter

When selecting a filter, please consider:

- Contaminant ingress rate
(determined by factors such as the number of actuators used in the system)
- Generation of contaminants in the system
- Required fluid cleanliness
- Desired maintenance interval
- Filtration requirements of other system components

Measure filter efficiency with a Beta ratio (β_x). For:

- Suction filtration, with controlled reservoir ingress, use a $\beta_{35,45} = 75$ filter
- Return or pressure filtration, use a pressure filtration with an efficiency of $\beta_{10} = 75$.

β_x ratio is a measure of filter efficiency defined by ISO 4572. It is the ratio of the number of particles greater than a given diameter (" x " in microns) upstream of the filter to the number of these particles downstream of the filter.

Fluid cleanliness level and β_x ratio

Fluid cleanliness level (per ISO 4406)	Class 18/17/14 or better
β_x ratio (suction filtration)	$\beta_{35,45} = 75$ and $\beta_{10} = 2$
β_x ratio (pressure or return filtration)	$\beta_{10} = 75$
Recommended inlet screen size	100-125 μ m [0.004-0.005 in]

The filtration requirements for each system are unique. Evaluate filtration system capacity by monitoring and testing prototypes.

Reservoir

The **reservoir** provides clean fluid, dissipates heat, removes entrained air and makes up for changes in fluid volume due to fluid expansion-contraction and flow imbalances associated with differential cylinders. A correctly sized reservoir accommodates maximum volume changes during all system operating modes. It promotes de-aeration of the fluid as it passes through, and accommodates a fluid dwell-time between 60 and 180 seconds, allowing entrained air to escape.

Hydraulic oil contains 10% of dissolved air by volume in normal conditions and the system should be design in order to avoid any over-aeration of the hydraulic fluid, to limit any air release at the inlet port.

Minimum reservoir capacity depends on the volume required to cool and hold the oil from all retracted cylinders, allowing for expansion due to temperature changes. A fluid volume of 1 to 3 times the pump output flow (per minute) is satisfactory. The minimum reservoir capacity is 125% of the fluid volume.

The suction line shall be installed above the bottom of the reservoir to take advantage of gravity separation and prevent large foreign particles from entering the line. Cover the line with a 100-125 micron screen. The pump should be below the lowest expected fluid level.

Put the return-line below the lowest expected fluid level to allow discharge into the reservoir for maximum dwell and efficient deaeration. A baffle (or baffles) between the return and suction lines promotes deaeration and reduces fluid surges.

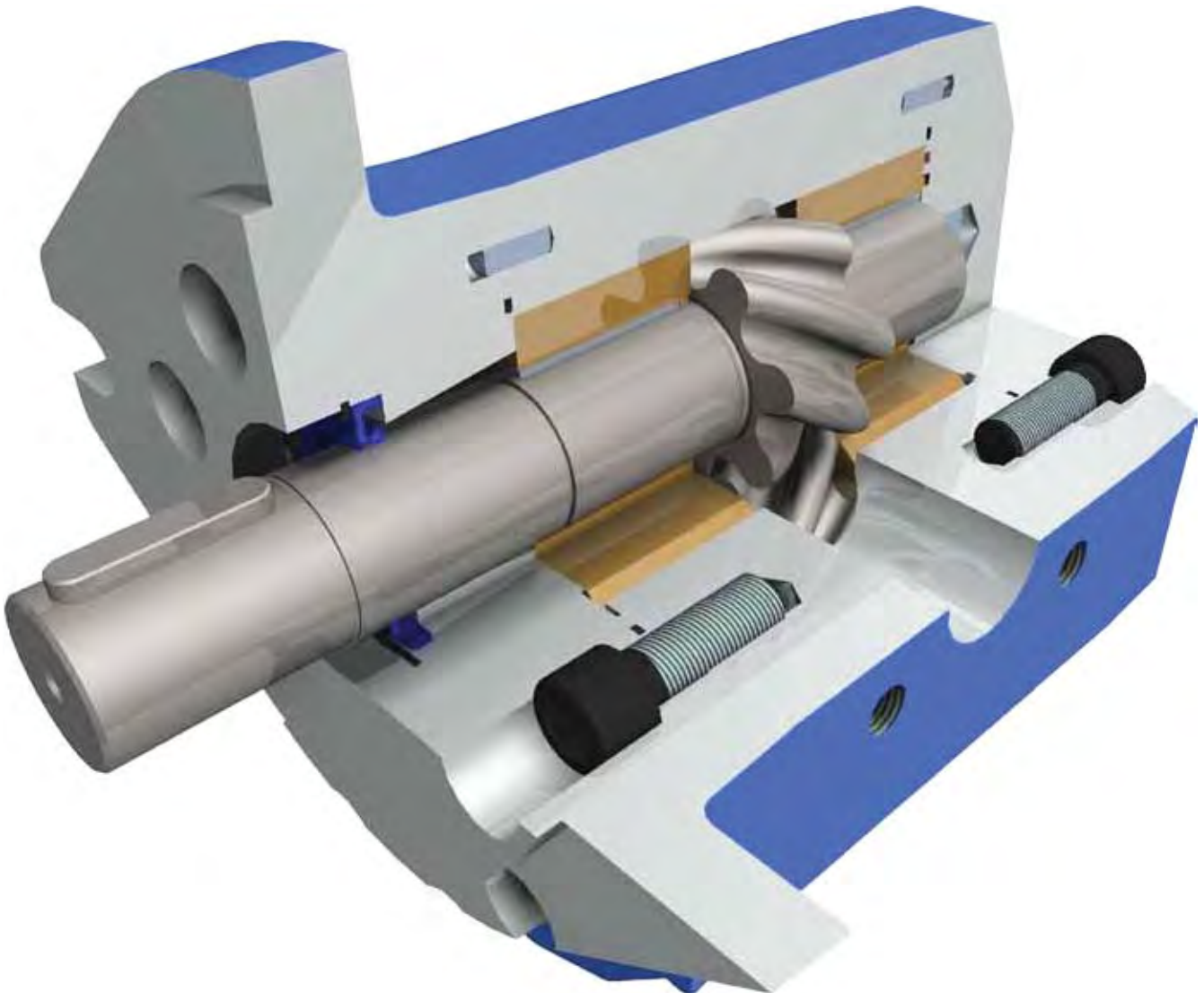

Pump drive

Shaft options for Continuum® pumps include tapered, tang, splined, or parallel shafts. They are suitable for a wide range of direct and indirect drive applications for radial and thrust loads.

Plug-in drives, acceptable only with a splined shaft, can impose severe radial loads when the mating spline is rigidly supported. Increasing spline clearance does not alleviate this condition.

Use plug-in drives if the concentricity between the mating spline and pilot diameter is within 0.1 mm [0.004 in]. Lubricate the drive by flooding it with oil. A 3-piece coupling minimizes radial or thrust shaft loads.

In order to avoid spline shaft damages it is recommended to use carburized and hardened steel couplings with 60-62 HRC surface hardness.

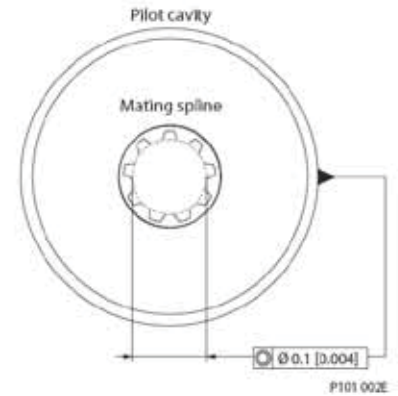

Allowable **radial shaft loads** are a function of the load position, load orientation, and operating pressure of the hydraulic pump. All external shaft loads have an effect on bearing life, and may affect pump performance.

In applications where external shaft loads can't be avoided, minimize the impact on the pump by optimizing the orientation and magnitude of the load. Use a tapered input shaft; don't use splined shafts for belt or gear drive applications. A spring-loaded belt tension-device is recommended for belt drive applications to avoid excessive tension. Avoid thrust loads in either direction. Contact Settima if continuously applied external radial or thrust loads occur.

Pump life

Pump life is a function of speed, system pressure, and other system parameters (such as fluid quality and cleanliness).

All Continuum® pumps use hydrodynamic journal bearings that have an oil film maintained between the gear/shaft and bearing surfaces at all times. If the oil film is sufficiently sustained through proper system maintenance and operating within recommended limits, long life can be expected.

B10 life expectancy number is generally associated with rolling element bearings. It does not exist for hydrodynamic bearings.

High pressure, resulting from high loads, impacts pump life. When submitting an application for review, provide machine duty cycle data that includes percentages of time at various loads and speeds. We strongly recommend a prototype testing program to verify operating parameters and their impact on life expectancy before finalizing any system design.

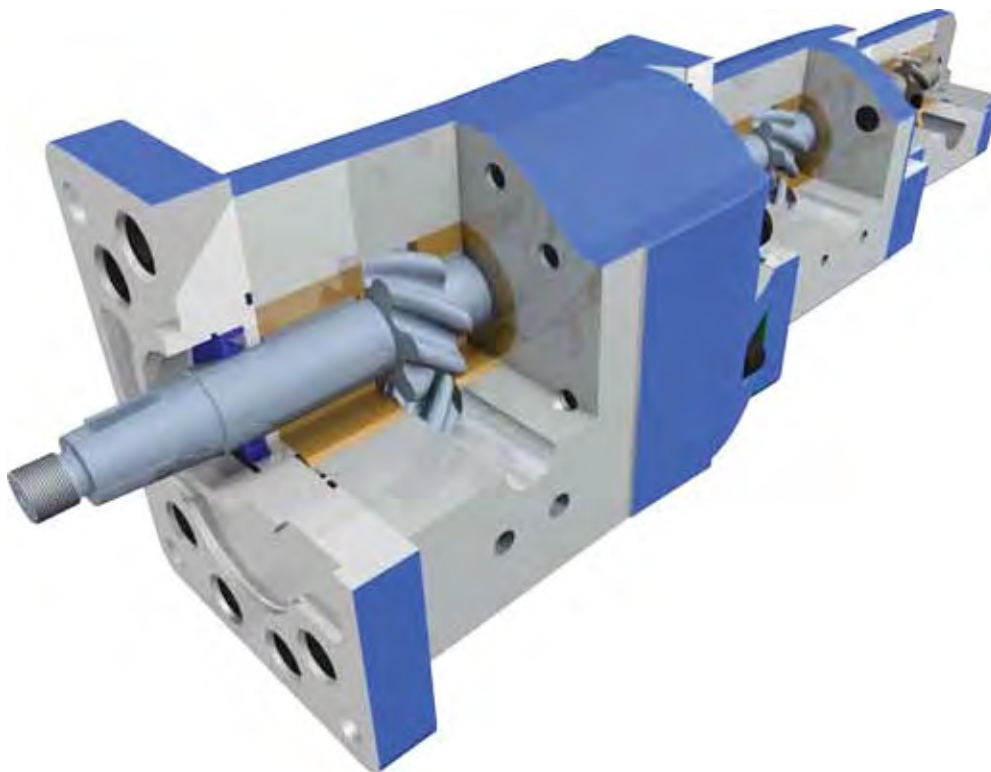

Pump drive data form

Fill out this page and send the complete form to your Settima representative for an assistance in applying pumps with belt or gear drive. This illustration shows a pump with counterclockwise orientation:

Optimal radial load position

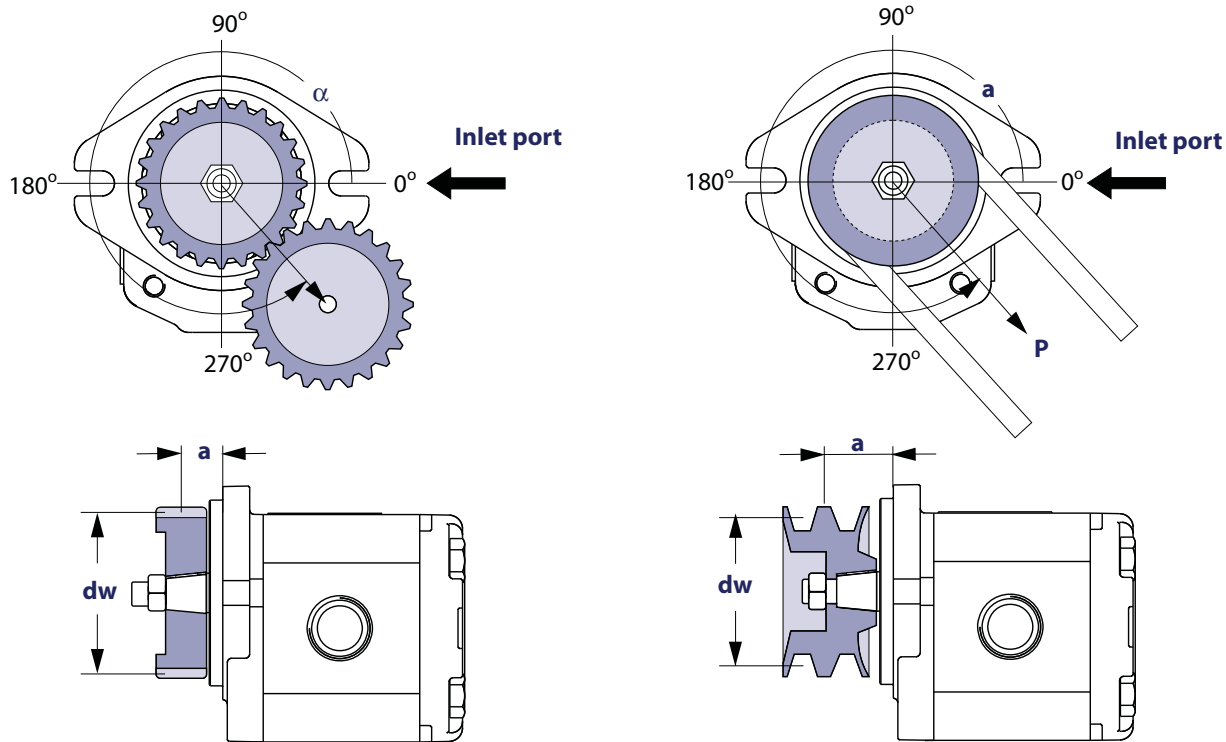

Application data

Item	Value	Unit
Pump displacement		cm ³ /rev [in ³ /rev]
Rated system pressure		<input type="checkbox"/> bar <input type="checkbox"/> psi
Relief valve setting		<input type="checkbox"/> left <input type="checkbox"/> right
Pump shaft rotation		<input type="checkbox"/> left <input type="checkbox"/> right
Pump minimum speed		min ⁻¹ (rpm)
Pump maximum speed		
Drive gear helix angle (gear drive only)		degree
Belt type (gear drive only)		<input type="checkbox"/> V <input type="checkbox"/> notch
Belt tension (gear drive only)	P	<input type="checkbox"/> N <input type="checkbox"/> lbf
Angular orientation of gear or belt to inlet port	α	degree
Pitch diameter of gear or pulley	d_w	
Distance from flange to center of gear or pulley	a	<input type="checkbox"/> mm <input type="checkbox"/> in

Product description / Descrizione prodotto

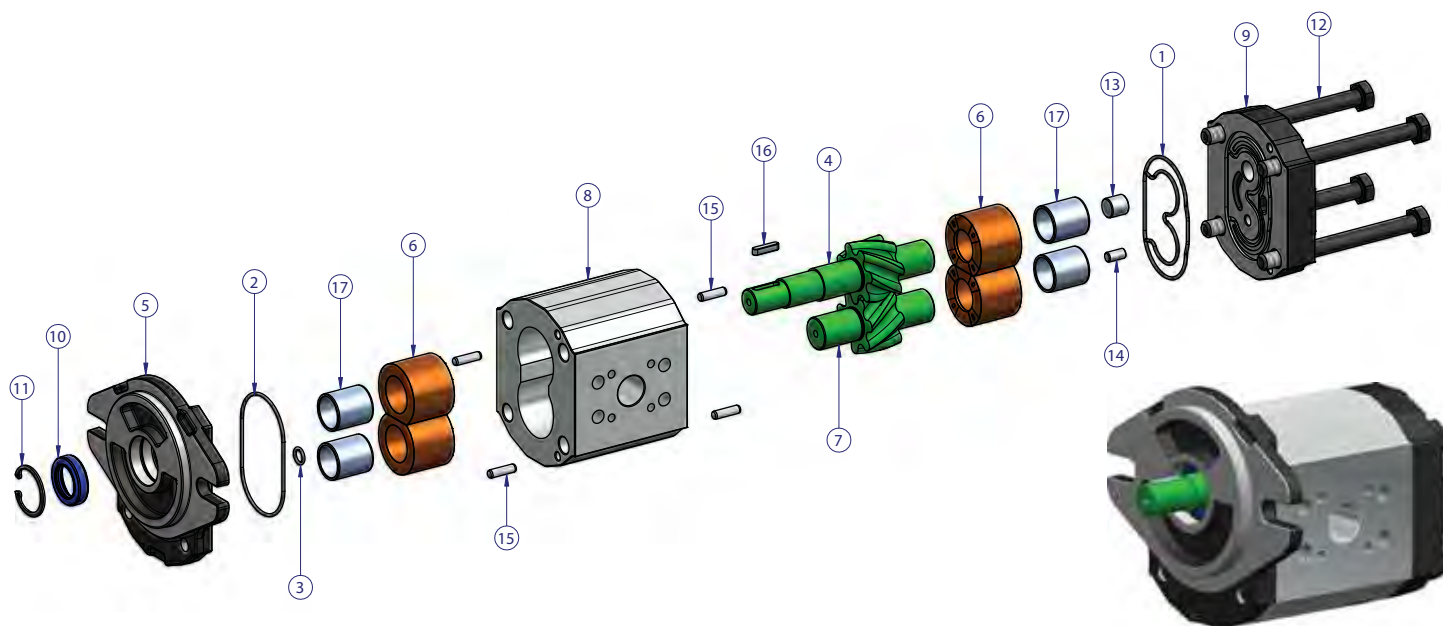



N°	DESCRIPTION/DESCRIZIONE	MATERIAL / MATERIALE
1	O-ring seal / O-ring	NBR
2	O-ring seal / O-ring	NBR
3	O-ring seal / O-ring	NBR
4	Driving Continuum® rotor / Rotore guida Continuum®	Hardened steel / Acciaio temprato
5	Motor flange / Flangia motore	Cast iron / Ghisa
6	Ring for bush / Anello porta boccia	Bronze / Bronzo
7	Driven Continuum® rotor / Rotore guidato Continuum®	Hardened steel / Acciaio temprato
8	Body / Corpo	Extruded aluminum alloy / Alluminio estruso
9	Cover flange / Flangia	Cast iron / Ghisa
10	Seal / Anello di tenuta	NBR
11	Seeger / Seeger	Steel / Acciaio
12	Screws / Viti di fissaggio	Steel / Acciaio
13	Piston / Pistone	Steel / Acciaio
14	Piston / Pistone	Steel / Acciaio
15	Centring Keys / Spine di centraggio	Steel / Acciaio
17	Bushings / Bronzine	Steel with PTFE coating / Acciaio con rivestimento PTFE

Standard type and options

	STANDARD	OPTIONS
Pump Body	Alluminium	Cast iron
Seal kit	NBR	FKM

Single pump / Pompa singola

Type <i>Tipo</i>	Class <i>Classe</i>	Displacement <i>Cilindrata</i>	Flange & shaft <i>Flangia & albero</i>	Ports <i>Porte</i>	Shaft seal <i>Guarnizione albero</i>	Rotation <i>Rotazione</i>
GR28	2V	004-006-008-010-013	F1AC3-F1PAC2-F1KAG54-F1LAGL54-FSAEAAAC-F1KAGL54	G-U	Standard NBR (none) Optional FKM V	Standard DX (none)  Optional SX* 
GR33	2V	010-013-015-018	F2AC4-F2BK7AG-FSAEAAAC-FSAEAAT9	G-Q-M-U		
GR38	2V	016-018-020-022-025-028	F2AC4-F2BK7AG-FSAEAAAC-FSAEAAT11-FSAEAAT9	G-Q-M-U		
GR47	2V	028-032-036-040-045-050	F3AC9-FSAEBAC-FSAEBAT13	O-U		
GR55	2V	050-063-075-090	FSAEBAC-FSAEBAT15	O-OE		
GR72	2V	094-101-125-150-175-200-220	FSAEDAC-FSAEDAT23	ME		

* Please Contact Settima for SX counter clockwise optional rotation.
Contattare Settima per rotazione SX opzionale.

DIRECTION OF ROTATION / SENSO DI ROTAZIONE

Continuum® pumps are available with right rotation as standard configuration and left rotation as optional configuration. Right hand rotation means that, when standing in front of the pump, with driving shaft towards to the observer, the pump is rotating clockwise (DX). The other way around with left hand rotation, counter clockwise (SX).

*Le pompe **Continuum**® sono fornite con la configurazione standard di rotazione destra. Opzionale la rotazione sinistra. Con rotazione destra (DX) si intende che, guardando la pompa frontalmente, con l'albero conduttore sporgente verso il punto di osservazione, la rotazione sarà in senso orario, con il lato mandata sulla destra e il lato aspirazione sulla sinistra della pompa. Viceversa per quanto riguarda la rotazione sinistra (SX).*

Continuum® pumps, despite the type of configuration, can rotate to the opposite side if the pressure is not higher than 10% of maximum continuous pressure (check the Technical Characteristics table).

*Le pompe **Continuum**®, qualunque configurazione di rotazione abbiano, possono ruotare in senso inverso a pressioni non superiore al 10% della massima pressione continua (verificare nella tabella delle caratteristiche tecniche).*

DX: Clockwise rotation / Rotazione destra

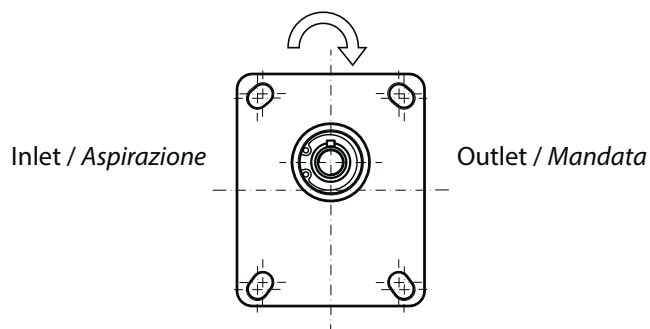

SX: Counter clockwise rotation / Rotazione sinistra

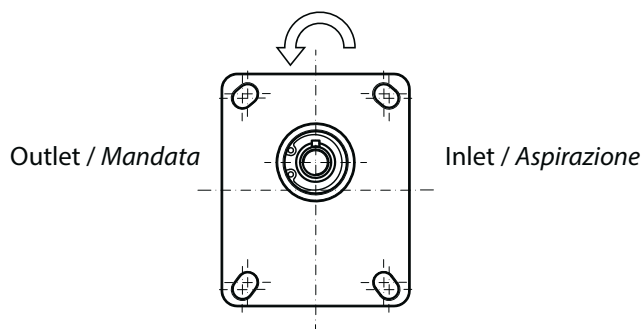

Variant codes for ordering integral relief valves*

The tables below detail the various codes for ordering integral relief valves.

R:

Code	Pump speed for RV setting
C	500 min ⁻¹ (rpm)
E	1000 min ⁻¹ (rpm)
F	1250 min ⁻¹ (rpm)
G	1500 min ⁻¹ (rpm)
K	2000 min ⁻¹ (rpm)
I	2250 min ⁻¹ (rpm)
L	2500 min ⁻¹ (rpm)
M	2800 min ⁻¹ (rpm)
N	3000 min ⁻¹ (rpm)
O	3250 min ⁻¹ (rpm)

Code	Pressure setting
18	18 bar [261 psi]
30	30 bar [435 psi]
40	40 bar [580 psi]
50	50 bar [725 psi]
60	60 bar [870 psi]
70	70 bar [1015 psi]
80	80 bar [1160 psi]
90	90 bar [1305 psi]
100	100 bar [1450 psi]
120	120 bar [1740 psi]
140	140 bar [2030 psi]
160	160 bar [2320 psi]
180	180 bar [2611 psi]
210	210 bar [3046 psi]
250	250 bar [3626 psi]

Integral relief valve schematic

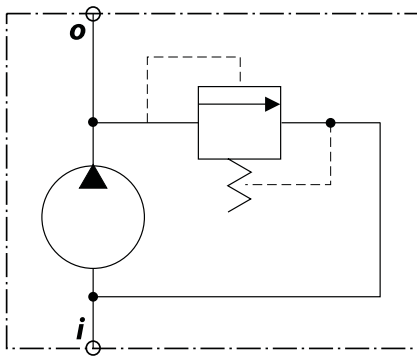

* Please, contact Settima for this option.

GR28 - Dimensional drawings / Disegni dimensionali

GR28 SHAFT AND FLANGE TYPE AND DIMENSIONS / TIPO ALBERO E FLANGE E DIMENSIONI

Group 1 pumps / Pompe gruppo 1

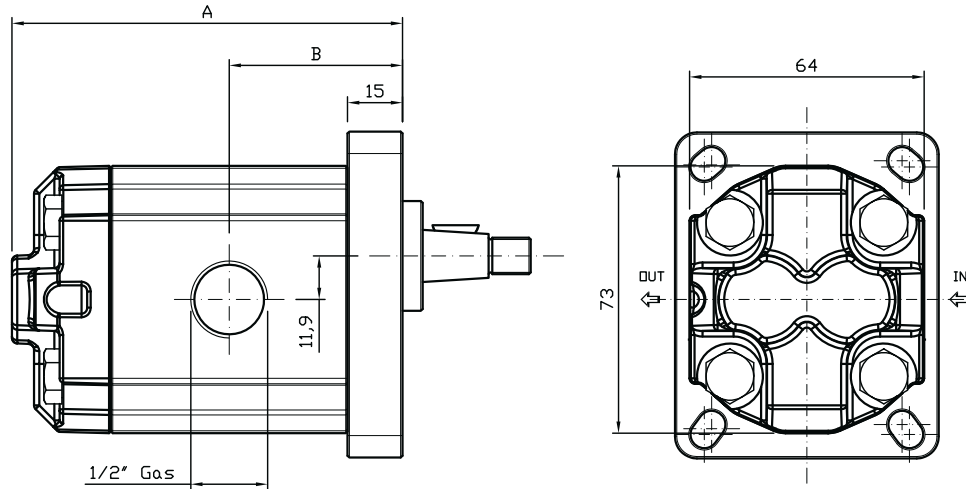

Available flanges and shafts / Flange ed alberi disponibili

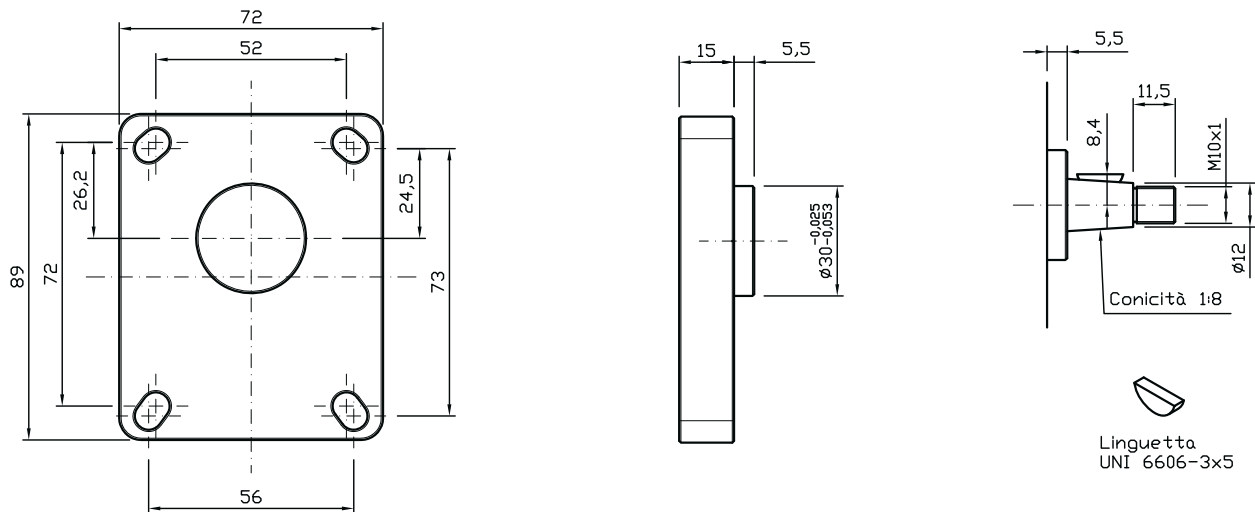

GR28 - TYPE / TIPO 1-C3

Type Tipo	CC	L/min	Dimensions A Dimensioni A	Dimensions B Dimensioni B	Continuous Pressure Pressione continua	Intermittent Pressure Pressione intermittente (*)	Peak pressure Picco pressione (*)	Noise level Livello rumore
4	4,2	6,0	101,0	44,50	275	280	300	55
6	6,4	9,2	106,5	47,25	275	280	300	55
8	8,3	12,0	111,5	49,75	246	260	280	55
10	10,2	14,7	116,5	52,25	222	250	270	55
13	12,9	18,6	123,4	55,55	176	230	250	55

Max torque / Coppia max: 100 Nm

* Intermittent: cycle 20 sec. ON & 3 sec. OFF - Peak: cycle 1 sec. ON & 3 sec OFF. Intermittente: ciclo 20 sec. ON & 3 sec. OFF - Picco: ciclo 1 sec. ON & 3 sec OFF

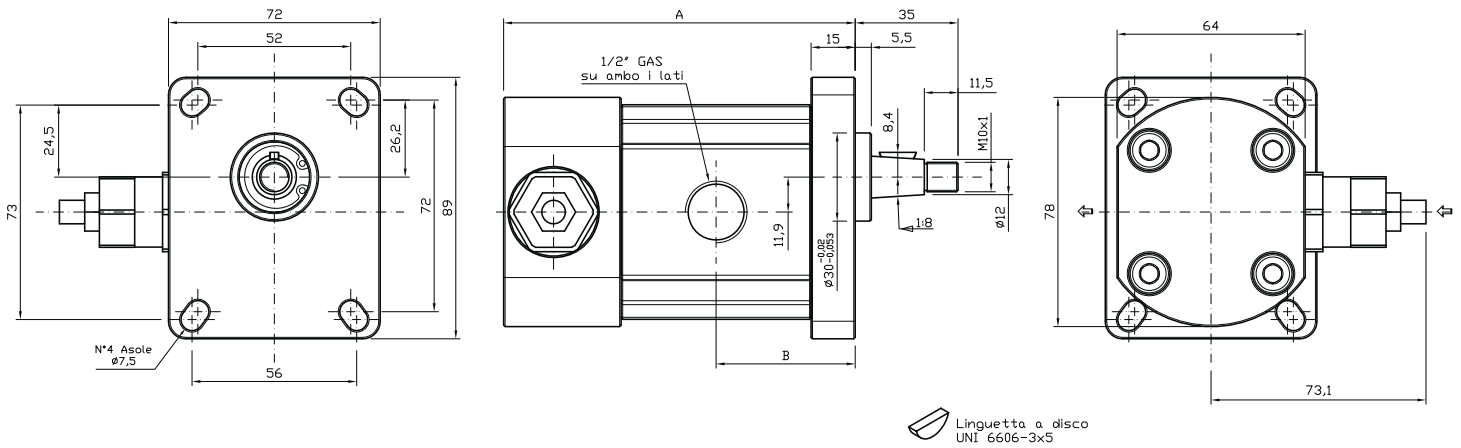

Linguetta a disco
UNI 6606-3x5

GR28 - TYPE / TIPO 1-C3 (with safety valve/con valvola di massima)

Type Tipo	CC	L/min	Dimensions A Dimensioni A	Dimensions B Dimensioni B	Continuous Pressure Pressione continua	Intermittent Pressure Pressione intermittente (*)	Peak pressure Picco pressione (*)	Noise level Livello rumore
4	4,2	6,0	114,1	44,50	275	280	300	55
6	6,4	9,2	119,5	47,25	275	280	300	55
8	8,3	12,0	124,5	49,75	246	260	280	55
10	10,2	14,7	129,5	52,25	222	250	270	55
13	12,9	18,6	136,4	55,70	176	230	250	55

Max torque / Coppia max: 100 Nm

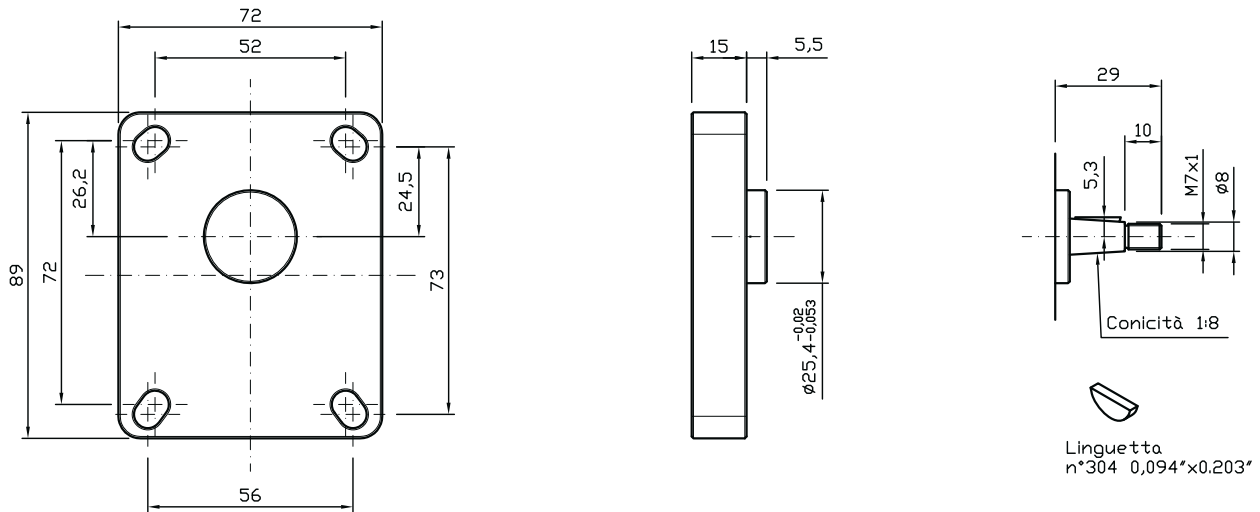

GR28 - TYPE / TIPO 1P-C2

Type Tipo	CC	L/min	Dimensions A Dimensioni A	Dimensions B Dimensioni B	Continuous Pressure Pressione continua	Intermittent Pressure Pressione intermittente (*)	Peak pressure Picco pressione (*)	Noise level Livello rumore
4	4,2	6,0	101,0	44,50	240	260	280	55
6	6,4	9,2	106,5	47,25	230	240	270	55
8	8,3	12,0	111,5	49,75	200	210	220	55
10	10,2	14,7	116,5	52,25	160	170	180	55
13	12,9	18,6	123,4	55,70	140	150	160	55

Max torque / Coppia max: 50 Nm

* Intermittent: cycle 20 sec. ON & 3 sec. OFF - Peak: cycle 1 sec. ON & 3 sec OFF. Intermittente: ciclo 20 sec. ON & 3 sec. OFF - Picco: ciclo 1 sec. ON & 3 sec OFF

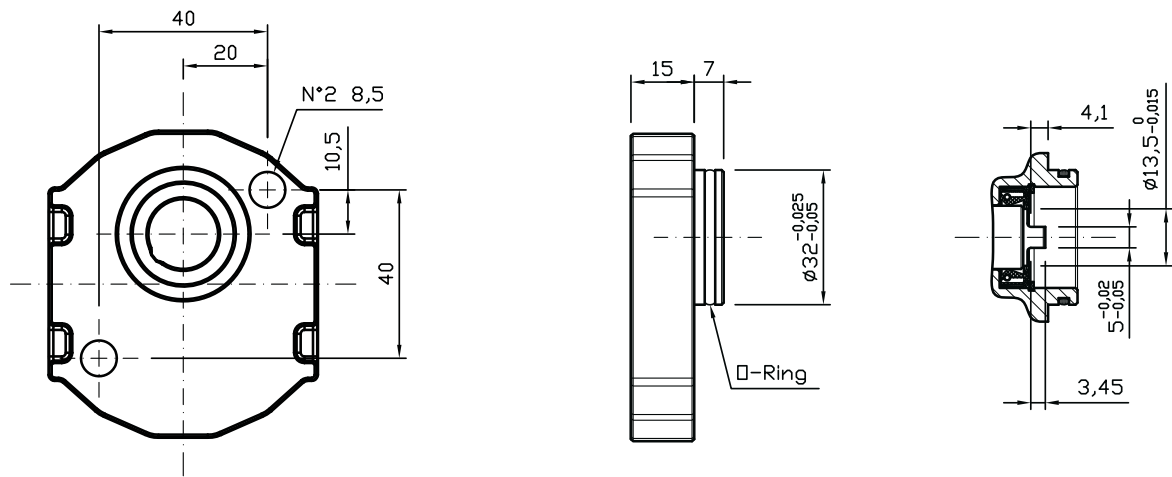

GR28 - TYPE / TIPO 1K-G54

Type Tipo	CC	L/min	Dimensions A Dimensioni A	Dimensions B Dimensioni B	Continuous Pressure Pressione continua	Intermittent Pressure Pressione intermittente (*)	Peak pressure Picco pressione (*)	Noise level Livello rumore
4	4,2	6,0	101,0	44,50	275	280	300	55
6	6,4	9,2	106,5	47,25	230	240	270	55
8	8,3	12,0	111,5	49,75	180	200	210	55
10	10,2	14,7	116,5	52,25	150	160	170	55
13	12,9	18,6	123,4	55,70	120	130	140	55

Max torque / Coppia max: 40 Nm

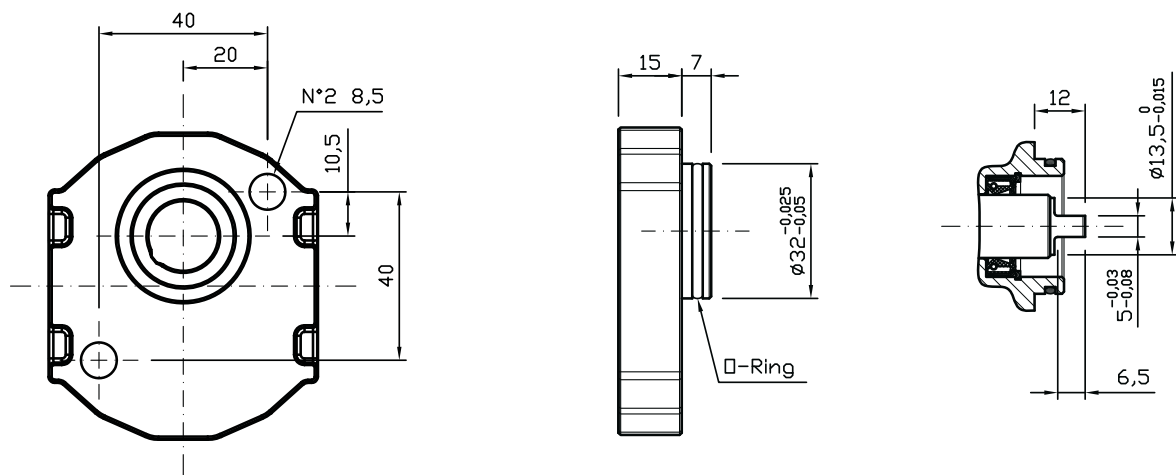

GR28 - TYPE / TIPO 1K-GL54

Type Tipo	CC	L/min	Dimensions A Dimensioni A	Dimensions B Dimensioni B	Continuous Pressure Pressione continua	Intermittent Pressure Pressione intermittente (*)	Peak pressure Picco pressione (*)	Noise level Livello rumore
4	4,2	6,0	101,0	44,50	275	280	300	55
6	6,4	9,2	106,5	47,25	260	275	290	55
8	8,3	12,0	111,5	49,75	230	240	250	55
10	10,2	14,7	116,5	52,25	180	190	200	55
13	12,9	18,6	123,4	55,70	150	160	170	55

Max torque / Coppia max: 50 Nm

* Intermittent: cycle 20 sec. ON & 3 sec. OFF - Peak: cycle 1 sec. ON & 3 sec OFF. Intermittente: ciclo 20 sec. ON & 3 sec. OFF - Picco: ciclo 1 sec. ON & 3 sec OFF

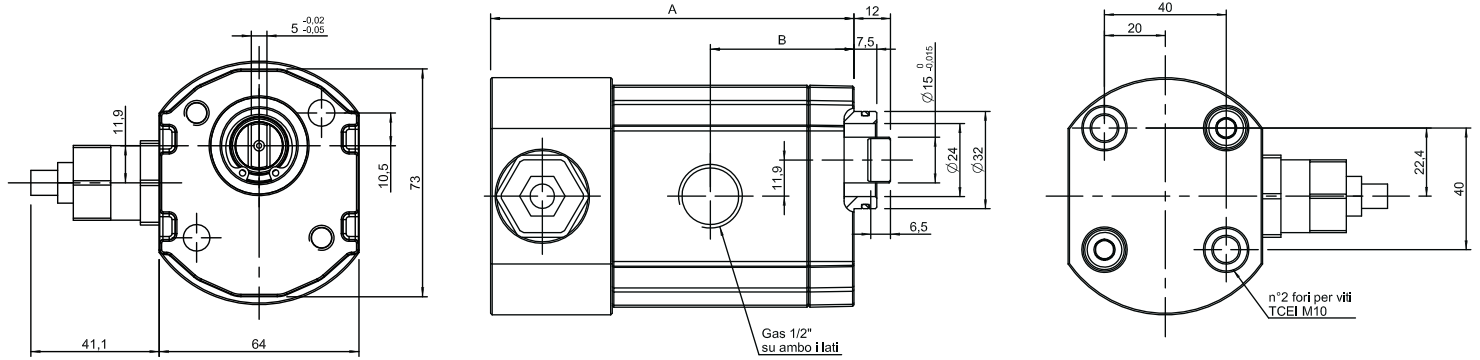

GR28 - TYPE / TIPO 1K-GL54 (with safety valve / con valvola di massima)

Type Tipo	CC	L/min	Dimensions A Dimensioni A	Dimensions B Dimensioni B	Continuous Pressure Pressione continua	Intermittent Pressure Pressione intermittente (*)	Peak pressure Picco pressione (*)	Noise level Livello rumore
4	4,2	6,0	114,0	44,5	275	280	300	55
6	6,4	9,2	119,5	47,25	260	275	290	55
8	8,3	12,0	124,5	49,75	230	240	250	55
10	10,2	14,7	129,5	52,25	180	190	200	55
13	12,9	18,6	136,4	55,70	150	160	170	55

Max torque / Coppia max: 50 Nm

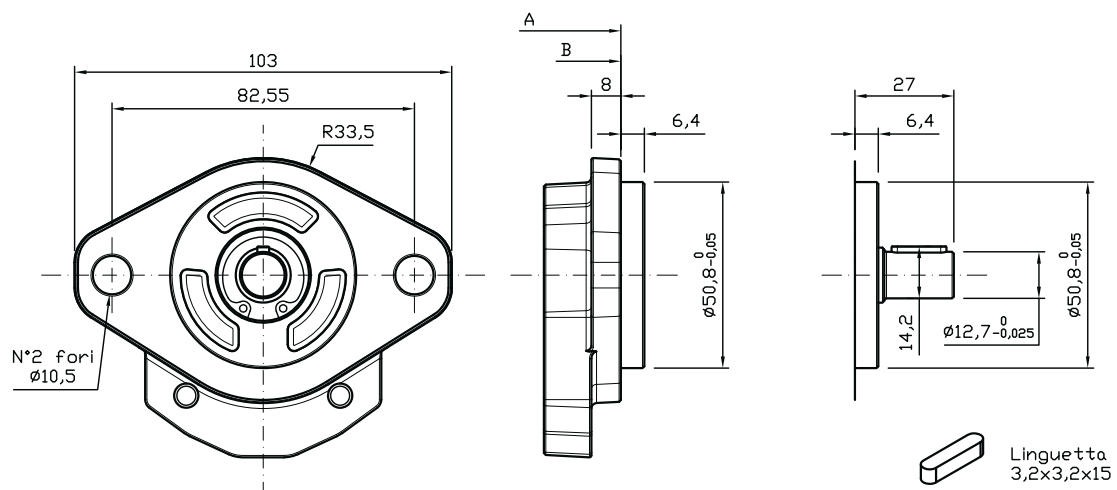

GR28 - TYPE / TIPO SAEA-A - AC

Type Tipo	CC	L/min	Dimensions A Dimensioni A	Dimensions B Dimensioni B	Continuous Pressure Pressione continua	Intermittent Pressure Pressione intermittente (*)	Peak pressure Picco pressione (*)	Noise level Livello rumore
4	4,2	6,0	107,0	50,50	234	238	255	55
6	6,4	9,2	112,5	53,25	234	238	255	55
8	8,3	12,0	117,5	55,75	209	221	238	55
10	10,2	14,7	122,5	58,25	189	213	230	55
13	12,9	18,6	129,4	61,70	170	196	213	55

Max torque / Coppia max: 60 Nm

* Intermittent: cycle 20 sec. ON & 3 sec. OFF - Peak: cycle 1 sec. ON & 3 sec OFF. Intermittente: ciclo 20 sec. ON & 3 sec. OFF - Picco: ciclo 1 sec. ON & 3 sec OFF

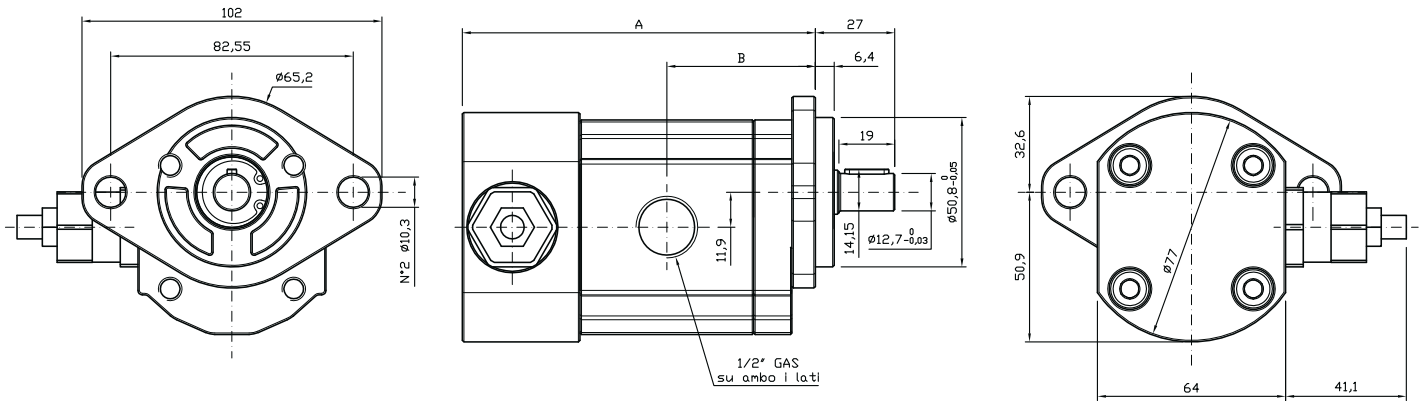

GR28 - TYPE / TIPO SAEA-A - AC (with safety valve/con valvola di massima)

Type Tipo	CC	L/min	Dimensions A Dimensioni A	Dimensions B Dimensioni B	Continuous Pressure Pressione continua	Intermittent Pressure Pressione intermittente (*)	Peak pressure Picco pressione (*)	Noise level Livello rumore
4	4,2	6,0	120,0	50,50	234	238	255	55
6	6,4	9,2	125,5	53,25	234	238	255	55
8	8,3	12,0	130,5	55,75	209	221	238	55
10	10,2	14,7	135,5	58,25	189	213	230	55
13	12,9	18,6	142,4	61,70	170	196	213	55

Max torque / Coppia max: 60 Nm

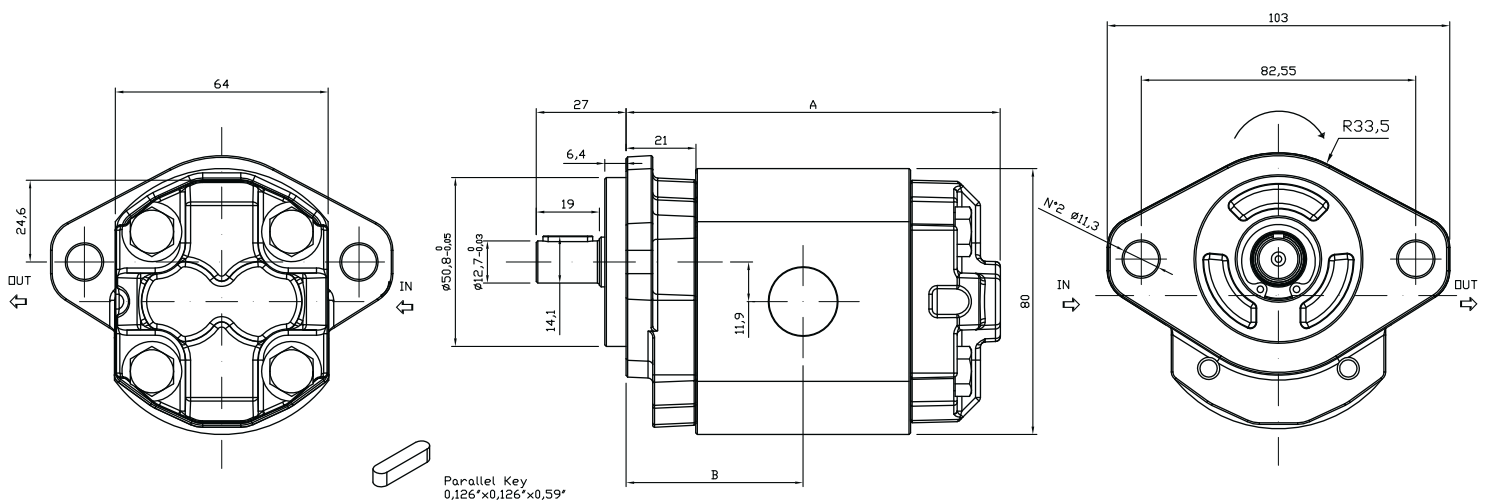

GR28 - TYPE / TIPO SAE A-A SAE O-RING PORT 3/4 14 UNF 2B

Type Tipo	CC	L/min	Dimensions A Dimensioni A	Dimensions B Dimensioni B	Continuous Pressure Pressione continua	Intermittent Pressure Pressione intermittente (*)	Peak pressure Picco pressione (*)	Noise level Livello rumore
4	4,2	6,0	107,0	50,5	234	238	255	55
6	6,4	9,2	112,5	53,25	234	238	255	55
8	8,3	12,0	117,5	55,75	209	221	238	55
10	10,2	14,7	122,5	58,25	189	213	230	55
13	12,9	18,6	129,4	61,70	170	196	213	55

Max torque / Coppia max: 60 Nm

* Intermittent: cycle 20 sec. ON & 3 sec. OFF - Peak: cycle 1 sec. ON & 3 sec OFF. Intermittente: ciclo 20 sec. ON & 3 sec. OFF - Picco: ciclo 1 sec. ON & 3 sec OFF

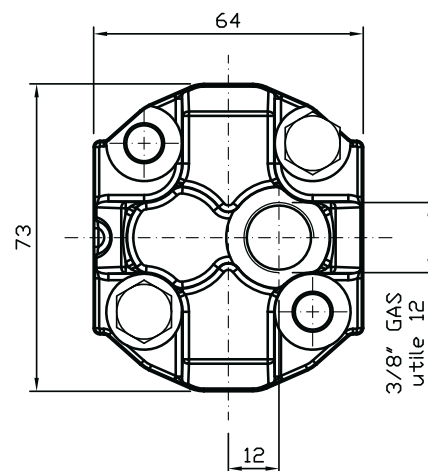
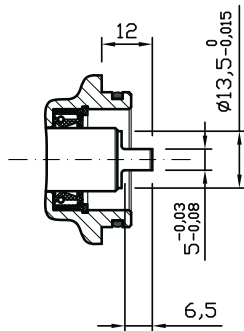
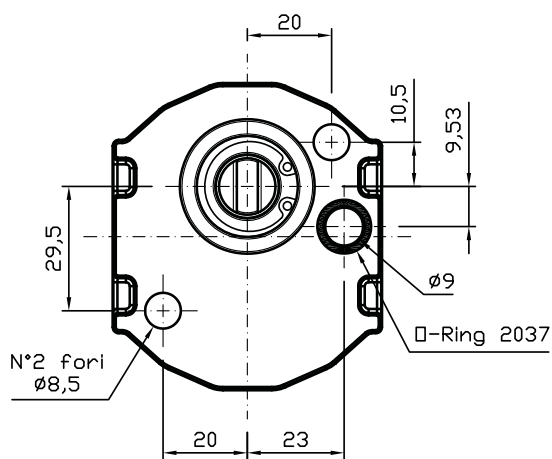

GR28 - TYPE / TIPO 1L-GL54

Type Tipo	CC	L/min	Dimensions A Dimensioni A	Continuous Pressure Pressione continua	Intermittent Pressure Pressione intermittente (*)	Peak pressure Picco pressione (*)	Noise level Livello rumore
4	4,2	6,0	101,0	275	280	300	55
6	6,4	9,2	106,5	260	275	290	55
8	8,3	12,0	111,5	230	240	250	55
10	10,2	14,7	116,5	180	190	200	55
13	12,9	18,6	123,4	150	160	170	55

Max torque / Coppia max: 50 Nm

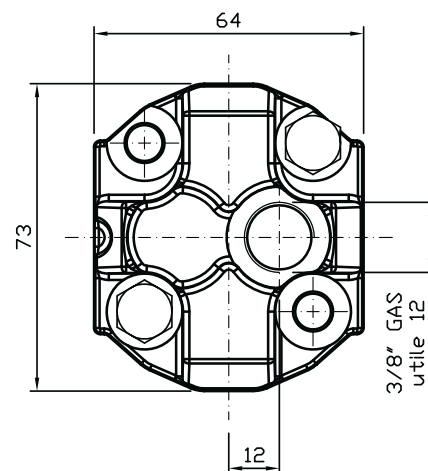
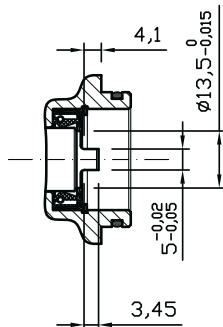
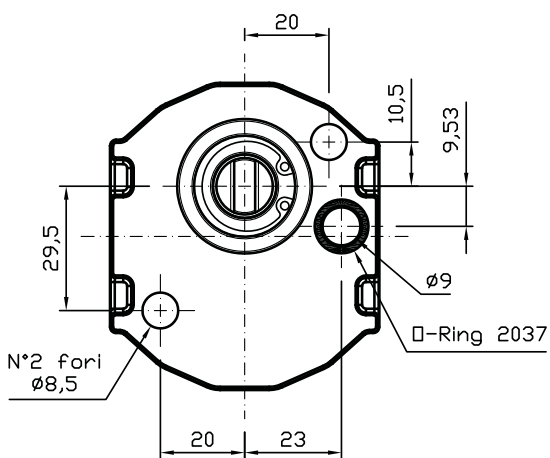

GR28 - TYPE / TIPO 1L-G54

Type Tipo	CC	L/min	Dimensions A Dimensioni A	Continuous Pressure Pressione continua	Intermittent Pressure Pressione intermittente (*)	Peak pressure Picco pressione (*)	Noise level Livello rumore
4	4,2	6,0	101,0	275	280	300	55
6	6,4	9,2	106,5	230	240	270	55
8	8,3	12,0	111,5	180	200	210	55
10	10,2	14,7	116,5	150	160	170	55
13	12,9	18,6	123,4	120	130	140	55

Max torque / Coppia max: 40 Nm

* Intermittent: cycle 20 sec. ON & 3 sec. OFF - Peak: cycle 1 sec. ON & 3 sec OFF. Intermittente: ciclo 20 sec. ON & 3 sec. OFF - Picco: ciclo 1 sec. ON & 3 sec OFF

GR33 - Dimensional drawings / Disegni dimensionali

GR33 SHAFT AND FLANGE TYPE AND DIMENSIONS / TIPO ALBERO E FLANGE E DIMENSIONI

Group 2 pumps / Pompe gruppo 2

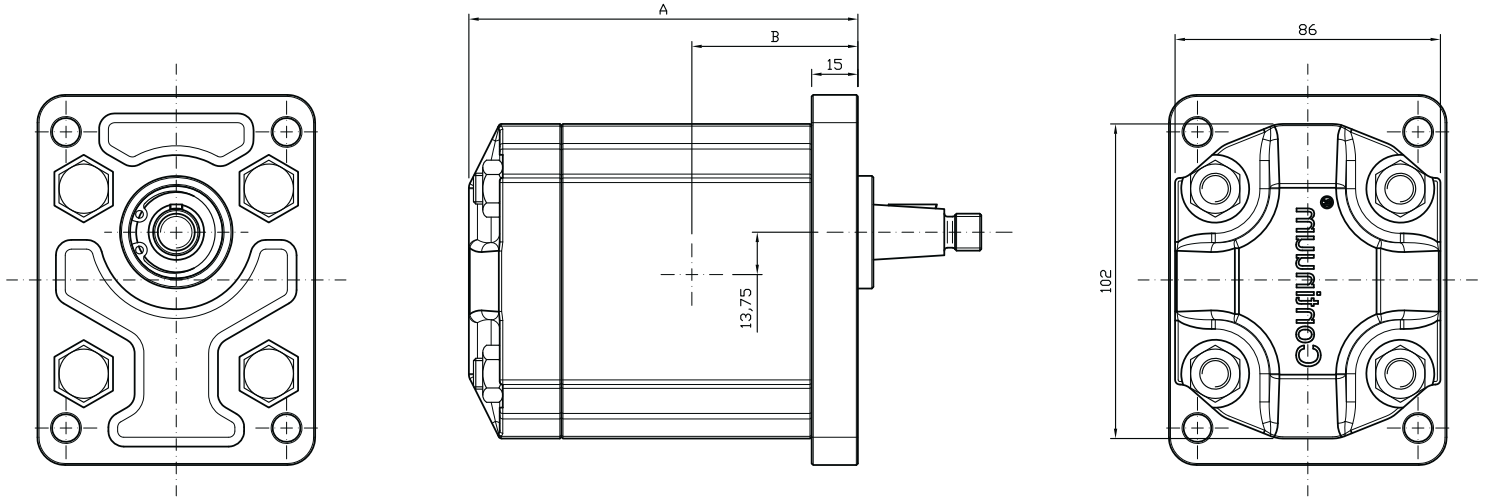

Available flanges and shafts / Flange ed alberi disponibili

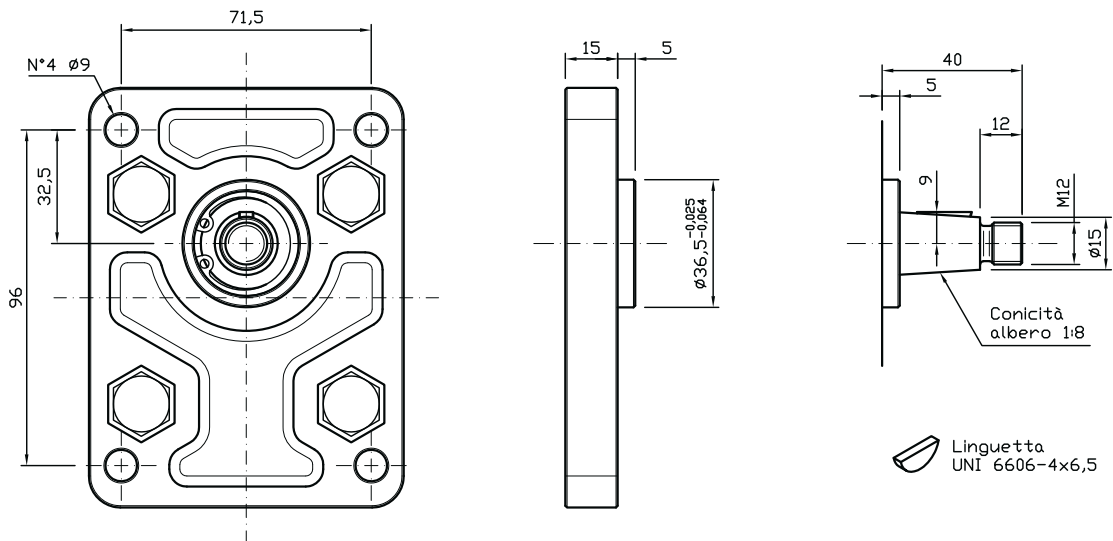

GR33 - TYPE / TIPO 2-C4

Type Tipo	CC	L/min	Dimensions A Dimensioni A	Dimensions B Dimensioni B	Continuous Pressure Pressione continua	Intermittent Pressure Pressione intermittente (*)	Peak pressure Picco pressione (*)	Noise level Livello rumore
10	10,1	14,5	122,5	53,75	275	280	300	55
13	12,6	18,1	127,4	56,20	265	270	290	55
15	15,2	21,8	132,4	58,70	241	250	270	55
18	18,2	26,1	138,2	61,60	206	250	270	55

Max torque / Coppia max: 210 Nm

* Intermittent: cycle 20 sec. ON & 3 sec. OFF - Peak: cycle 1 sec. ON & 3 sec OFF. Intermittente: ciclo 20 sec. ON & 3 sec. OFF - Picco: ciclo 1 sec. ON & 3 sec OFF

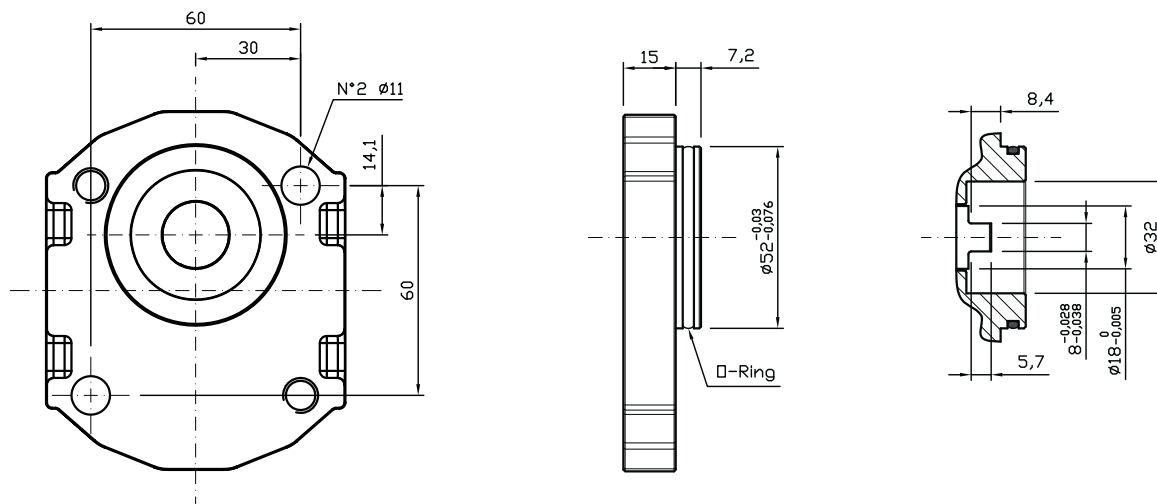

GR33 - TYPE / TIPO 2BK7-AG

Type Tipo	CC	L/min	Dimensions A Dimensioni A	Dimensions B Dimensioni B	Continuous Pressure Pressione continua	Intermittent Pressure Pressione intermittente (*)	Peak pressure Picco pressione (*)	Noise level Livello rumore
10	10,1	14,5	122,5	53,75	275	280	300	55
13	12,6	18,1	127,4	56,20	265	270	290	55
15	15,2	21,8	132,4	58,70	241	250	270	55
18	18,2	26,1	138,2	61,60	206	250	270	55

Max torque / Coppia max: 110 Nm

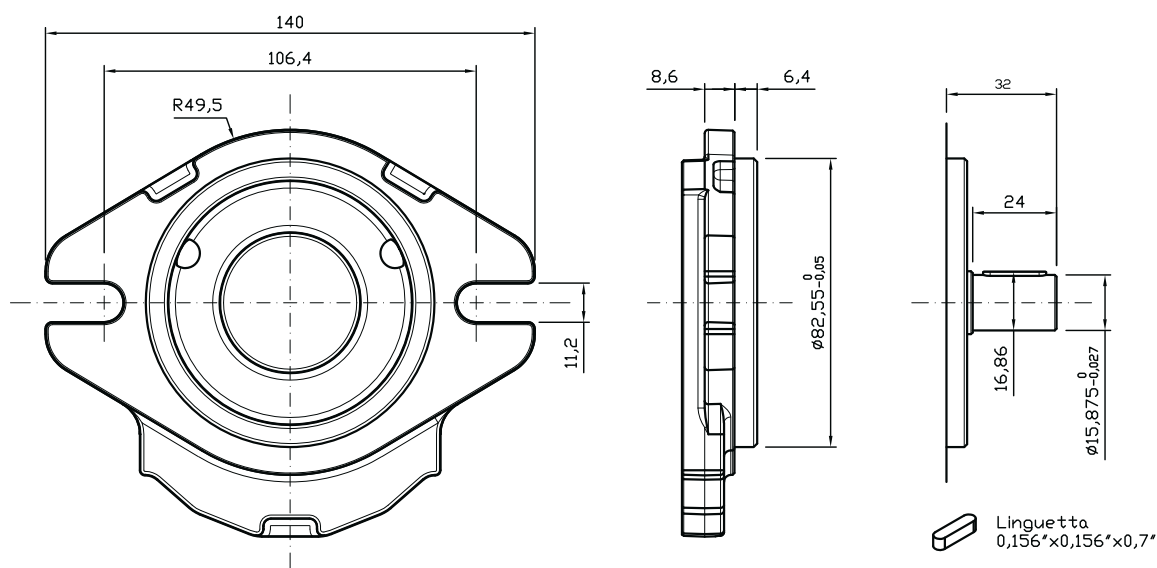

GR33 - TYPE / TIPO SAEA-AC

Type Tipo	CC	L/min	Dimensions A Dimensioni A	Dimensions B Dimensioni B	Continuous Pressure Pressione continua	Intermittent Pressure Pressione intermittente (*)	Peak pressure Picco pressione (*)	Noise level Livello rumore
10	10,1	14,5	122,5	53,75	275	280	300	55
13	12,6	18,1	127,4	56,20	265	270	290	55
15	15,2	21,8	132,4	58,70	241	250	270	55
18	18,2	26,1	138,2	61,60	206	250	270	55

Max torque / Coppia max: 140 Nm

* Intermittent: cycle 20 sec. ON & 3 sec. OFF - Peak: cycle 1 sec. ON & 3 sec OFF. Intermittente: ciclo 20 sec. ON & 3 sec. OFF - Picco: ciclo 1 sec. ON & 3 sec OFF

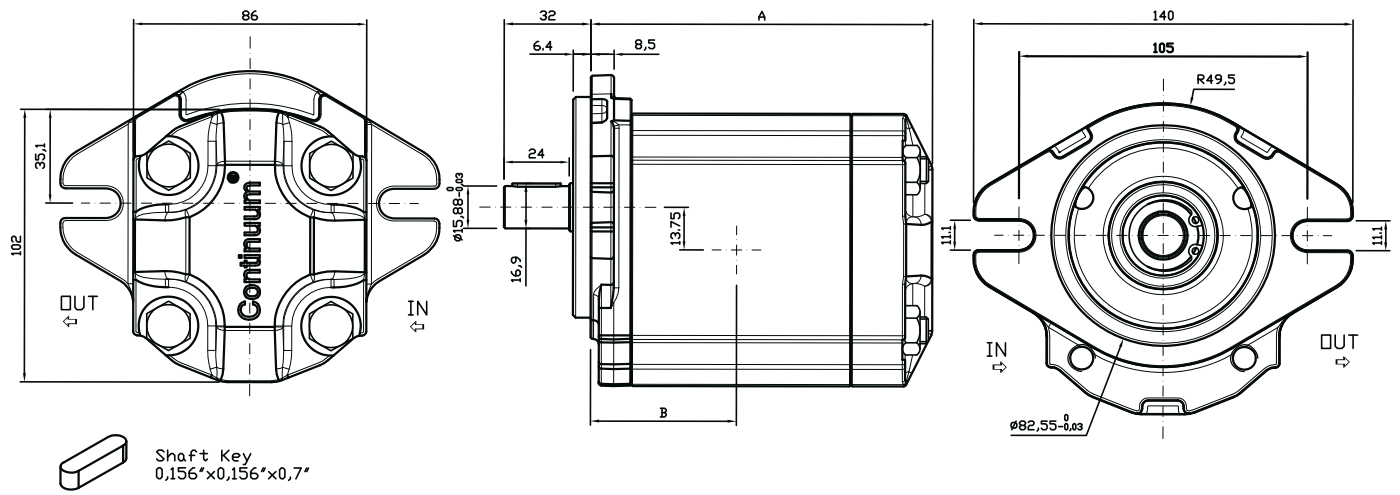

GR33 - TYPE / TIPO SAEA-AC SAE O-RING UNF

Type Tipo	CC	L/min	Dimensions A Dimensioni A	Dimensions B Dimensioni B	Continuous Pressure Pressione continua	Intermittent Pressure Pressione intermittente (*)	Peak pressure Picco pressione (*)	Noise level Livello rumore
10	10,1	14,5	122,5	53,75	275	280	300	55
13	12,6	18,1	127,4	56,20	265	270	290	55
15	15,2	21,8	132,4	58,70	241	250	270	55
18	18,2	26,1	138,2	61,60	206	250	270	55

Max torque / Coppia max: 140 Nm

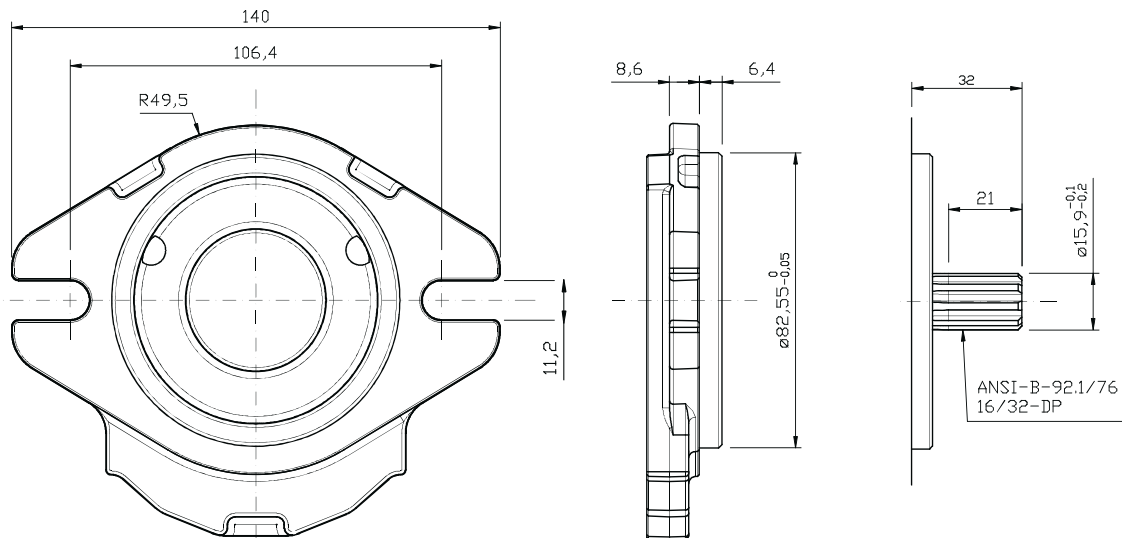

GR33 - TYPE / TIPO SAEA-T9

Type Tipo	CC	L/min	Dimensions A Dimensioni A	Dimensions B Dimensioni B	Continuous Pressure Pressione continua	Intermittent Pressure Pressione intermittente (*)	Peak pressure Picco pressione (*)	Noise level Livello rumore
10	10,1	14,5	122,5	53,75	275	280	300	55
13	12,6	18,1	127,4	56,20	265	270	290	55
15	15,2	21,8	132,4	58,70	241	250	270	55
18	18,2	26,1	138,2	61,60	206	250	270	55

Max torque / Coppia max: 190 Nm

* Intermittent: cycle 20 sec. ON & 3 sec. OFF - Peak: cycle 1 sec. ON & 3 sec OFF. Intermittente: ciclo 20 sec. ON & 3 sec. OFF - Picco: ciclo 1 sec. ON & 3 sec OFF

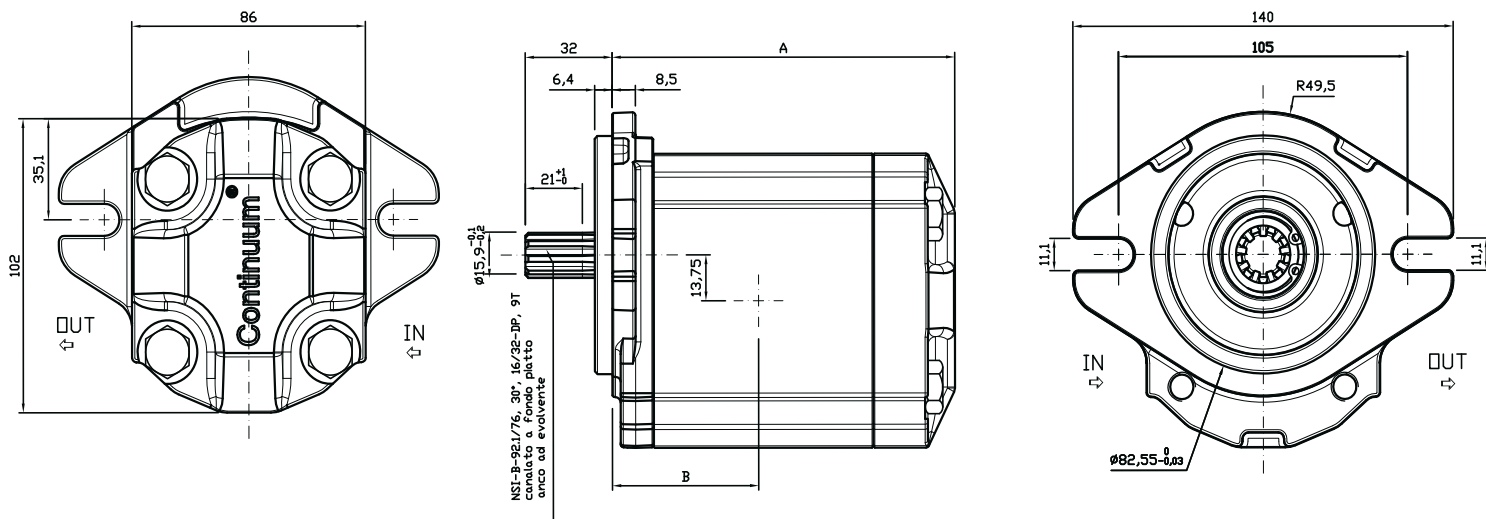

GR33 - TYPE / TIPO SAE-T9 SAE O-RING UNF

Type Tipo	CC	L/min	Dimensions A Dimensioni A	Dimensions B Dimensioni B	Continuous Pressure Pressione continua	Intermittent Pressure Pressione intermittente (*)	Peak pressure Picco pressione (*)	Noise level Livello rumore
10	10,1	14,5	122,5	53,75	275	280	300	55
13	12,6	18,1	127,4	56,20	265	270	290	55
15	15,2	21,8	132,4	58,70	241	250	270	55
18	18,2	26,1	138,2	61,60	206	250	270	55

Max torque / Coppia max: 190 Nm

* Intermittent: cycle 20 sec. ON & 3 sec. OFF - Peak: cycle 1 sec. ON & 3 sec OFF. Intermittente: ciclo 20 sec. ON & 3 sec. OFF - Picco: ciclo 1 sec. ON & 3 sec OFF

INLET OUTLET PORTS / PORTE DI ASPIRAZIONE E MANDATA (Suction / Pressure)

Type G / Tipo G

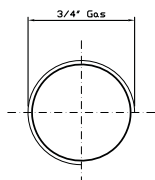

Type Q / Tipo Q

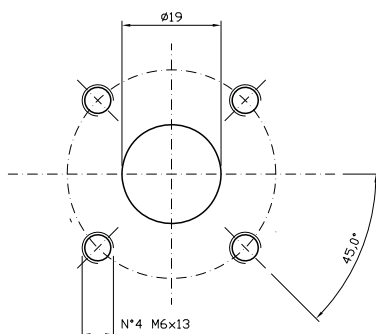

Type M / Tipo M

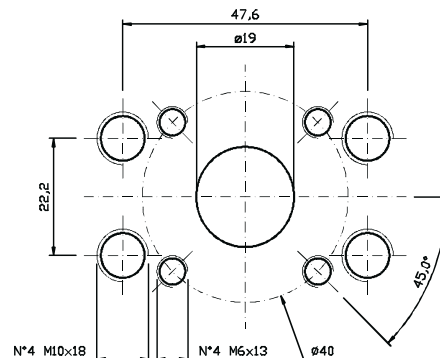

UNF INLET OUTLET PORTS / PORTE DI ASPIRAZIONE E MANDATA UNF - Type U / Tipo U

SAE O-Ring Port 12 thread
ANSI B1.1 1 1/16 UN-2B

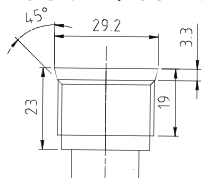

SAE O-Ring Port 16 thread
ANSI B1.1 1 5/16 12 UN-2B

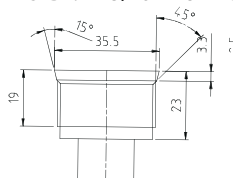

Suction

SAE O-Ring Port 10 thread
ANSI B1.1 1 7/8 14 UNF-2B

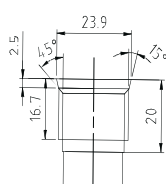

SAE O-Ring Port 12 thread
ANSI B1.1 1 1/16 12 UN-2B

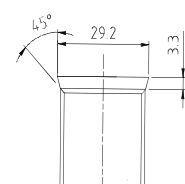

Pressure

Suction/Pressure UNF ports possible configuration
Possibili combinazioni porte di aspirazione/mandata di tipo UNF

Pump	Suction port	Pressure port
GR33 - 10 cc	SAE O-Ring port 12	SAE O-Ring port 10
GR33 - 13 cc	SAE O-Ring port 12	SAE O-Ring port 10
GR33 - 15 cc	SAE O-Ring port 12	SAE O-Ring port 10
GR33 - 18 cc	SAE O-Ring port 16	SAE O-Ring port 12

GR38 - Dimensional drawings / Disegni dimensionali

GR38 SHAFT AND FLANGE TYPE AND DIMENSIONS / TIPO ALBERO E FLANGE E DIMENSIONI

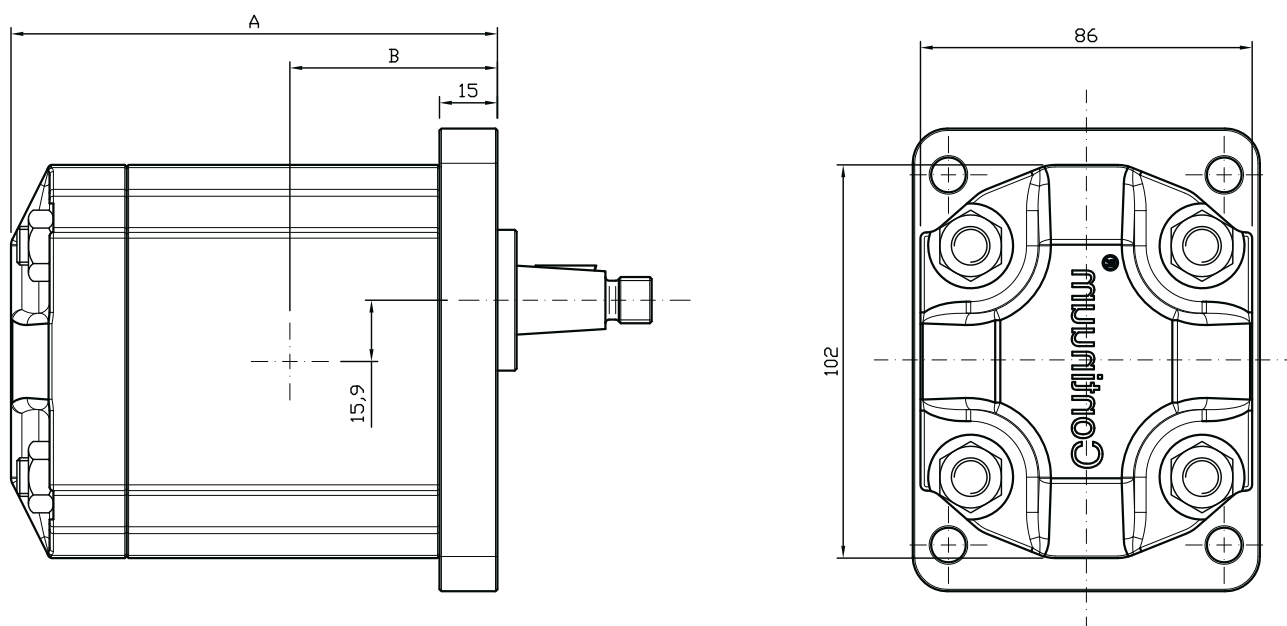

Available flanges and shafts / Flange ed alberi disponibili

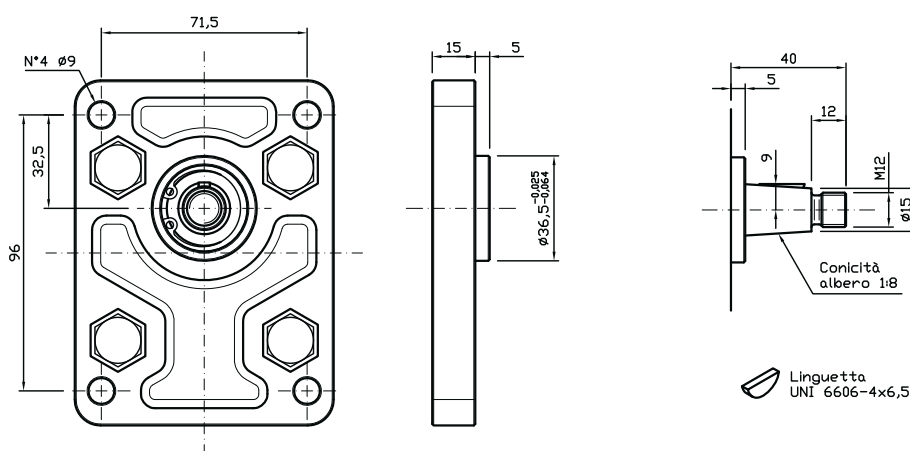

Linguetta
UNI 6606-4x6,5

GR38 - TYPE / TIPO 2-C4

Type Tipo	CC	L/min	Dimensions A Dimensioni A	Dimensions B Dimensioni B	Continuous Pressure Pressione continua	Intermittent Pressure Pressione intermittente (*)	Peak pressure Picco pressione (*)	Noise level Livello rumore
16	15,9	22,8	126,0	55,50	265	280	300	55
18	17,9	25,8	129,0	57,00	247	260	280	55
20	20,0	28,8	132,0	58,50	230	250	270	55
22	22,1	31,8	135,0	60,00	222	240	260	55
25	25,2	36,2	139,5	62,25	200	210	220	55
28	28,3	40,7	144,0	64,50	180	190	200	55

Max torque / Coppia max: 210 Nm

* Intermittent: cycle 20 sec. ON & 3 sec. OFF - Peak: cycle 1 sec. ON & 3 sec OFF. Intermittente: ciclo 20 sec. ON & 3 sec. OFF - Picco: ciclo 1 sec. ON & 3 sec OFF

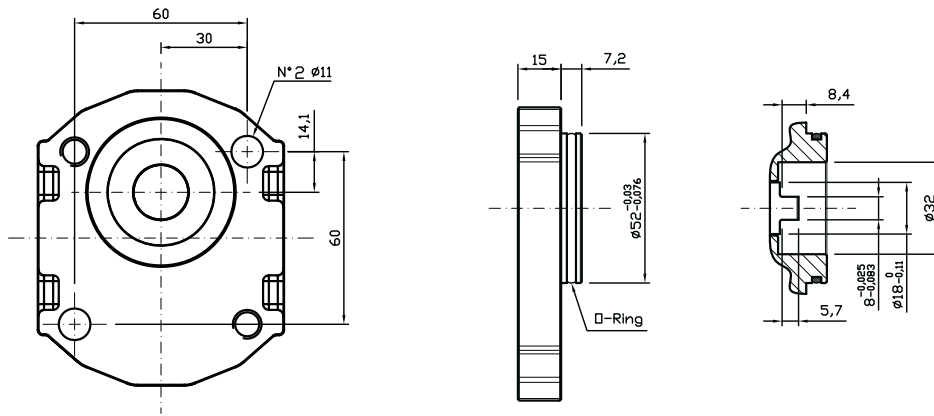

GR38 - TYPE / TIPO 2BK7-AG

Type Tipo	CC	L/min	Dimensions A Dimensioni A	Dimensions B Dimensioni B	Continuous Pressure Pressione continua	Intermittent Pressure Pressione intermittente (*)	Peak pressure Picco pressione (*)	Noise level Livello rumore
16	15,9	22,8	126,0	55,50	265	280	300	55
18	17,9	25,8	129,0	57,00	247	260	280	55
20	20,0	28,8	132,0	58,50	230	250	260	55
22	22,1	31,8	135,0	60,00	210	230	240	55
25	25,2	36,2	139,5	62,25	200	210	220	55
28	28,3	40,7	144,0	64,50	180	190	200	55

Max torque / Coppia max: 110 Nm

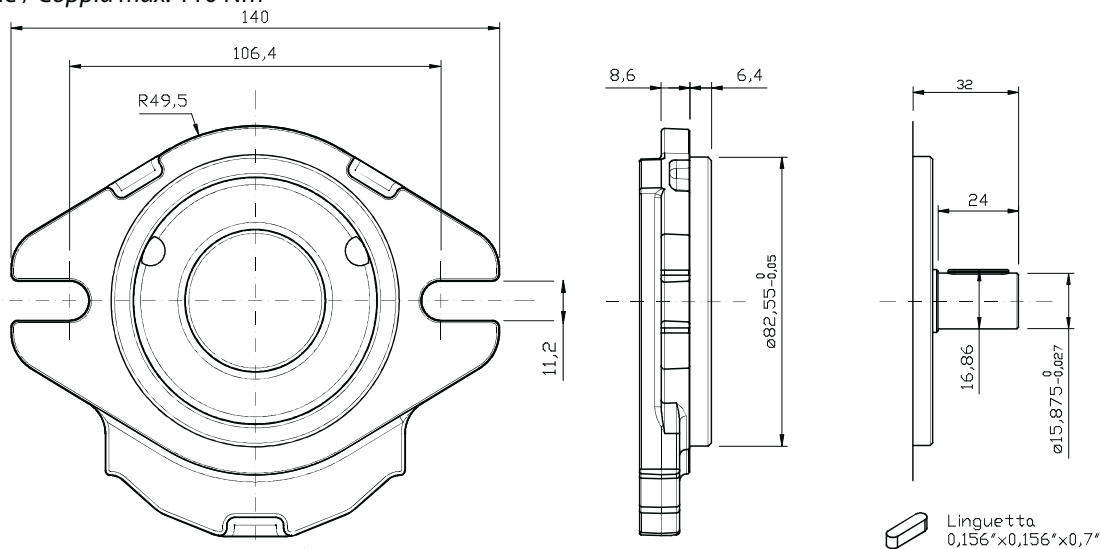

GR38 - TYPE / TIPO SAEA-AC

Type Tipo	CC	L/min	Dimensions A Dimensioni A	Dimensions B Dimensioni B	Continuous Pressure Pressione continua	Intermittent Pressure Pressione intermittente (*)	Peak pressure Picco pressione (*)	Noise level Livello rumore
16	15,9	22,8	126,0	55,50	265	280	300	55
18	17,9	25,8	129,0	57,00	247	260	280	55
20	20,0	28,8	132,0	58,50	230	250	270	55
22	22,1	31,8	135,0	60,00	222	240	260	55
25	25,2	36,2	139,5	62,25	200	210	220	55
28	28,3	40,7	144,0	64,50	180	190	200	55

Max torque / Coppia max: 140 Nm

* Intermittent: cycle 20 sec. ON & 3 sec. OFF - Peak: cycle 1 sec. ON & 3 sec OFF. Intermittente: ciclo 20 sec. ON & 3 sec. OFF - Picco: ciclo 1 sec. ON & 3 sec OFF

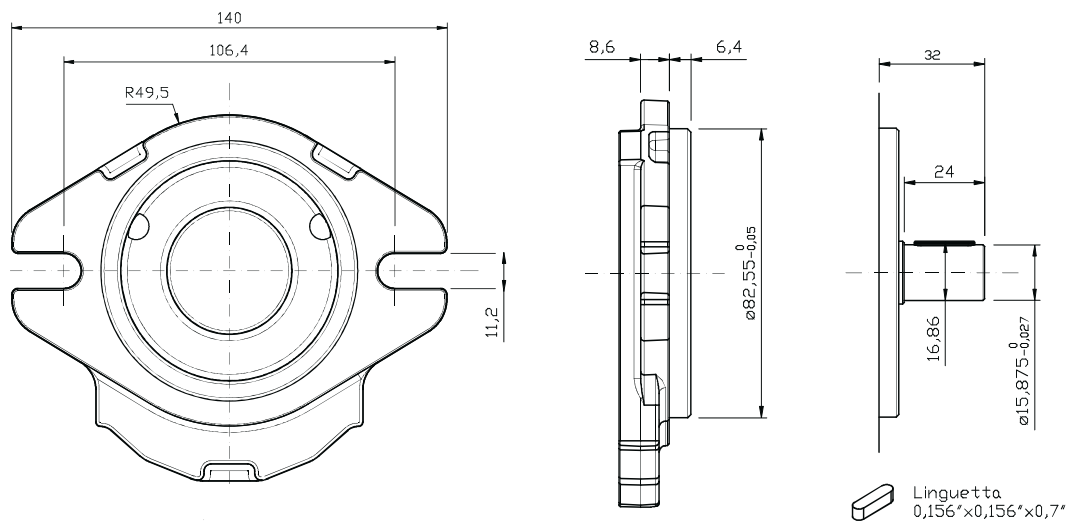

GR38 - TYPE / TIPO SAEA-AC SAE O-RING PORT UNF

Type Tipo	CC	L/min	Dimensions A Dimensioni A	Dimensions B Dimensioni B	Continuous Pressure Pressione continua	Intermittent Pressure Pressione intermittente (*)	Peak pressure Picco pressione (*)	Noise level Livello rumore
16	15,9	22,8	126,0	55,50	265	280	300	55
18	17,9	25,8	129,0	57,00	247	260	280	55
20	20,0	28,8	132,0	58,50	230	250	270	55
22	22,1	31,8	135,0	60,00	222	240	260	55
25	25,2	36,2	139,5	62,25	200	210	220	55
28	28,3	40,7	144,0	64,50	180	190	200	55

Max torque / Coppia max: 140 Nm

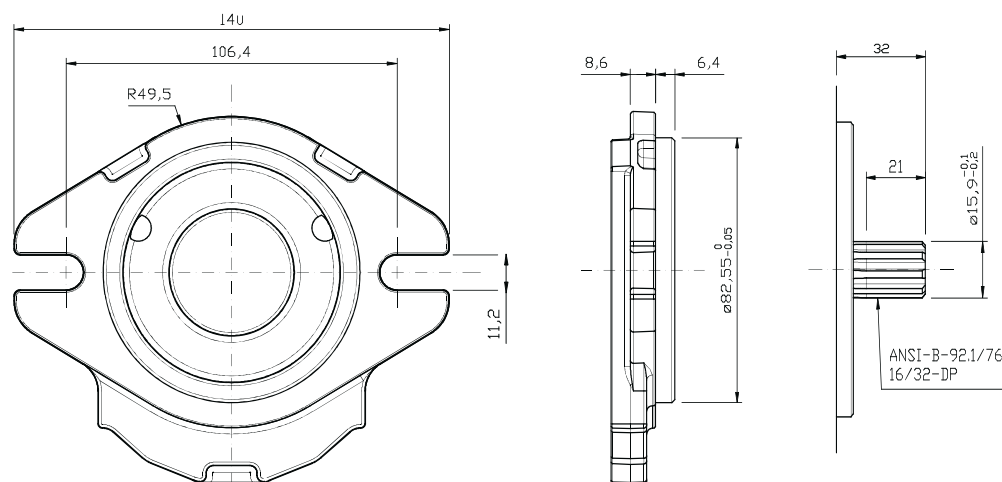

GR38 - TYPE / TIPO SAEA-T9

Type Tipo	CC	L/min	Dimensions A Dimensioni A	Dimensions B Dimensioni B	Continuous Pressure Pressione continua	Intermittent Pressure Pressione intermittente (*)	Peak pressure Picco pressione (*)	Noise level Livello rumore
16	15,9	22,8	126,0	55,50	265	280	300	55
18	17,9	25,8	129,0	57,00	247	260	280	55
20	20,0	28,8	132,0	58,50	230	250	270	55
22	22,1	31,8	135,0	60,00	222	240	260	55
25	25,2	36,2	139,5	62,25	200	210	220	55
28	28,3	40,7	144,0	64,50	180	190	200	55

Max torque / Coppia max: 190 Nm

* Intermittent: cycle 20 sec. ON & 3 sec. OFF - Peak: cycle 1 sec. ON & 3 sec OFF. Intermittente: ciclo 20 sec. ON & 3 sec. OFF - Picco: ciclo 1 sec. ON & 3 sec OFF

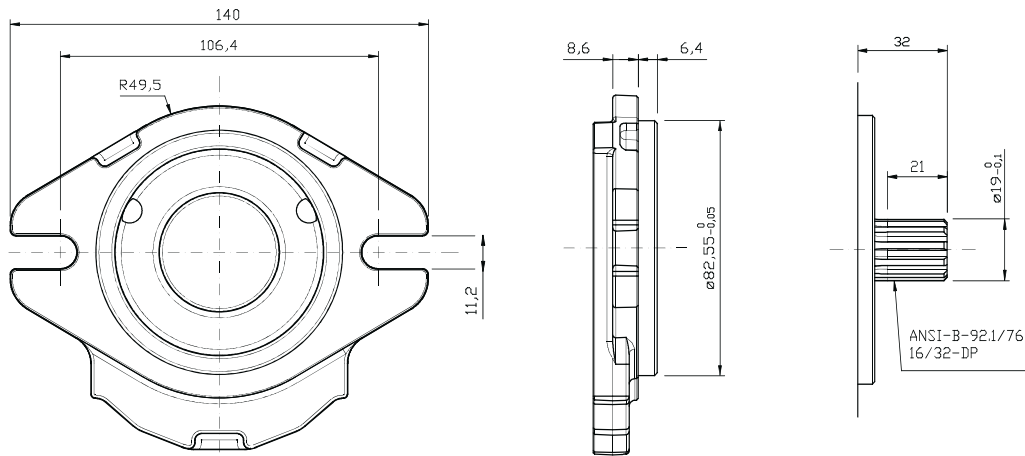

GR38 - TYPE / TIPO SAE-A11

Type Tipo	CC	L/min	Dimensions A Dimensioni A	Dimensions B Dimensioni B	Continuous Pressure Pressione continua	Intermittent Pressure Pressione intermittente (*)	Peak pressure Picco pressione (*)	Noise level Livello rumore
16	15,9	22,8	126,0	55,50	265	280	300	55
18	17,9	25,8	129,0	57,00	247	260	280	55
20	20,0	28,8	132,0	58,50	230	250	270	55
22	22,1	31,8	135,0	60,00	222	250	270	55
25	25,2	36,2	139,5	62,25	208	250	270	55
28	28,3	40,7	144,0	64,50	197	250	270	55

Max torque / Coppia max: 210 Nm

* Intermittent: cycle 20 sec. ON & 3 sec. OFF - Peak: cycle 1 sec. ON & 3 sec OFF. Intermittente: ciclo 20 sec. ON & 3 sec. OFF - Picco: ciclo 1 sec. ON & 3 sec OFF

INLET OUTLET PORTS / PORTE DI ASPIRAZIONE E MANDATA (Suction / Pressure)

Type G / Tipo G

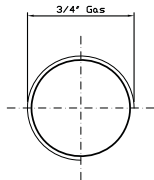

Type Q / Tipo Q

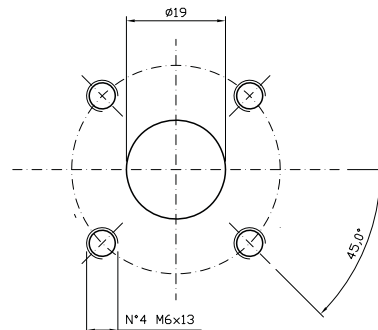

Type M / Tipo M

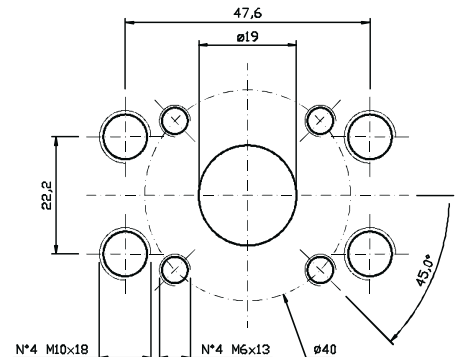

UNF INLET OUTLET PORTS / PORTE DI ASPIRAZIONE E MANDATA UNF - Type U / Tipo U

SAE O-Ring Port 12 thread
ANSI B1.1 1 1/16 UN-2B

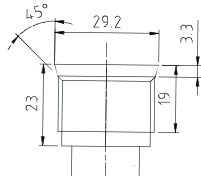

SAE O-Ring Port 16 thread
ANSI B1.1 1 5/16 12 UN-2B

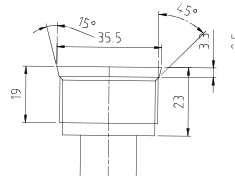

Suction

SAE O-Ring Port 10 thread
ANSI B1.1 7/8 14 UNF-2B

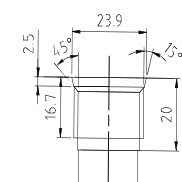

SAE O-Ring Port 12 thread
ANSI B1.1 1 1/16 12 UN-2B

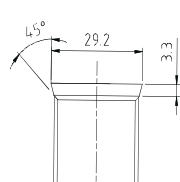

Pressure

Suction/Pressure UNF ports possible configuration
Possibili combinazioni porte di aspirazione/mandata di tipo UNF

Pump	Suction port	Pressure port
GR38 - 16 cc	SAE O-Ring port 12	SAE O-Ring port 10
GR38 - 18 cc	SAE O-Ring port 16	SAE O-Ring port 12
GR38 - 20 cc	SAE O-Ring port 16	SAE O-Ring port 12
GR38 - 22 cc	SAE O-Ring port 16	SAE O-Ring port 12
GR38 - 25 cc	SAE O-Ring port 16	SAE O-Ring port 12
GR38 - 28 cc	SAE O-Ring port 16	SAE O-Ring port 12
GR38 - 50 cc	SAE O-Ring port 16	SAE O-Ring port 12

GR47 - Dimensional drawings / Disegni dimensionali

GR47 SHAFT AND FLANGE TYPE AND DIMENSIONS / TIPO ALBERO E FLANGE E DIMENSIONI

Group 3 pumps / Pompe gruppo 3

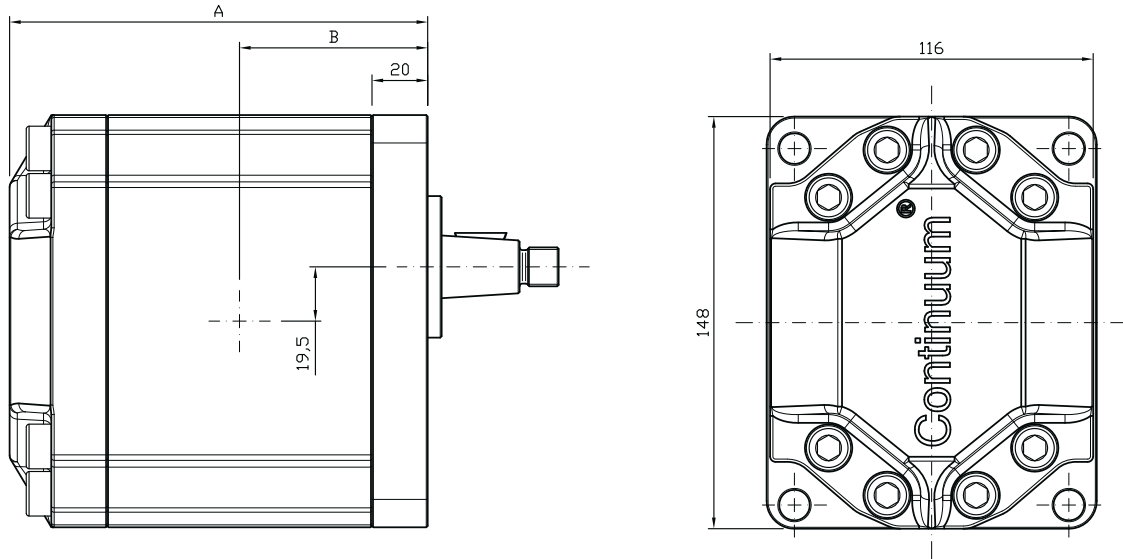

Available flanges and shafts / Flange ed alberi disponibili

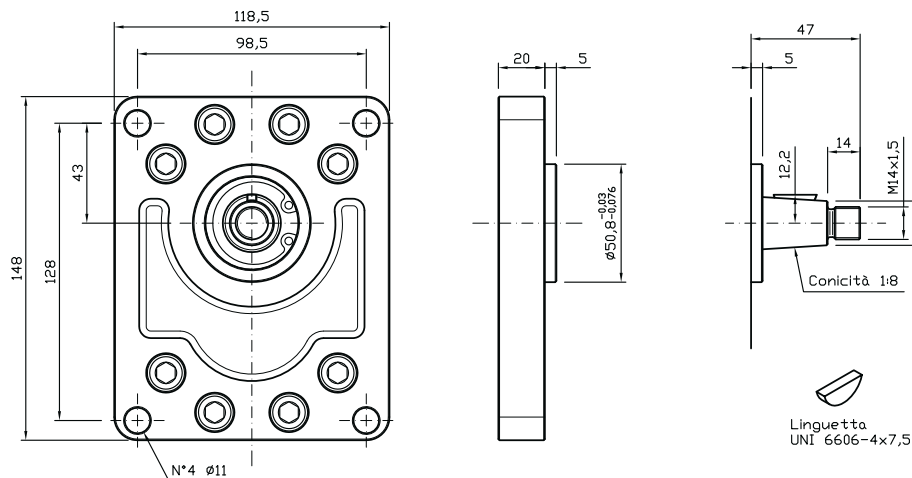

GR47 - TYPE / TIPO 3-C9

Type Tipo	CC	L/min	Dimensions A Dimensioni A	Dimensions B Dimensioni B	Continuous Pressure Pressione continua	Intermittent Pressure Pressione intermittente (*)	Peak pressure Picco pressione (*)	Noise level Livello rumore
28	28,0	40,3	151,5	67,50	270	280	300	57
32	32,2	46,3	155,5	69,50	252	270	280	57
36	36,3	52,3	159,5	71,50	239	250	270	57
40	40,5	58,3	163,5	73,50	225	250	270	57
45	45,5	65,0	168,0	75,75	213	250	270	57
50	50,3	72,4	173,0	78,25	202	250	270	57

Max torque / Coppia max: 320 Nm

* Intermittent: cycle 20 sec. ON & 3 sec. OFF - Peak: cycle 1 sec. ON & 3 sec OFF. Intermittente: ciclo 20 sec. ON & 3 sec. OFF - Picco: ciclo 1 sec. ON & 3 sec OFF

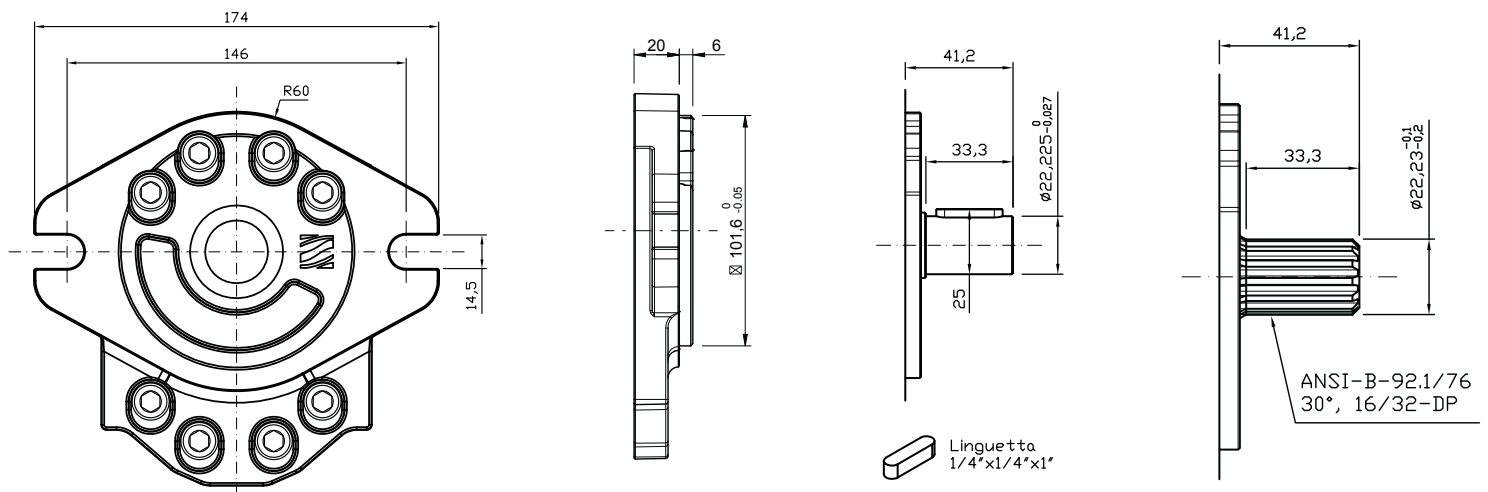

GR47 - TYPE / TIPO SAEB-AC / SAEB-T13

Type Tipo	CC	L/min	Dimensions A Dimensioni A	Dimensions B Dimensioni B	Continuous Pressure Pressione continua	Intermittent Pressure Pressione intermittente (*)	Peak pressure Picco pressione (*)	Noise level Livello rumore
28	28,0	40,3	151,5	67,50	270	280	300	57
32	32,2	46,3	155,5	69,50	252	270	280	57
36	36,3	52,3	159,5	71,50	239	250	270	57
40	40,5	58,3	163,5	73,50	225	250	270	57
45	45,5	65,0	168,0	75,75	213	250	270	57
50	50,3	72,4	173,0	78,25	202	250	270	57

Max torque / Coppia max: 450 Nm - Max torque / Coppia max: 600 Nm

* Intermittent: cycle 20 sec. ON & 3 sec. OFF - Peak: cycle 1 sec. ON & 3 sec OFF. Intermittente: ciclo 20 sec. ON & 3 sec. OFF - Picco: ciclo 1 sec. ON & 3 sec OFF

GR47 INLET OUTLET PORTS / PORTE DI ASPIRAZIONE E MANDATA

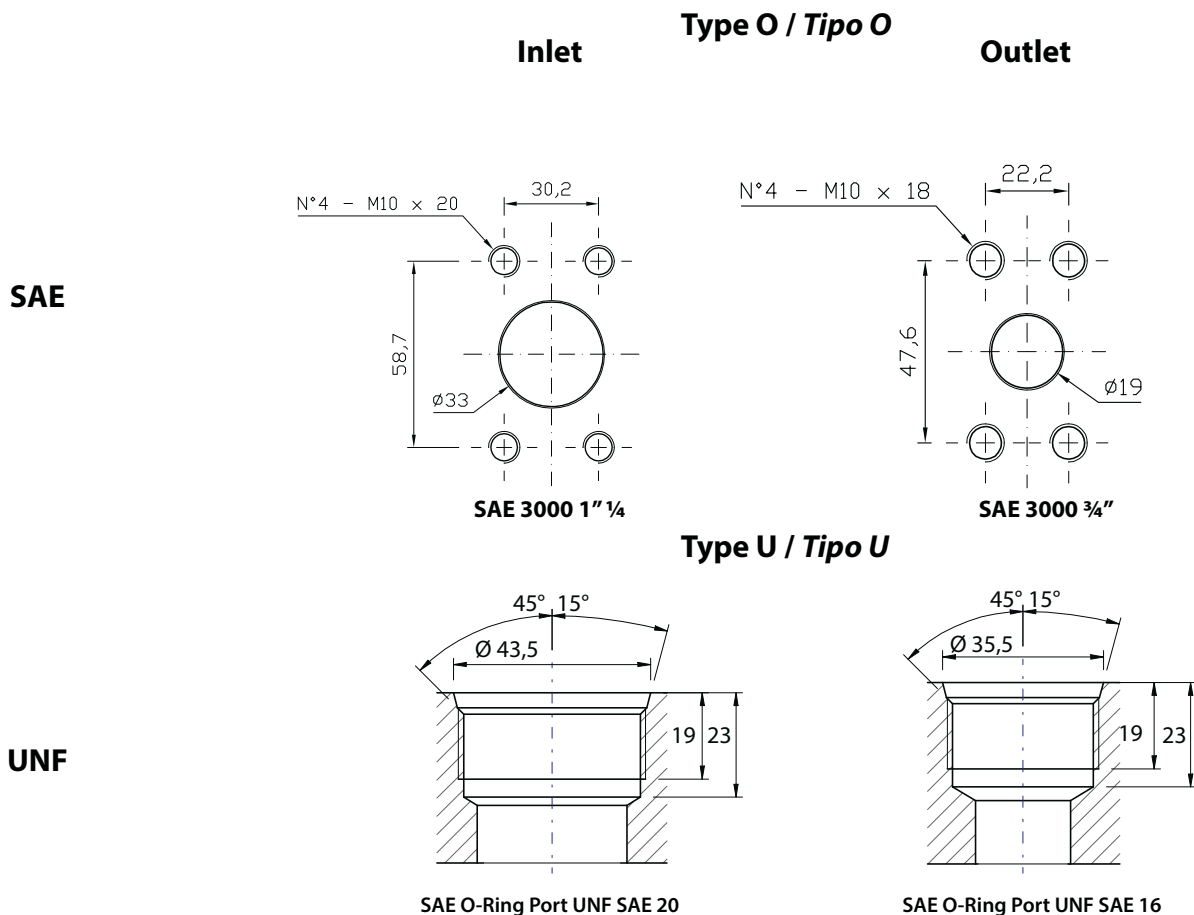

GR55 - Dimensional drawings / Disegni dimensionali

GR55 SHAFT AND FLANGE TYPE AND DIMENSIONS / TIPO ALBERO E FLANGE E DIMENSIONI

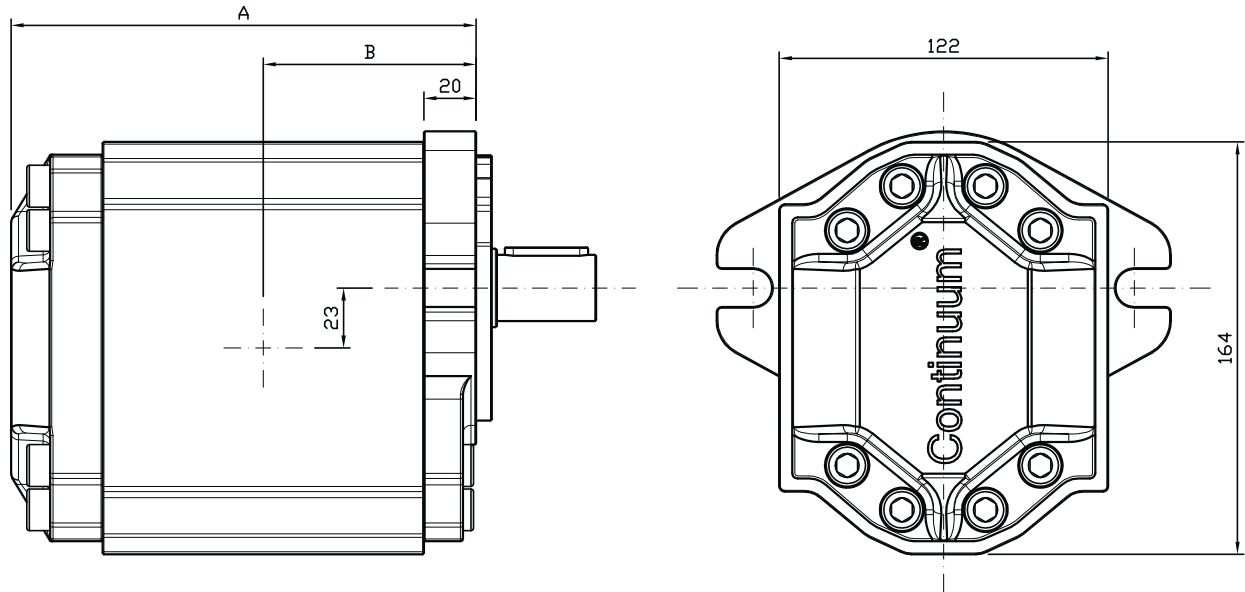

Available flanges and shafts / Flange ed alberi disponibili

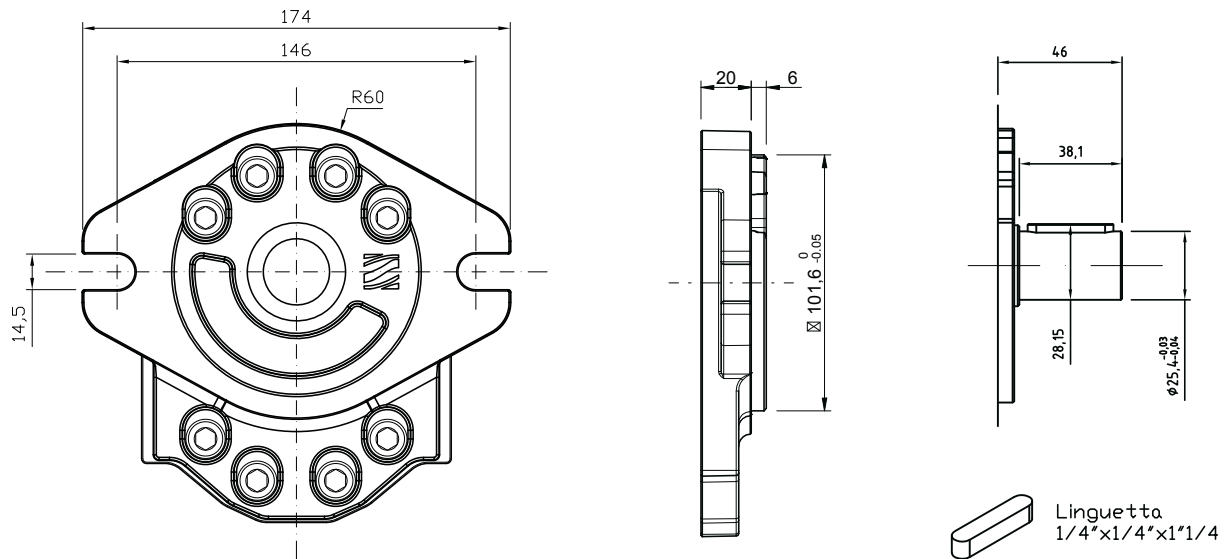

GR55 - TYPE / TIPO SAEB-AC

Type Tipo	CC	L/min	Dimensions A Dimensioni A	Dimensions B Dimensioni B	Continuous Pressure Pressione continua	Intermittent Pressure Pressione intermittente (*)	Peak pressure Picco pressione (*)	Noise level Livello rumore
50	50,5	72,7	179,5	81,50	275	280	300	57
63	63,5	91,4	188,5	86,00	249	260	280	57
75	75,0	108,1	196,5	90,00	229	250	270	57
90	90,9	130,9	207,5	95,5	178	240	260	57

* Intermittent: cycle 20 sec. ON & 3 sec. OFF - Peak: cycle 1 sec. ON & 3 sec OFF. Intermittente: ciclo 20 sec. ON & 3 sec. OFF - Picco: ciclo 1 sec. ON & 3 sec OFF
Max torque / Coppia max: 550 Nm

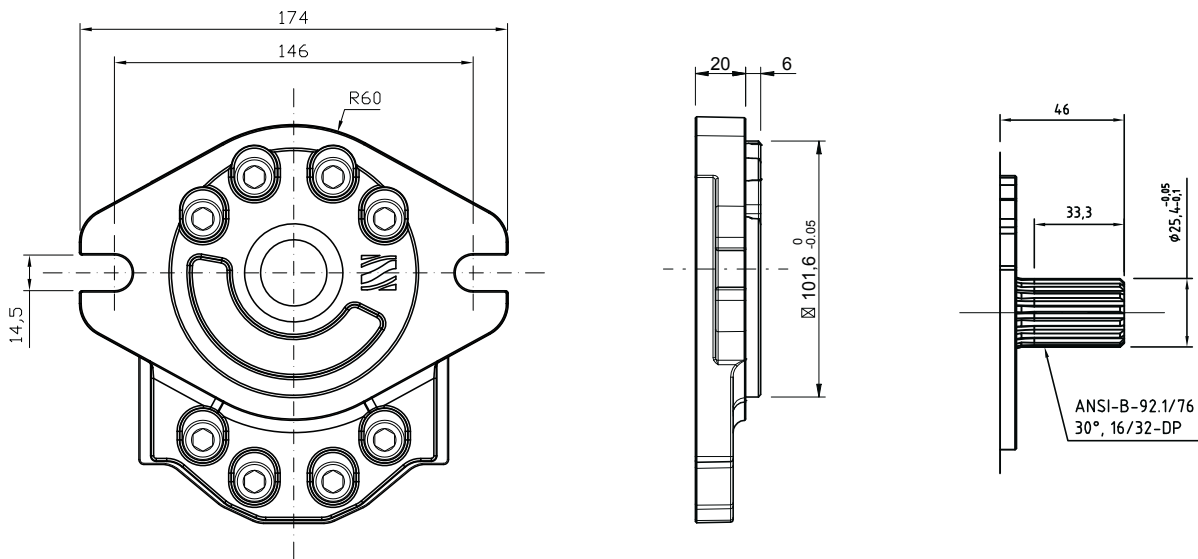

GR55 - TYPE / TIPO SAEB-T15

Type Tipo	CC	L/min	Dimensions A Dimensioni A	Dimensions B Dimensioni B (**)	Continuous Pressure Pressione continua	Intermittent Pressure Pressione intermittente (*)	Peak pressure Picco pressione (*)	Noise level Livello rumore
50	50,5	72,7	179,5	81,50	275	280	300	57
63	63,5	91,4	188,5	86,00	249	260	280	57
75	75,0	108,1	196,5	90,00	229	250	270	57
90	90,9	130,9	207,5	95,50	178	240	260	57

Max torque / Coppia max: 700 Nm

* Intermittent: cycle 20 sec. ON & 3 sec. OFF - Peak: cycle 1 sec. ON & 3 sec OFF. Intermittente: ciclo 20 sec. ON & 3 sec. OFF - Picco: ciclo 1 sec. ON & 3 sec OFF

** Ask SETTIMA the dimensional drawings for "OE" suction port

GR55 INLET OUTLET PORTS / PORTE DI ASPIRAZIONE E MANDATA - Type OE / Tipo OE

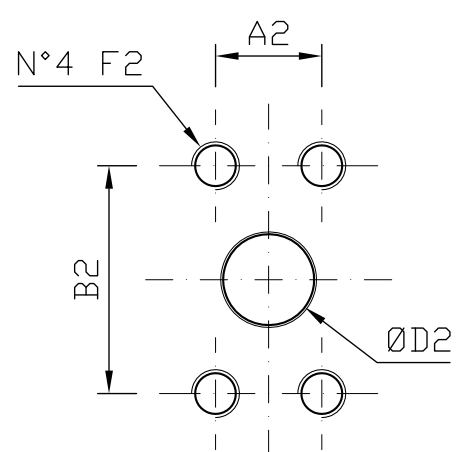
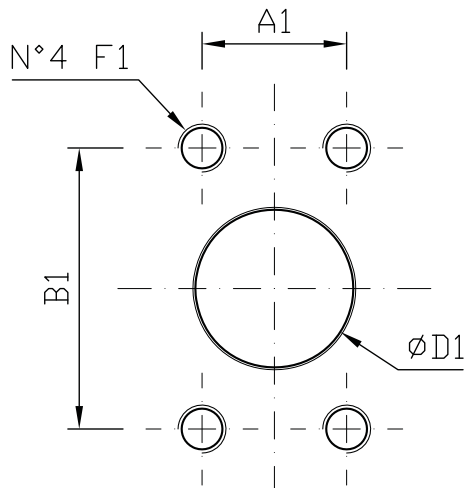

Type port	INLET		
	"O"	"OE"	
Size port	SAE-3000 1" ¼	SAE-3000 1" ¼ only for 50cc	SAE-3000 1" ½
A1	30,20	30,20	35,70
B1	58,70	58,70	69,85
ØD1	33,00	33,00	38,00
F1	M10x20	M10x18	M12x18

Type port	OUTLET	
	"O"	"OE"
Size port	SAE-3000 ¾"	SAE-3000 1"
A2	22,20	26,20
B2	47,60	52,40
ØD2	19,00	25,00
F2	M10X18	M10X18

GR72 - Dimensional drawings / Disegni dimensionali

GR72 SHAFT AND FLANGE TYPE AND DIMENSIONS / TIPO ALBERO E FLANGE E DIMENSIONI

Group 4 pumps / Pompe gruppo 4

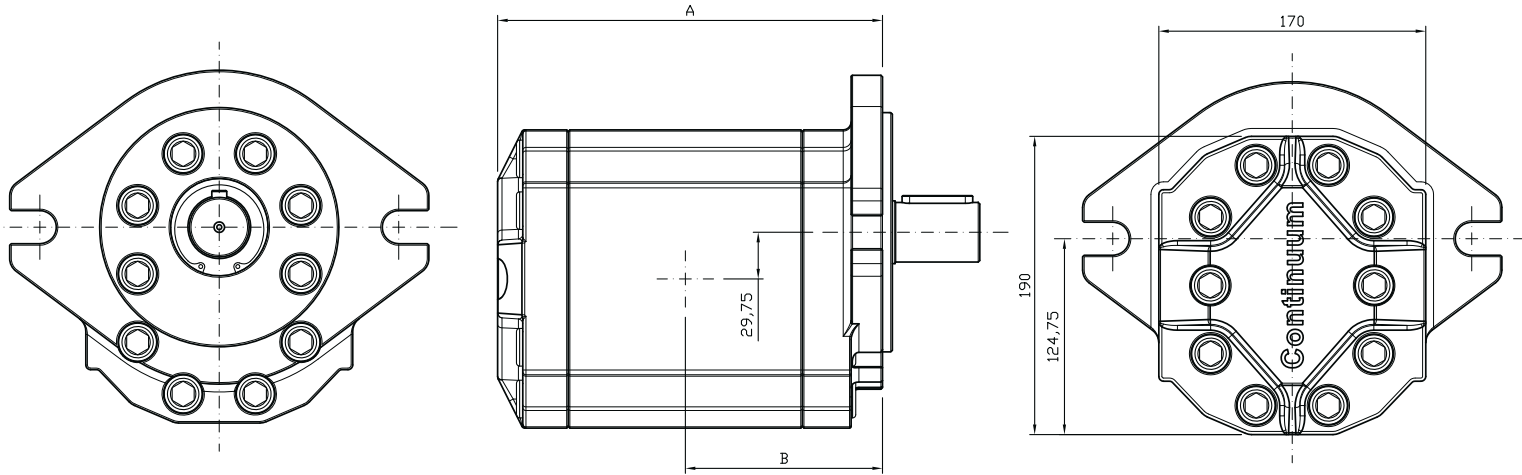

Available flanges and shafts / Flange ed alberi disponibili

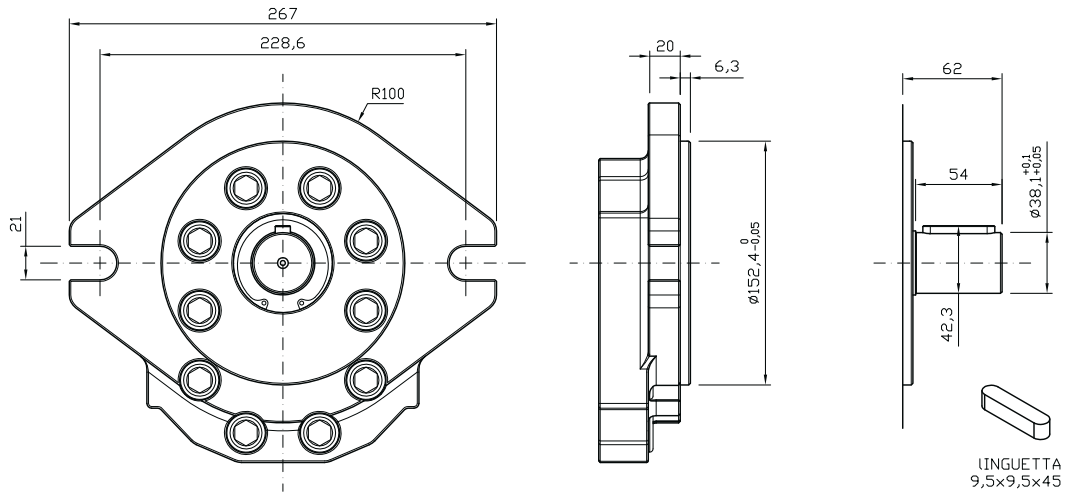

GR72 - TYPE / TIPO SAED-AC

Type Tipo	CC	L/min	Dimensions A Dimensioni A	Dimensions B Dimensioni B	Continuous Pressure Pressione continua	Intermittent Pressure Pressione intermittente (*)	Peak pressure Picco pressione (*)	Noise level Livello rumore
94	94,1	136	245,0	125,65	240	250	260	57
101	101,4	147	248,0	127,05	230	240	250	57
125	125,5	181	258,0	132,15	220	220	230	57
150	150,9	218	268,5	137,40	200	210	220	57
175	175,0	253	278,5	142,40	180	190	200	57
200	200,4	290	289,0	147,65	160	170	180	57

Max torque / Coppia max: 1000 Nm

* Intermittent: cycle 20 sec. ON & 3 sec. OFF - Peak: cycle 1 sec. ON & 3 sec OFF. Intermittente: ciclo 20 sec. ON & 3 sec. OFF - Picco: ciclo 1 sec. ON & 3 sec OFF

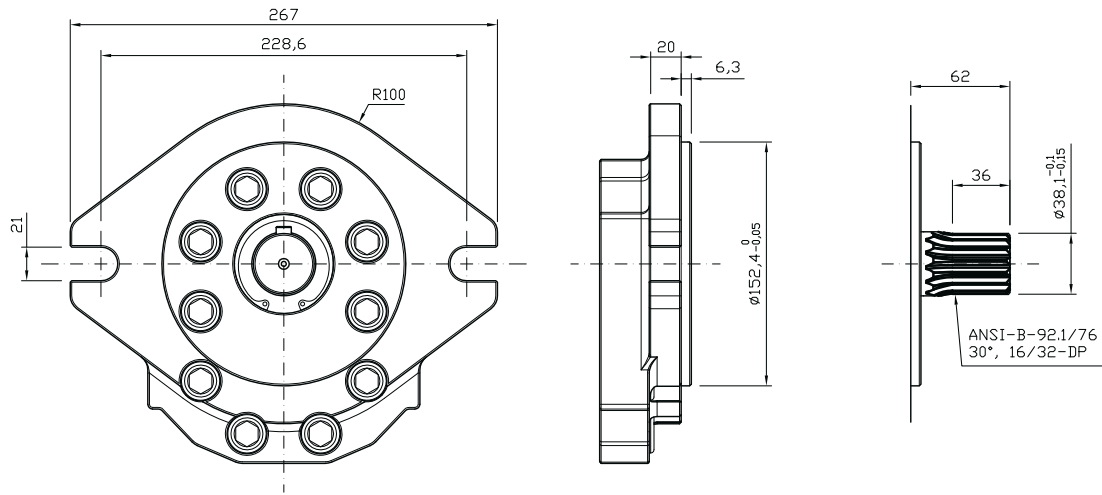

GR72 - TYPE / TIPO SAED-T23								
Type Tipo	CC	L/min	Dimensions A Dimensioni A	Dimensions B Dimensioni B	Continuous Pressure Pressione continua	Intermittent Pressure Pressione intermittente (*)	Peak pressure Picco pressione (*)	Noise level Livello rumore
94	94,1	136	245,0	125,50	240	250	260	57
101	101,4	147	248,0	127,00	230	240	250	57
125	125,5	181	258,0	132,00	220	220	230	57
150	150,9	218	268,5	137,25	200	210	220	57
175	175,0	253	278,5	142,25	180	190	200	57
200	200,4	290	289,0	147,50	160	170	180	57

Max torque / Coppia max: 1200 Nm

* Intermittent: cycle 20 sec. ON & 3 sec. OFF - Peak: cycle 1 sec. ON & 3 sec OFF. Intermittente: ciclo 20 sec. ON & 3 sec. OFF - Picco: ciclo 1 sec. ON & 3 sec OFF

GR72 INLET OUTLET PORTS / PORTE DI ASPIRAZIONE E MANDATA - Type ME / Tipo ME

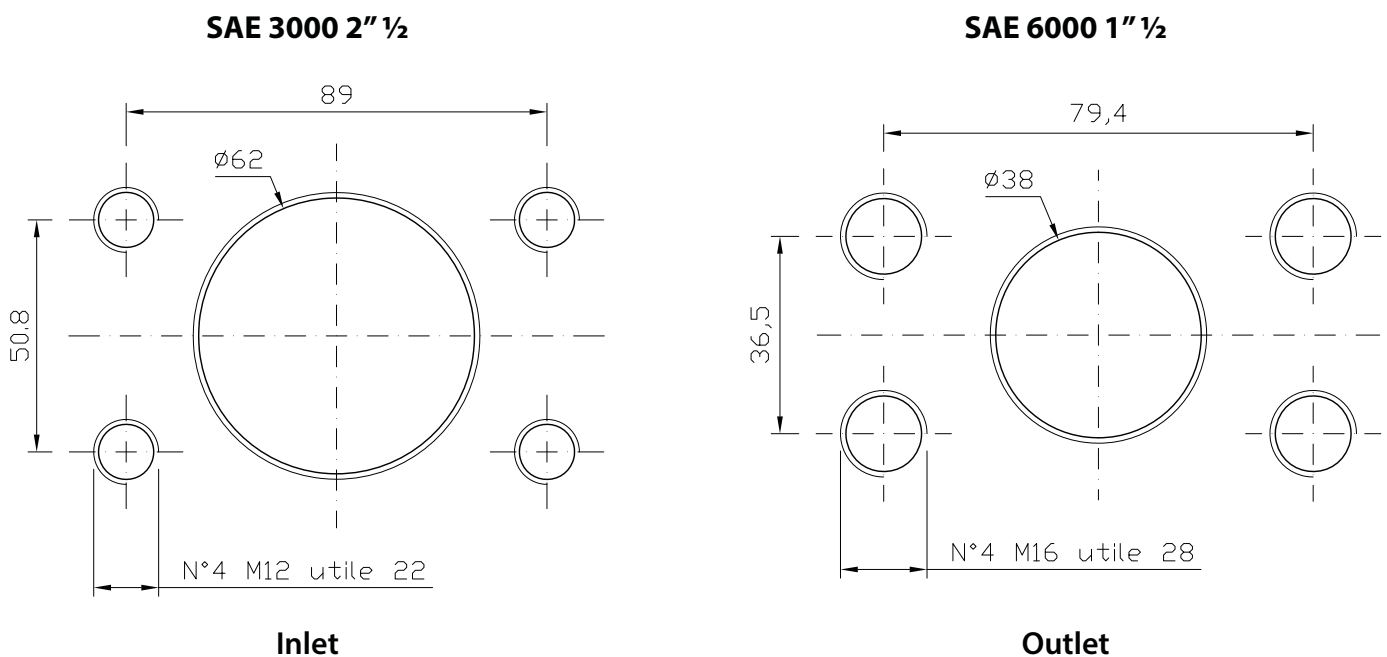

Flow performances @ 46 cSt

GR28 1-C3 / 1L-GL54 / 1L-G54

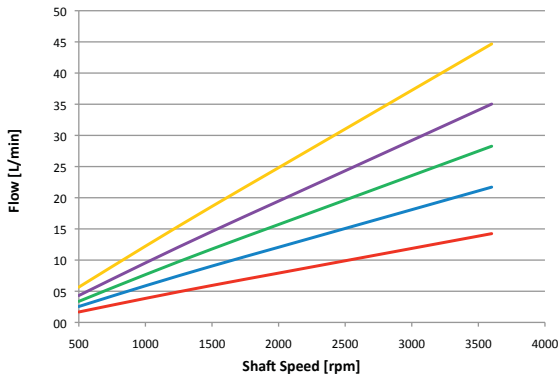

GR28 1P-C2

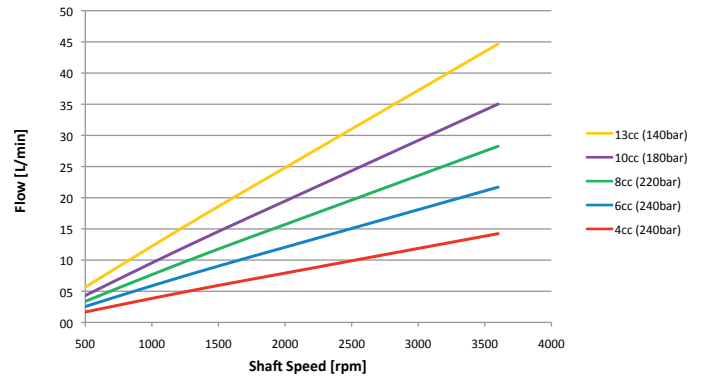

GR28 1K-G54 / 1K-GL54

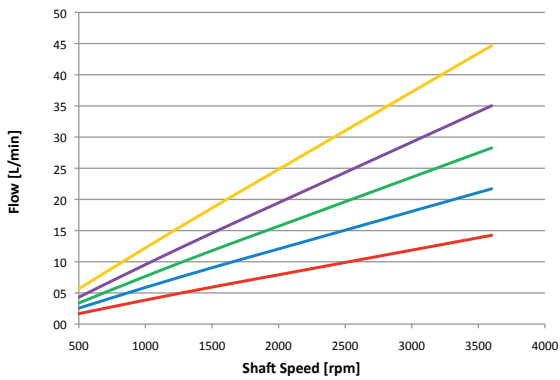

GR28 SAEA-AC

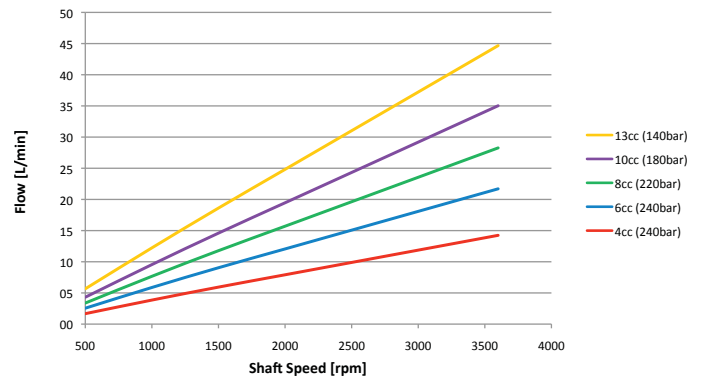

GR33

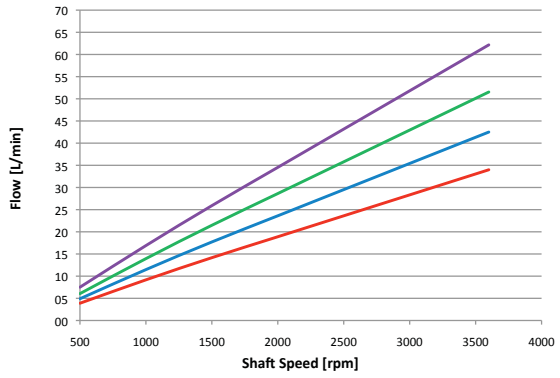

GR38

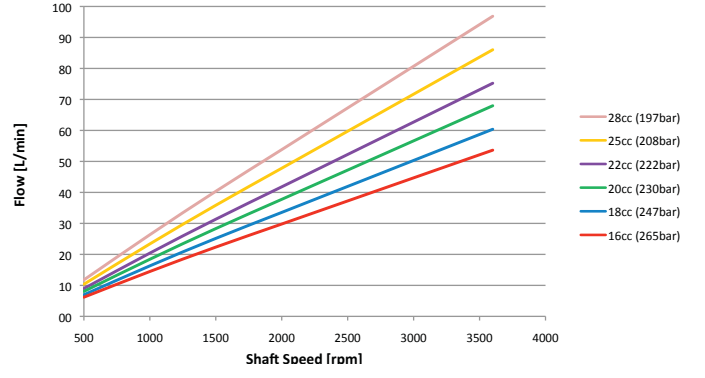

GR38 SAEA-T9

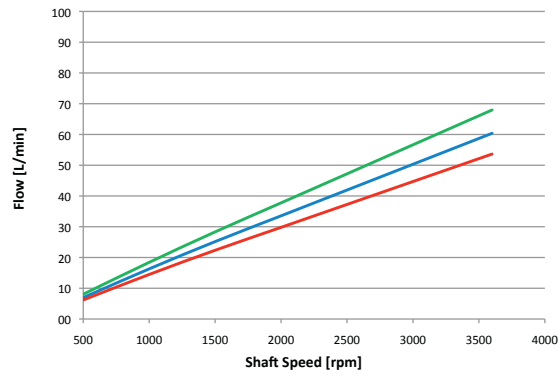

GR47

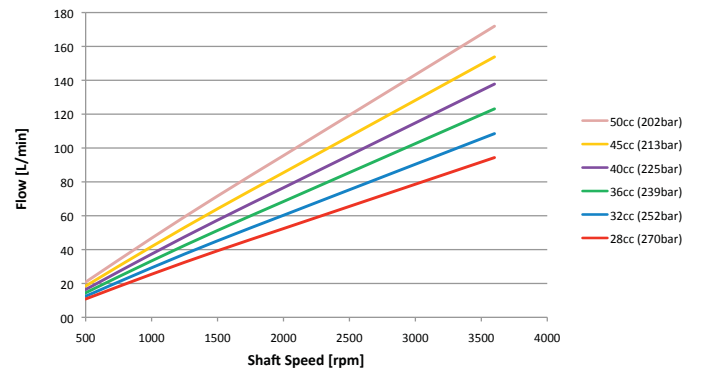

Flow performances @ 46 cSt

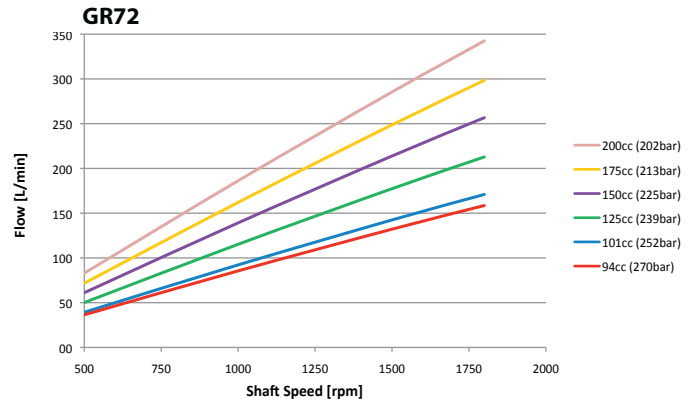
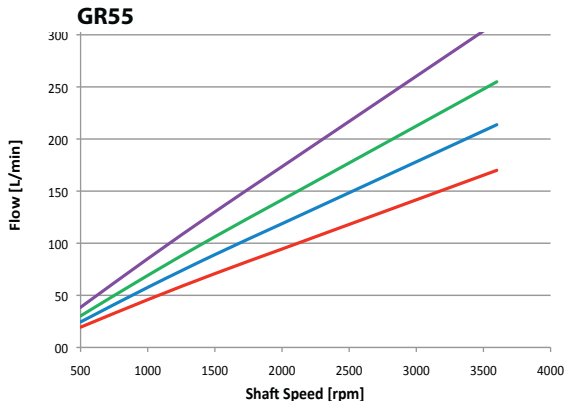

Servo Continuum® pump - *Servopompa Continuum®*

Power-torque performances @ 46 cSt

GR28 4 CC

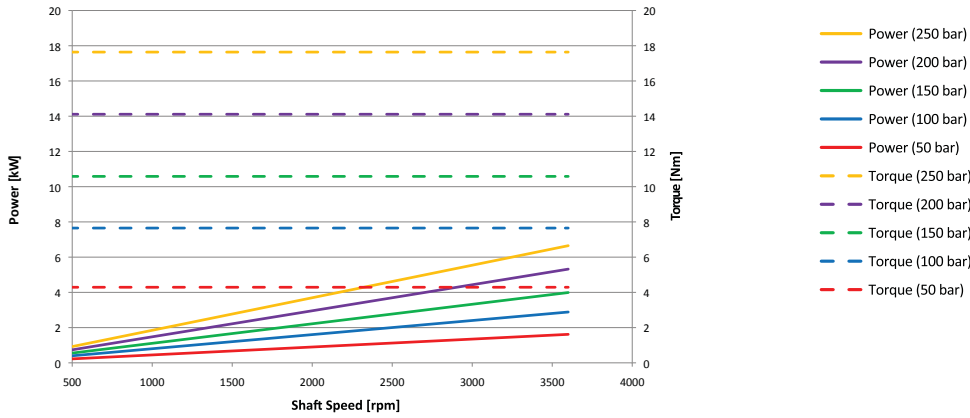

GR28 6 CC

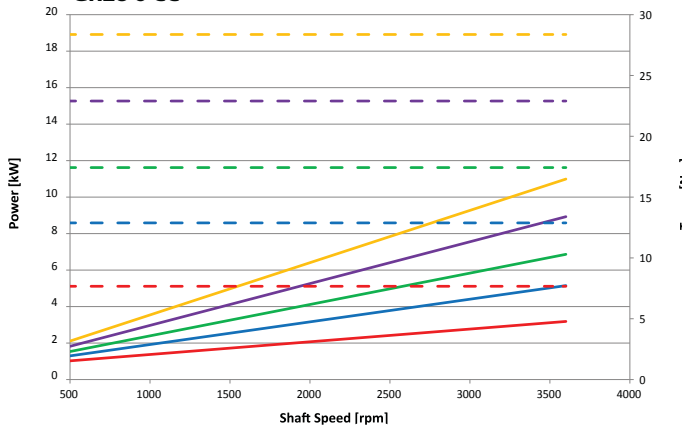

GR28 8 CC

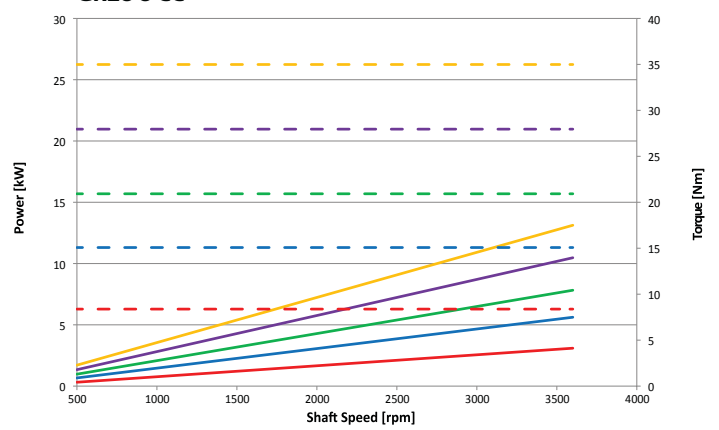

GR28 10 CC

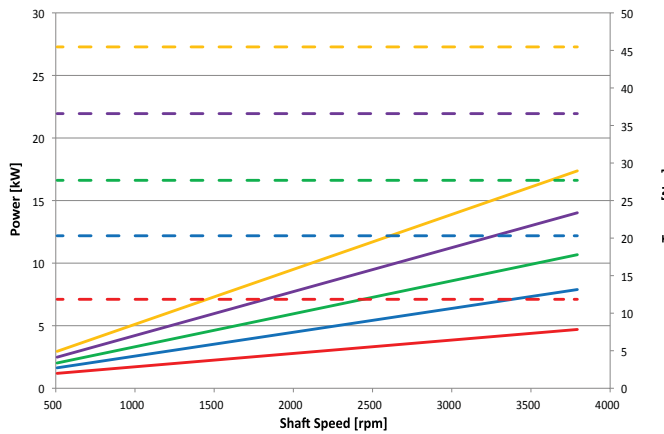

GR28 13 CC

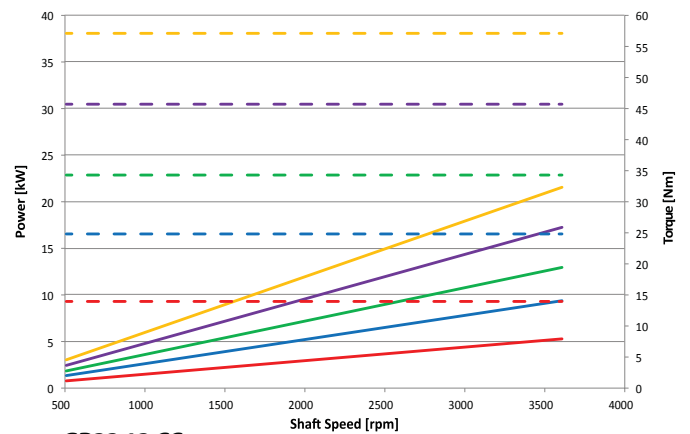

GR33 10 CC

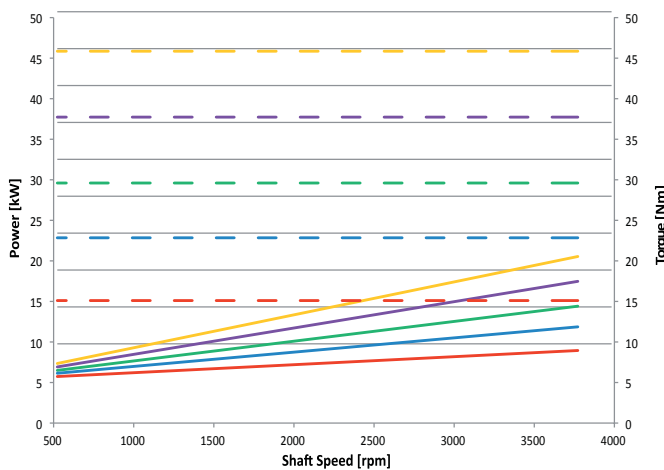

GR33 13 CC

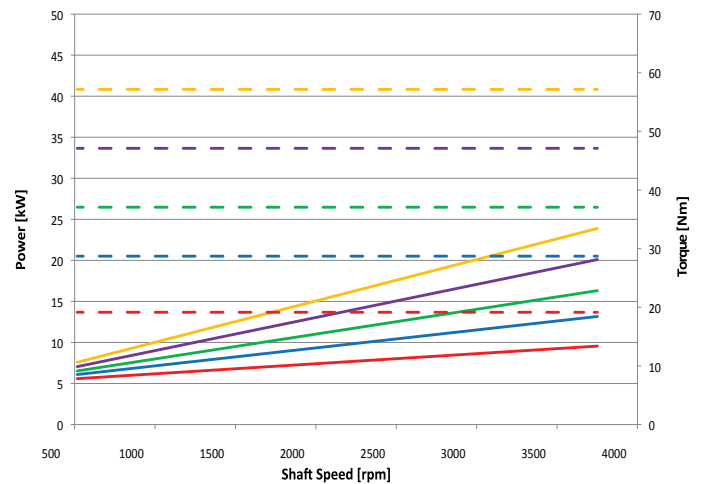

Power-torque performances @ 46 cSt

GR33 15 CC

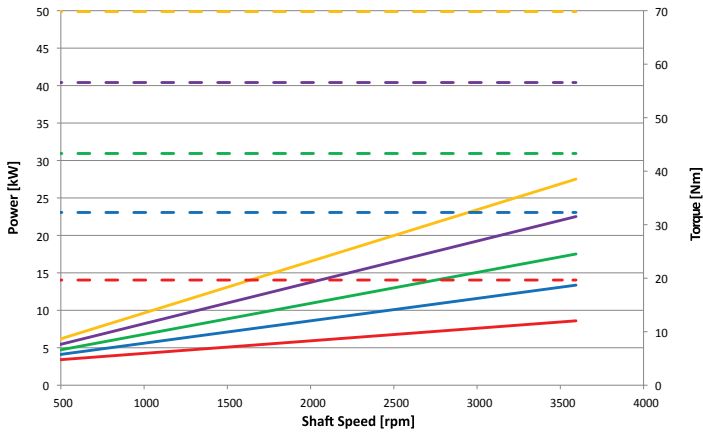

GR33 18 CC

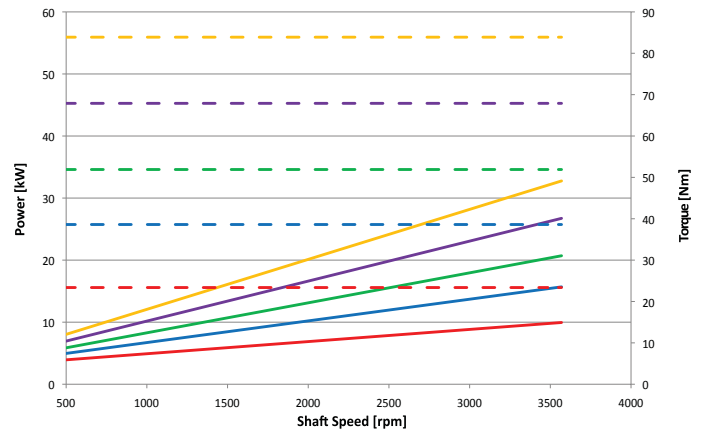

GR38 16 CC

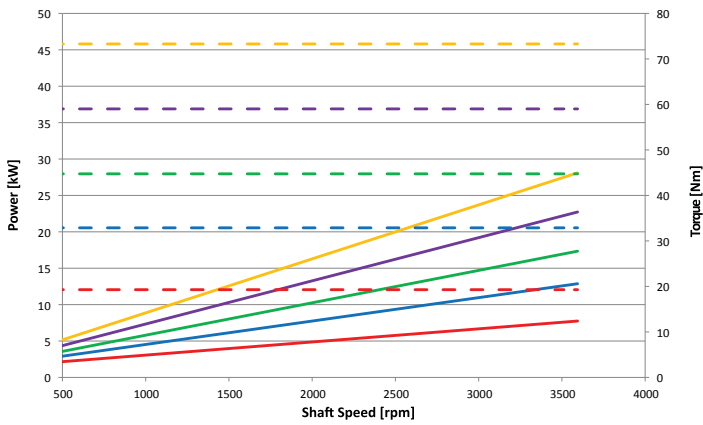

GR38 18 CC

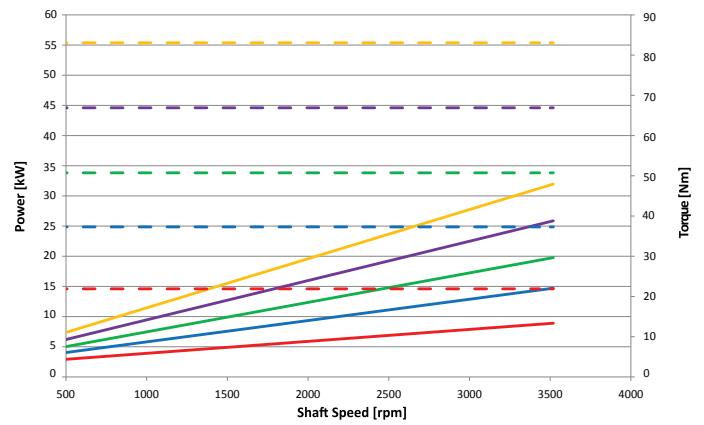

GR38 20 CC

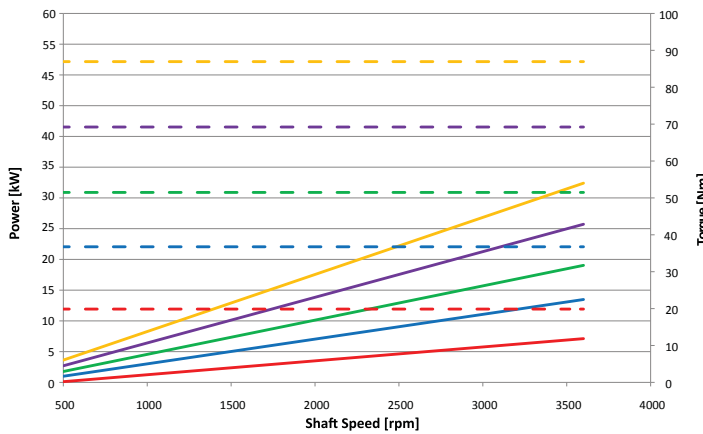

GR38 22 CC

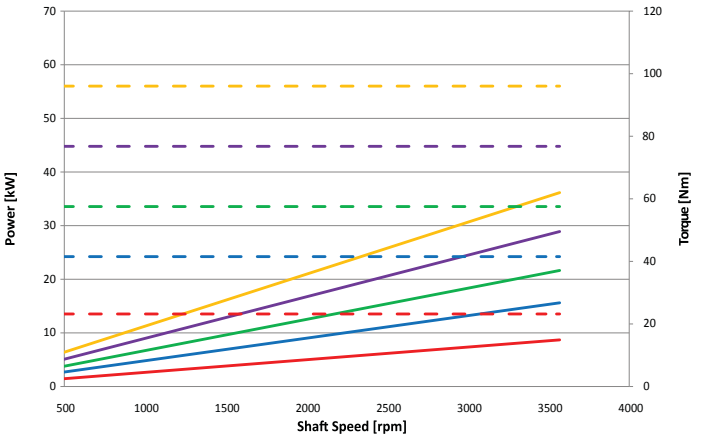

GR38 25 CC

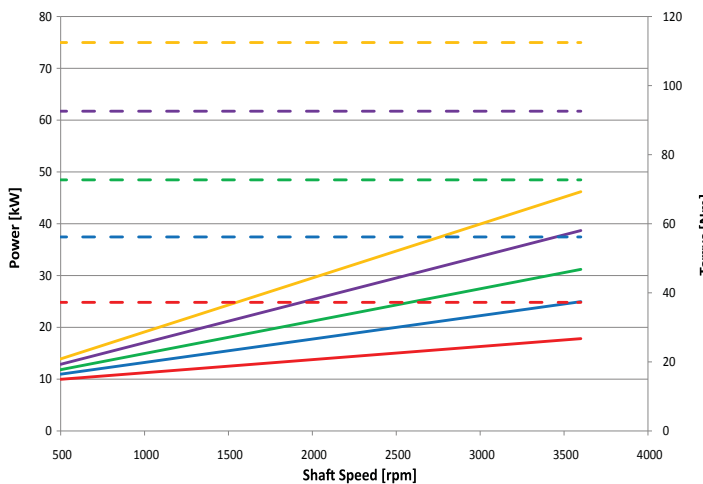

GR38 28 CC

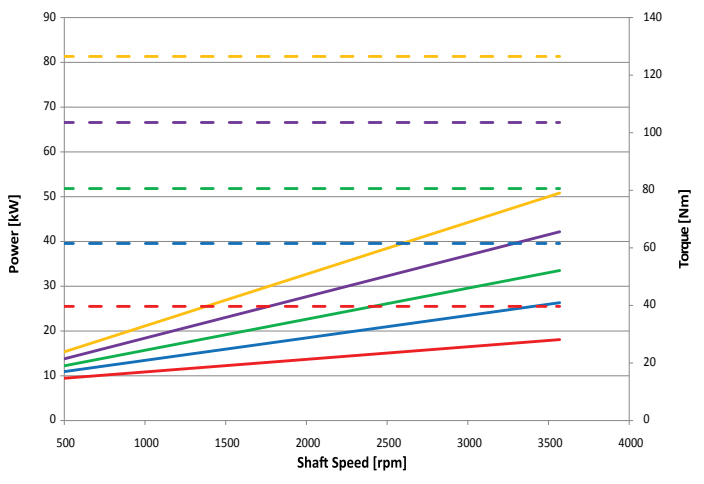

Power-torque performances @ 46 cSt

GR47 28 CC

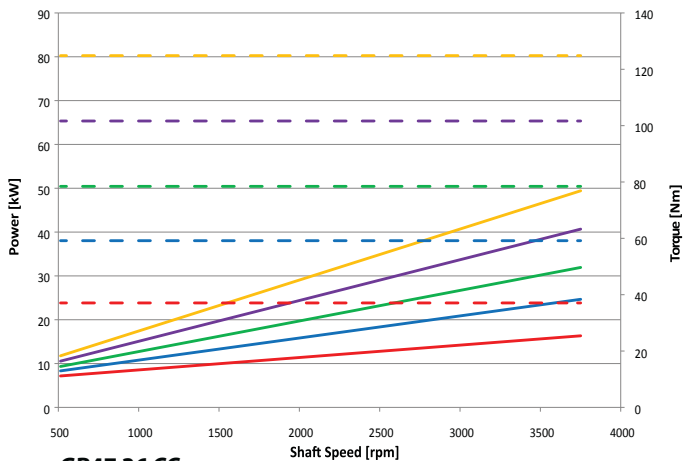

GR47 32 CC

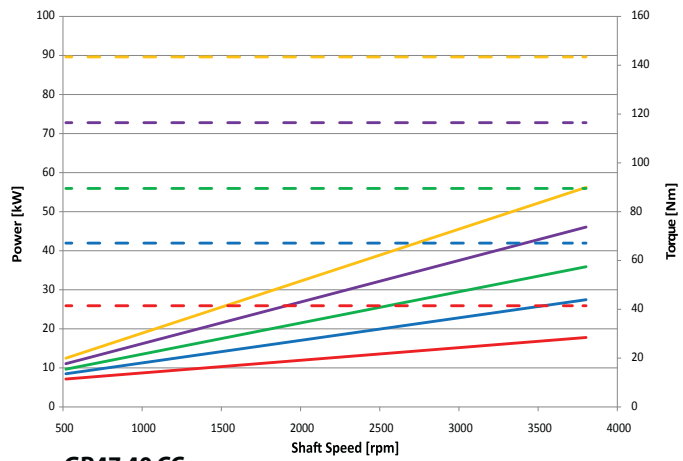

GR47 36 CC

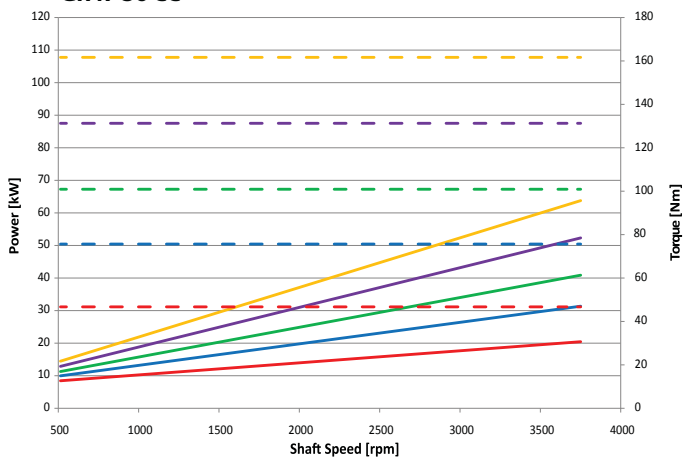

GR47 40 CC

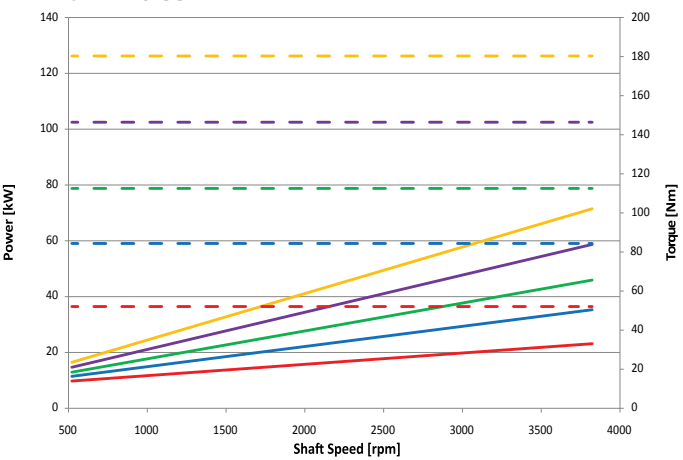

GR47 45 CC

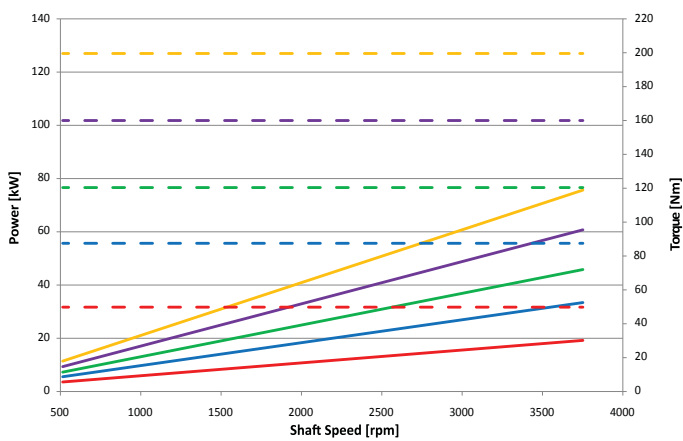

GR47 50 CC

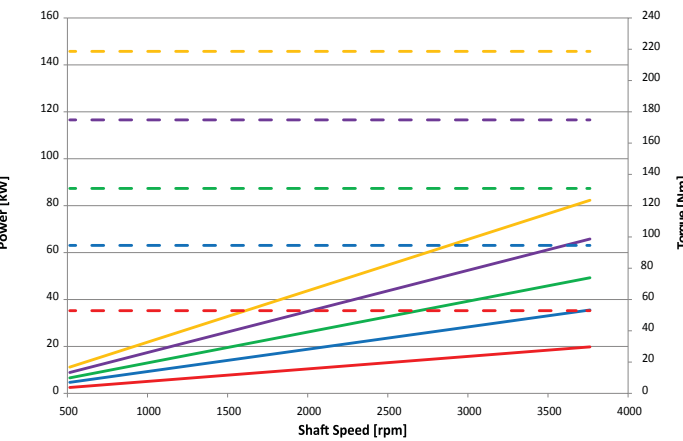

GR55 50 CC

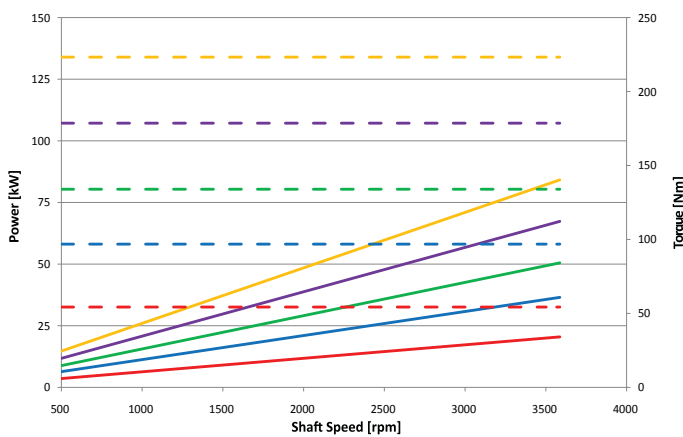

GR55 63 CC

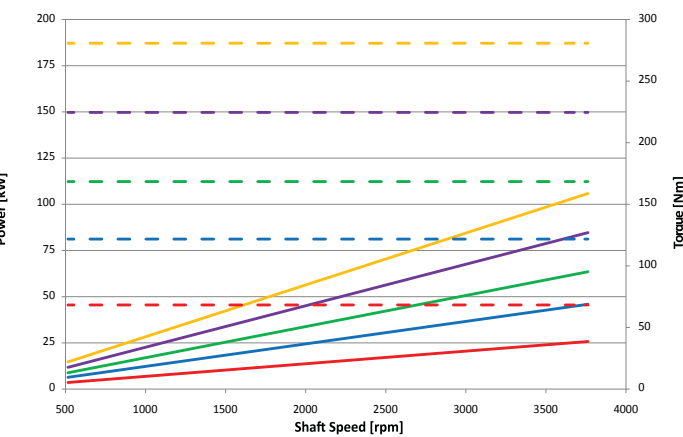

Power-torque performances @ 46 cSt

GR55 75

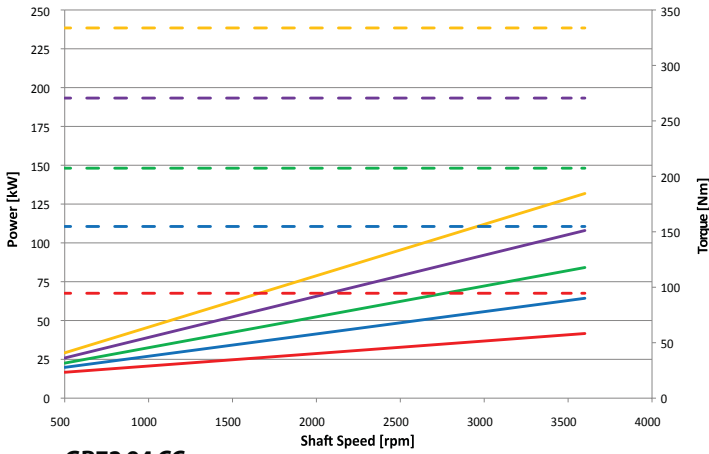

GR55 90 CC

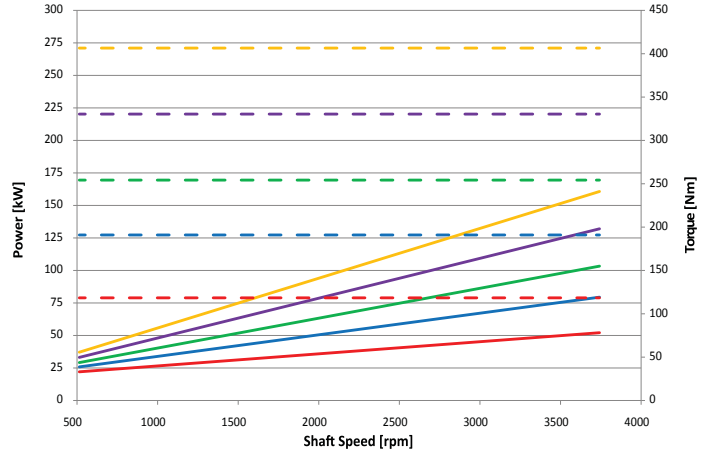

GR72 94 CC

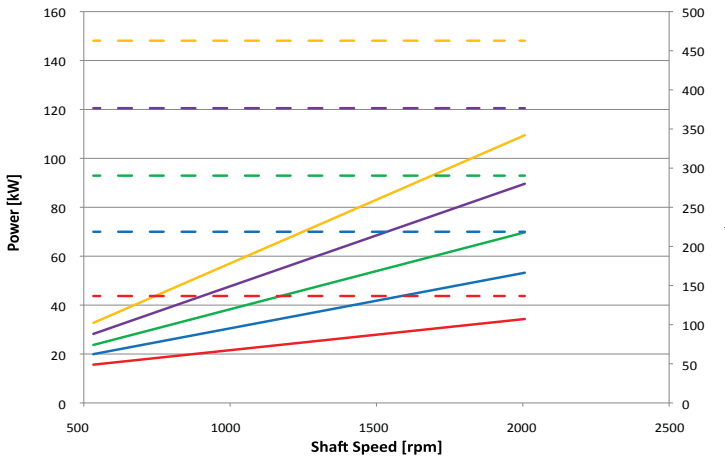

GR72 101 CC

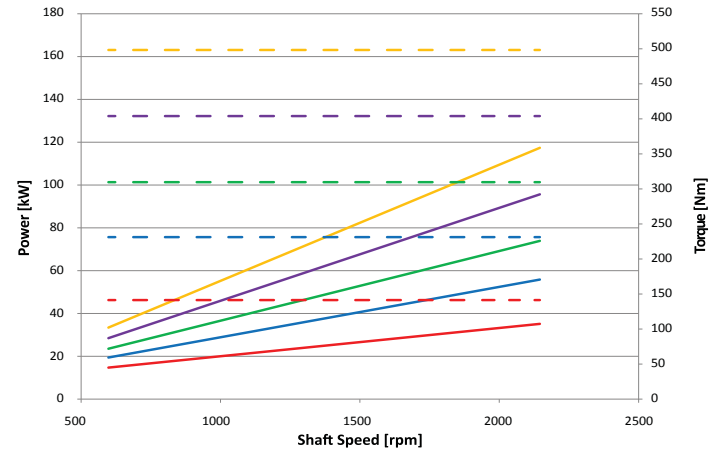

GR72 125 CC

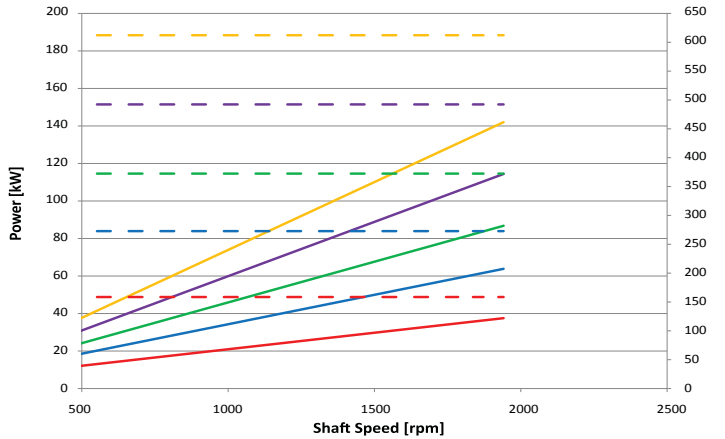

GR72 150 CC

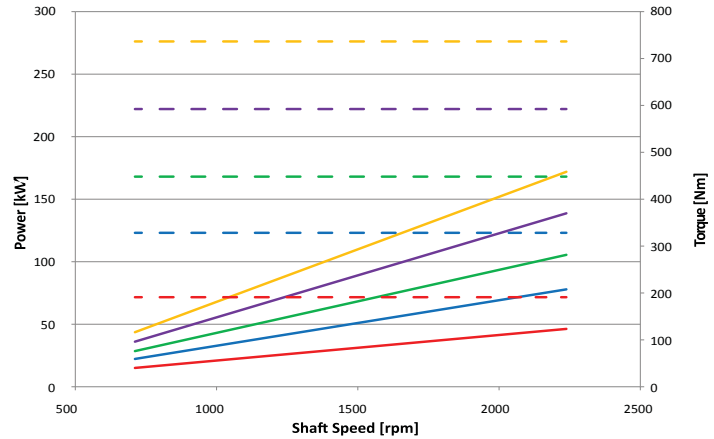

GR72 175 CC

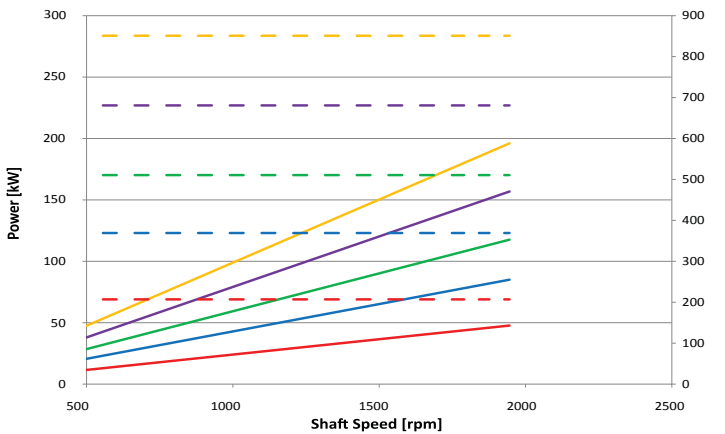

GR72 200 CC

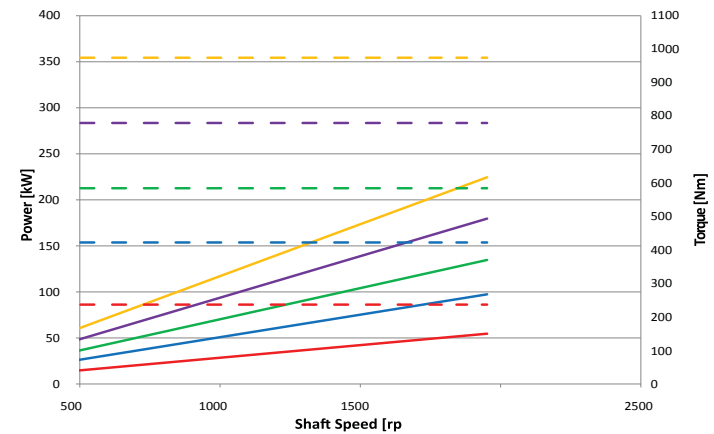



Tandem & multiple pumps / Pompe doppie e multiple

Continuum® pumps are suitable for multiple setups, whereby the drive shaft of the first pump is extended to a second and even a third **Continuum**® pump. Each pump is connected to another by means of coupling. Each pump has its own suction port. Basically the technical specifications of single pumps apply also to multiple setups**. The maximum speed is determined by the highest pump speed rate in use. In case of multiple setup configurations, it is recommended to use the largest displacement for the first pump. The front pump may be equipped with different types of flange and shaft.

Ordering code / Codice ordine

Multiple setups / Pompe multiple

Type Tipo	Class Classe	Displacement Cilindrata	Flange & shaft Flangia & albero	Ports Porte	Type ^{2nd} stage Tipo 2° stadio	Displacement ^{2nd} stage Cilindrata 2° stadio	Ports Porte	Shaft seal Guarnizione albero	Rotation Rotazione
DG28	2V	004-006-008-010-013	F1AC3	G-U	GR28	004-006-008-010-013	G-U	Standard NBR (none) Optional FKM V	Standard DX (none)  Optional SX* 
DG33	2V	010-013-015-018	F2AC4	G-M- Q-U	GR28		G-U		
					GR33	010-013-015-018	G-M-		
					GR38	016-018-020-022-025-028	Q-U		
DG38	2V	016-018-020- 022-025-028	F2AC4	G-M- Q-U	GR28	004-006-008-010-013	G-U		
					GR33	010-013-015-018	G-M-		
					GR38	016-018-020-022-025-028	Q-U		
DG47	2V	028-032-036- 040-045-050	F3AC9 FSAEBAT13	O-U	GR28	004-006-008-010-013	G-U		
					GR33	010-013-015-018	G-M-		
					GR38	016-018-020-022-025-028	Q-U		
					GR47	028-032-036-040-045-050	O-U		
DG55	2V	050-063-075-090	FSAEBAT15	O-OE	GR28	004-006-008-010-013	G-U		
					GR33	010-013-015-018	G-M-		
					GR38	016-018-020-022-025-028	Q-U		
					GR47	028-032-036-040-045-050	O-U		
					GR55	050-063-075-090	O-OE		
DG72	2V	094-101-125- 150-175-200-225	FSAEDAT23	ME	GR47	028-032-036-040-045-050	O-U		
					GR55	050-063-075-090	O-OE		
					GR72	094-101-125-150-175-200	ME		

* Please contact Settima for SX counter clockwise optional rotation. *Contattare Settima per rotazione SX opzionale.*

** The minimum operating pressure recommended for the second stage is 30 bar. In case of lower pressure, please, contact Settima. *Minima pressione di funzionamento consigliata per il secondo stadio 30 bar, al di sotto, contattare Settima.*

GR28 - Group 1 tandem pumps*

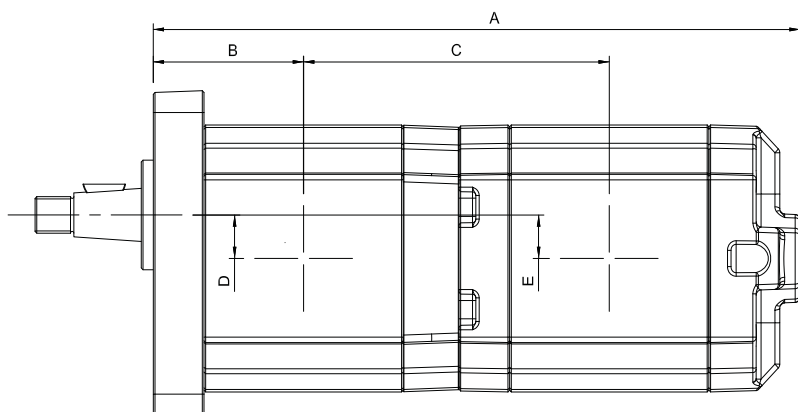

GR28 + GR28		2°				
		4	6	8	10	13
4	A	191,50	-	-	-	-
	B	44,50	-	-	-	-
	C	90,50	-	-	-	-
	D	11,90	-	-	-	-
	E	11,90	-	-	-	-
6	A	197,00	202,50	-	-	-
	B	47,25	47,25	-	-	-
	C	93,25	96,00	-	-	-
	D	11,90	11,90	-	-	-
	E	11,90	11,90	-	-	-
8	A	202,00	207,50	212,50	-	-
	B	49,75	49,75	49,75	-	-
	C	95,75	98,50	101,00	-	-
	D	11,90	11,90	11,90	-	-
	E	11,90	11,90	11,90	-	-
10	A	207,00	212,50	217,50	222,50	-
	B	52,25	52,25	52,25	52,25	-
	C	98,25	101,00	103,50	106,00	-
	D	11,90	11,90	11,90	11,90	-
	E	11,90	11,90	11,90	11,90	-
13	A	214,00	219,50	224,50	229,50	236,50
	B	55,70	55,70	55,70	55,70	55,70
	C	101,75	104,50	107,00	109,50	113,00
	D	11,90	11,90	11,90	11,90	11,90
	E	11,90	11,90	11,90	11,90	11,90

Available flanges and shafts for GR28 Flange ed alberi disponibili per GR28

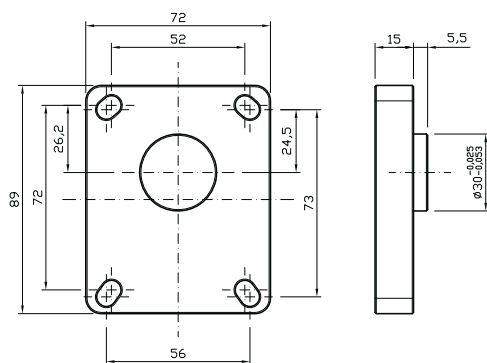

Type flange 1C3 / Flangia tipo 1C3

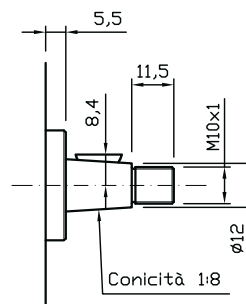

Type shaft 1C3 / Albero tipo 1C3
Max torque / Coppia max: 100 Nm

* Standard multiple pumps are delivered with both stages in fluid communication. When placing an order, it is necessary to specify if the two stages will handle different kinds of fluids or fluids coming from more than one reservoir. / Le pompe multiple sono consegnate con entrambi gli stadi in comunicazione di fluido. In fase di ordine, occorre specificare se la pompa multipla utilizza oli differenti sui diversi stadi o provenienti da più di un serbatoio.

GR33 & GR38 - Groups 2 tandem pumps*

GR33

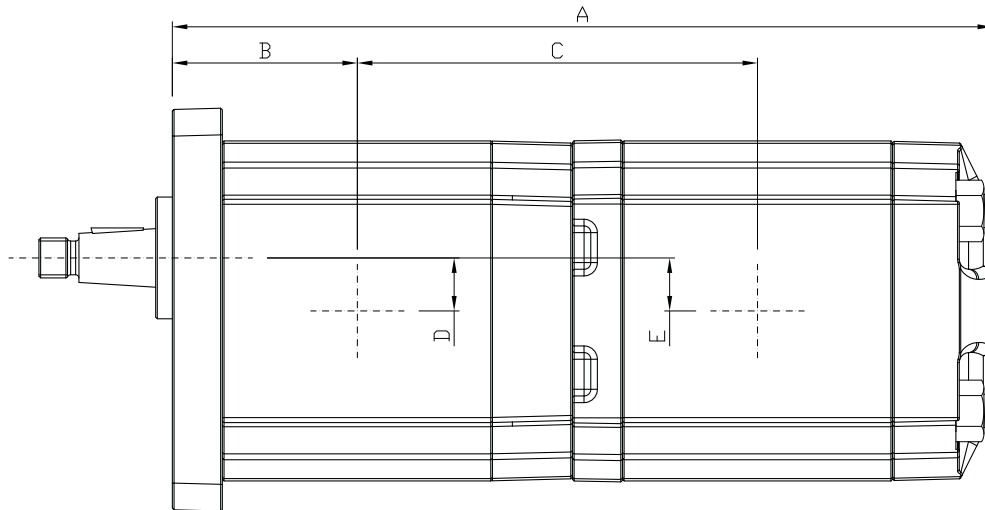

GR33 + GR28			2°				
			4	6	8	10	13
1°	10	A	216,50	222,00	227,00	232,00	239,00
		B	53,75	53,75	53,75	53,75	53,75
		C	16,25	109,00	111,50	114,00	117,50
		D	13,75	13,75	13,75	13,75	13,75
		E	11,90	11,90	11,90	11,90	11,90
	13	A	221,4	226,90	231,90	236,90	243,90
		B	56,20	56,20	56,20	56,20	56,20
		C	108,70	111,45	113,95	116,45	119,95
		D	13,75	13,75	13,75	13,75	13,75
		E	11,90	11,90	11,90	11,90	11,90
	15	A	226,40	231,90	236,90	241,90	248,90
		B	58,70	58,70	58,70	58,70	58,70
		C	111,20	113,95	116,45	118,95	122,45
		D	13,75	13,75	13,75	13,75	13,75
		E	11,90	11,90	11,90	11,90	11,90
	18	A	232,2	237,70	242,70	247,70	254,70
		B	61,60	61,60	61,60	61,60	61,60
		C	114,10	116,85	119,35	121,85	125,35
		D	13,75	13,75	13,75	13,75	13,75
		E	11,90	11,90	11,90	11,90	11,90

GR33 + GR33			2°			
			10	13	15	18
1°	10	A	236,00	-	-	-
		B	53,75	-	-	-
		C	113,50	-	-	-
		D	13,75	-	-	-
		E	13,75	-	-	-

GR33 + GR33			2°			
			10	13	15	18
	13	A	240,90	245,80	-	-
		B	56,20	56,20	-	-
		C	115,95	118,40	-	-
		D	13,75	13,75	-	-
		E	13,75	13,75	-	-
	15	A	245,90	250,80	255,80	-
		B	58,70	58,70	58,70	-
		C	118,45	120,90	123,40	-
		D	13,75	13,75	13,75	-
		E	13,75	13,75	13,75	-
	18	A	251,70	256,60	261,60	267,40
		B	61,60	61,60	61,60	61,60
		C	121,35	123,80	126,30	129,20
		D	13,75	13,75	13,75	13,75
		E	13,75	13,75	13,75	13,75

Available flanges and shafts for GR33
Flange ed alberi disponibili per GR33

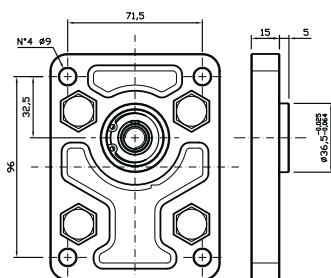

Type flange 2C4
 Flangia tipo 2C4

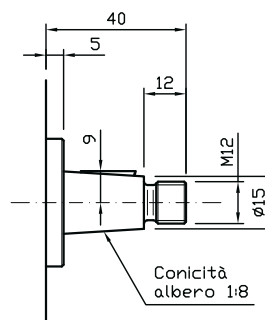

Type shaft 2C4
 Albero tipo 2C4
 Max torque / Coppia max: 210 Nm

* Standard multiple pumps are delivered with both stages in fluid communication. When placing an order, it is necessary to specify if the two stages will handle different kinds of fluids or fluids coming from more than one reservoir. / Le pompe multiple sono consegnate con entrambi gli stadi in comunicazione di fluido. In fase di ordine, occorre specificare se la pompa multipla utilizza oli differenti sui diversi stadi o provenienti da più di un serbatoio.

GR38 + GR28			2°				
			4	6	8	10	13
1°	16	A	191,50	228,50	233,50	238,50	245,50
		B	44,50	55,50	55,50	55,50	55,50
		C	90,50	113,75	116,25	118,75	122,25
		D	11,90	15,90	15,90	15,90	15,90
		E	11,90	11,90	11,90	11,90	11,90
	18	A	226,00	231,50	236,50	241,50	248,50
		B	57,00	57,00	57,00	57,00	57,00
		C	112,50	115,25	117,75	120,25	123,75
		D	15,90	15,90	15,90	15,90	15,90
		E	11,90	11,90	11,90	11,90	11,90
	20	A	229,00	234,50	239,50	244,50	251,50
		B	58,50	58,50	58,50	58,50	58,50
		C	114,00	116,75	119,25	121,75	125,25
		D	15,90	15,90	15,90	15,90	15,90
		E	11,90	11,90	11,90	11,90	11,90
	22	A	232,00	237,50	242,50	247,5	254,50
		B	60,00	60,00	60,00	60,00	60,00
		C	115,50	118,25	120,75	123,25	126,75
		D	15,90	15,90	15,90	15,90	15,90
		E	11,90	11,90	11,90	11,90	11,90
	25	A	236,50	242,00	247,00	252,00	259,00
		B	62,25	62,25	62,25	62,25	62,25
		C	117,75	120,50	123,00	125,50	129,00
		D	15,90	15,90	15,90	15,90	15,90
		E	11,90	11,90	11,90	11,90	11,90
28	A	241,00	246,50	251,50	256,50	263,50	
	B	64,50	64,50	64,50	64,50	64,50	
	C	120,00	122,75	125,25	127,75	131,25	
	D	15,90	15,90	15,90	15,90	15,90	
	E	11,90	11,90	11,90	11,90	11,90	

GR38 + GR33			2°			
			10	13	15	18
1°	16	A	242,50	247,40	252,40	258,20
		B	55,50	55,50	55,50	55,50
		C	118,25	120,70	123,20	126,10
		D	15,90	15,90	15,90	15,90
		E	13,75	13,75	13,75	13,75

GR38 + GR33			2°			
			10	13	15	18
	18	A	245,50	250,40	255,40	261,20
		B	57,00	57,00	57,00	57,00
		C	119,75	122,20	124,70	127,60
		D	15,90	15,90	15,90	15,90
		E	13,75	13,75	13,75	13,75
	20	A	248,50	253,40	258,40	264,20
		B	58,50	58,50	58,50	58,50
		C	121,25	123,70	126,20	129,10
		D	15,90	15,90	15,90	15,90
		E	13,75	13,75	13,75	13,75
	22	A	251,50	256,40	261,40	267,20
		B	60,00	60,00	60,00	60,00
		C	122,75	125,20	127,70	130,60
		D	15,90	15,90	15,90	15,90
		E	13,75	13,75	13,75	13,75
	25	A	2560	260,90	265,90	271,70
		B	62,25	62,25	62,25	62,25
		C	1250	127,45	129,95	132,85
		D	15,90	15,90	15,90	15,90
		E	13,75	13,75	13,75	13,75
28	A	260,50	265,4	270,40	276,20	
	B	64,50	64,50	64,50	64,50	
	C	127,25	129,70	132,20	135,1 0	
	D	15,90	15,90	15,90	15,90	
	E	13,75	13,75	13,75	13,75	

GR38 + GR38			2°					
			16	18	20	22	25	28
1°	16	A	246,00	-	-	-	-	-
		B	55,50	-	-	-	-	-
		C	120,00	-	-	-	-	-
		D	15,90	-	-	-	-	-
		E	15,90	-	-	-	-	-
	18	A	249,00	252,00	-	-	-	-
		B	57,00	57,00	-	-	-	-
		C	121,50	123,00	-	-	-	-
		D	15,90	15,90	-	-	-	-
		E	15,90	15,90	-	-	-	-

GR38 + GR38			2°					
			16	18	20	22	25	28
1°	20	A	252,00	255,00	258,00	-	-	-
		B	58,50	58,50	58,50	-	-	-
		C	123,00	124,50	126,00	-	-	-
		D	15,90	15,90	15,90	-	-	-
		E	15,90	15,90	15,90	-	-	-
	22	A	255,00	258,00	261,00	264,00	-	-
		B	60,00	60,00	60,00	60,00	-	-
		C	124,50	126,00	127,50	129,00	-	-
		D	15,90	15,90	15,90	15,90	-	-
		E	15,90	15,90	15,90	15,90	-	-
	25	A	259,50	262,50	265,50	268,50	273,00	-
		B	62,25	62,25	62,25	62,25	62,25	-
		C	126,75	128,25	129,75	131,25	133,50	-
		D	15,90	15,90	15,90	15,90	15,90	-
		E	15,90	15,90	15,90	15,90	15,90	-
	28	A	264,00	267,00	270,00	273,00	277,50	282,00
		B	64,50	64,50	64,50	64,50	64,50	64,50
		C	129,00	130,50	132,00	133,50	135,75	138,00
		D	15,90	15,90	15,90	15,90	15,90	15,90
		E	15,90	15,90	15,90	15,90	15,90	15,90

Available flanges and shafts for GR38 Flange ed alberi disponibili per GR38

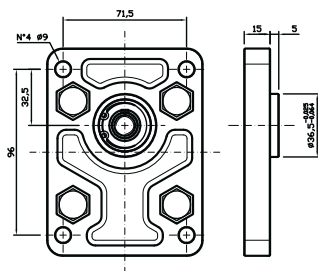

Type flange 2C4
Flangia tipo 2C4

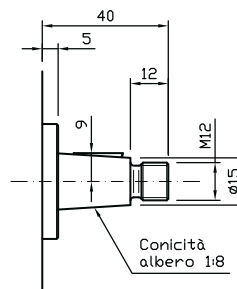

Type shaft 2C4
Albero tipo 2C4
Max torque / Coppia max: 210 Nm

* Standard multiple pumps are delivered with both stages in fluid communication. When placing an order, it is necessary to specify if the two stages will handle different kinds of fluids or fluids coming from more than one reservoir. / Le pompe multiple sono consegnate con entrambi gli stadi in comunicazione di fluido. In fase di ordine, occorre specificare se la pompa multipla utilizza oli differenti sui diversi stadi o provenienti da più di un serbatoio.

GR47 - Group 3 tandem pumps

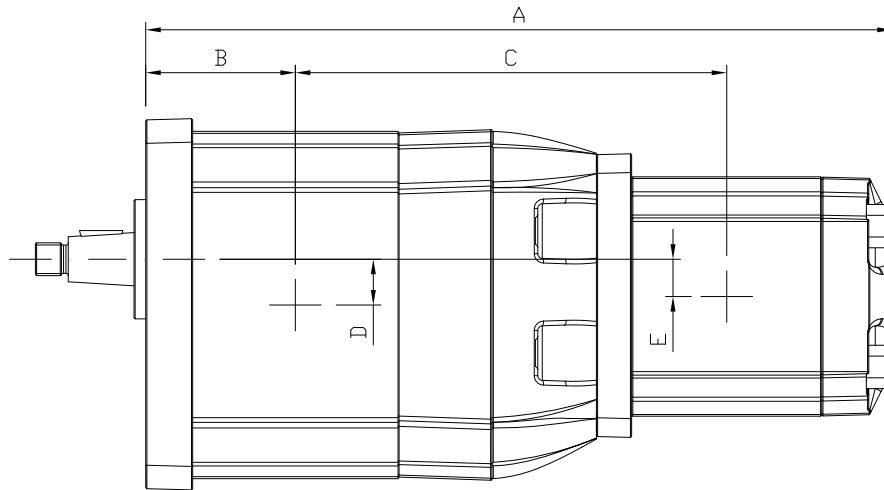

GR47 + GR28		2°					
		4	6	8	10	13	
1°	28	A	292,00	297,50	302,50	307,50	314,40
		B	67,50	67,50	67,50	67,50	67,50
		C	168,00	170,75	173,25	175,75	179,25
		D	19,50	19,50	19,50	19,50	19,50
		E	11,90	11,90	11,90	11,90	11,90
	32	A	296,00	301,50	306,50	311,50	318,40
		B	69,50	69,50	69,50	69,50	69,50
		C	170,00	172,75	175,25	177,75	181,25
		D	19,50	19,50	19,50	19,50	19,50
		E	11,90	11,90	11,90	11,90	11,90
	36	A	300,00	305,50	310,50	315,50	322,40
		B	71,50	71,50	71,50	71,50	71,50
		C	136,00	138,75	141,25	143,75	147,20
		D	19,50	19,50	19,50	19,50	19,50
		E	11,90	11,90	11,90	11,90	11,90
	40	A	304,00	309,50	314,50	319,50	326,40
		B	73,50	73,50	73,50	73,50	73,50
		C	174,00	176,75	179,25	181,75	185,25
		D	19,50	19,50	19,50	19,50	19,50
		E	11,90	11,90	11,90	11,90	11,90
45	A	308,50	314,00	319,00	324,00	330,90	
	B	75,75	75,75	75,75	75,75	75,75	
	C	140,25	143,00	145,50	148,00	151,45	
	D	19,50	19,50	19,50	19,50	19,50	
	E	11,90	11,90	11,90	11,90	11,90	
50	A	313,50	319,00	324,00	329,00	335,90	
	B	78,25	78,25	78,25	78,25	78,25	
	C	178,75	181,50	184,00	186,50	190,00	
	D	19,50	19,50	19,50	19,50	19,50	
	E	11,90	11,90	11,90	11,90	11,90	

GR47 + GR33			2°			
			10	13	15	18
1°	28	A	322,00	326,90	331,90	337,70
		B	67,50	67,50	67,50	67,50
		C	185,25	188,20	190,70	193,60
		D	19,50	19,50	19,50	19,50
		E	13,75	13,75	13,75	13,75
	32	A	326,00	330,90	335,90	341,70
		B	69,50	69,50	69,50	69,50
		C	187,25	190,20	192,70	195,60
		D	19,50	19,50	19,50	19,50
		E	13,75	13,75	13,75	13,75
	36	A	330,00	334,90	339,90	345,70
		B	71,50	71,50	71,50	71,50
		C	189,75	192,20	194,70	197,60
		D	19,50	19,50	19,50	19,50
		E	13,75	13,75	13,75	13,75
	40	A	334,00	338,90	343,90	349,70
		B	73,50	73,50	73,50	73,50
		C	191,75	194,20	196,70	199,60
		D	19,50	19,50	19,50	19,50
		E	13,75	13,75	13,75	13,75
	45	A	338,50	343,40	348,40	354,20
		B	75,75	75,75	75,75	75,75
		C	194,00	196,45	198,95	201,85
		D	19,50	19,50	19,50	19,50
		E	13,75	13,75	13,75	13,75
50	A	343,50	348,40	353,40	359,20	
	B	78,25	78,25	78,25	78,25	
	C	196,50	198,95	201,45	204,35	
	D	19,50	19,50	19,50	19,50	
	E	13,75	13,75	13,75	13,75	

GR47 + GR38			2°					
			16	18	20	22	25	28
1°	28	A	325,50	328,50	331,50	334,50	339,00	343,50
		B	67,50	67,50	67,50	67,50	67,50	67,50
		C	187,50	189,00	190,50	192,00	194,25	196,50
		D	19,50	19,50	19,50	19,50	19,50	19,50
		E	15,90	15,90	15,90	15,90	15,90	15,90
	32	A	329,50	332,50	335,50	338,50	343,00	347,50
		B	69,50	69,50	69,50	69,50	69,50	69,50
		C	189,50	191,00	192,50	194,00	196,25	198,50
		D	19,50	19,50	19,50	19,50	19,50	19,50
		E	15,90	15,90	15,90	15,90	15,90	15,90

GR47 + GR38			2°					
			16	18	20	22	25	28
	36	A	333,50	336,50	339,50	342,50	347,00	351,50
		B	71,50	71,50	71,50	71,50	71,50	71,50
		C	191,50	193,00	194,50	196,00	198,25	200,50
		D	19,50	19,50	19,50	19,50	19,50	19,50
		E	15,90	15,90	15,90	15,90	15,90	15,90
	40	A	337,50	340,50	343,50	346,50	351,00	355,50
		B	73,50	73,50	73,50	73,50	73,50	73,50
		C	193,50	195,00	196,50	198,00	200,25	202,50
		D	19,50	19,50	19,50	19,50	19,50	19,50
		E	15,90	15,90	15,90	15,90	15,90	15,90
	45	A	342,00	345,00	348,00	351,00	355,50	360,00
		B	75,75	75,75	75,75	75,75	75,75	75,75
		C	195,75	197,25	198,75	200,25	202,50	204,75
		D	19,50	19,50	19,50	19,50	19,50	19,50
		E	15,90	15,90	15,90	15,90	15,90	15,90
	50	A	347,00	350,00	353,00	356,00	360,5	365,00
		B	78,25	78,25	78,25	78,25	78,25	78,25
		C	198,25	199,75	201,25	202,75	205,00	207,25
		D	19,50	19,50	19,50	19,50	19,50	19,50
		E	15,90	15,90	15,90	15,90	15,90	15,90

GR47 + GR47			2°					
			28	32	36	40	45	50
1°	28	A	351,00	-	-	-	-	-
		B	67,50	-	-	-	-	-
		C	201,00	-	-	-	-	-
		D	19,50	-	-	-	-	-
		E	19,50	-	-	-	-	-
	32	A	356,50	360,50	-	-	-	-
		B	69,50	69,50	-	-	-	-
		C	203,00	205,00	-	-	-	-
		D	19,50	19,50	-	-	-	-
		E	19,50	19,50	-	-	-	-
	36	A	360,50	364,50	368,50	-	-	-
		B	71,50	71,50	71,50	-	-	-
		C	205,00	207,00	209,00	-	-	-
		D	19,50	19,50	19,50	-	-	-
		E	19,50	19,50	19,50	-	-	-

GR47 + GR47			2°					
			28	32	36	40	45	50
40	A	364,50	368,50	372,50	376,50	-	-	
	B	73,50	73,50	73,50	73,50	-	-	
	C	207,00	209,00	211,00	213,00	-	-	
	D	19,50	19,50	19,50	19,50	-	-	
	E	19,50	19,50	19,50	19,50	-	-	
45	A	369,00	373,00	377,00	381,00	385,50	-	
	B	75,75	75,75	75,75	75,75	75,75	-	
	C	209,25	211,25	213,25	215,25	217,50	-	
	D	19,50	19,50	19,50	19,50	19,50	-	
	E	19,50	19,50	19,50	19,50	19,50	-	
50	A	374,00	378,00	382,00	386,00	390,50	395,50	
	B	78,25	78,25	78,25	78,25	78,25	78,25	
	C	211,75	213,75	215,75	217,75	220,00	222,50	
	D	19,50	19,50	19,50	19,50	19,50	19,50	
	E	19,50	19,50	19,50	19,50	19,50	19,50	

Available flanges and shafts for GR47
Flange ed alberi disponibili per GR47

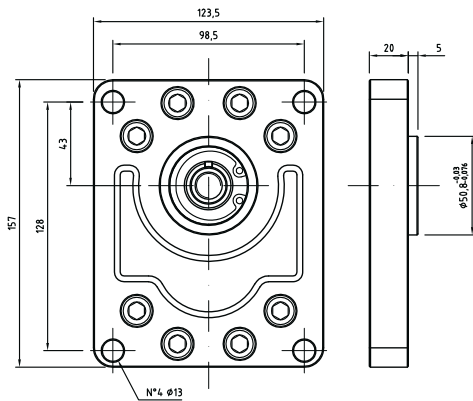

Type flange 3-C9
 Flangia tipo 3-C9

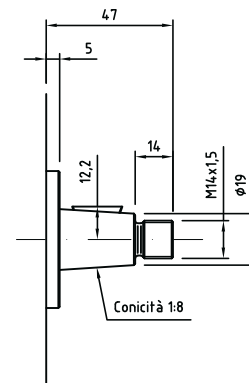

Type shaft 3-C9
 Albero tipo 3-C9
 Max torque / Coppia max: 320 Nm

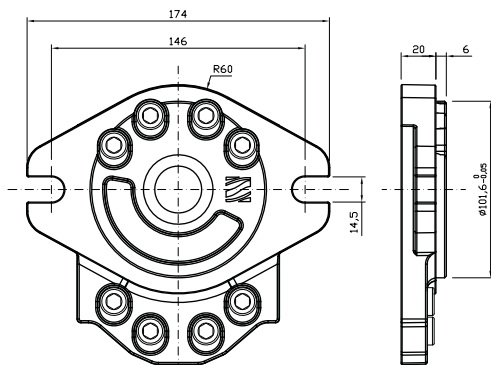

Type flange SAEB-T13
 Flangia tipo SAEB-T13

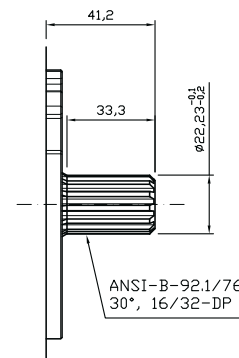

Type shaft SAEB-T13
 Albero tipo SAEB-T13
 Max torque / Coppia max: 600 Nm

GR55 - Group 3 tandem pumps

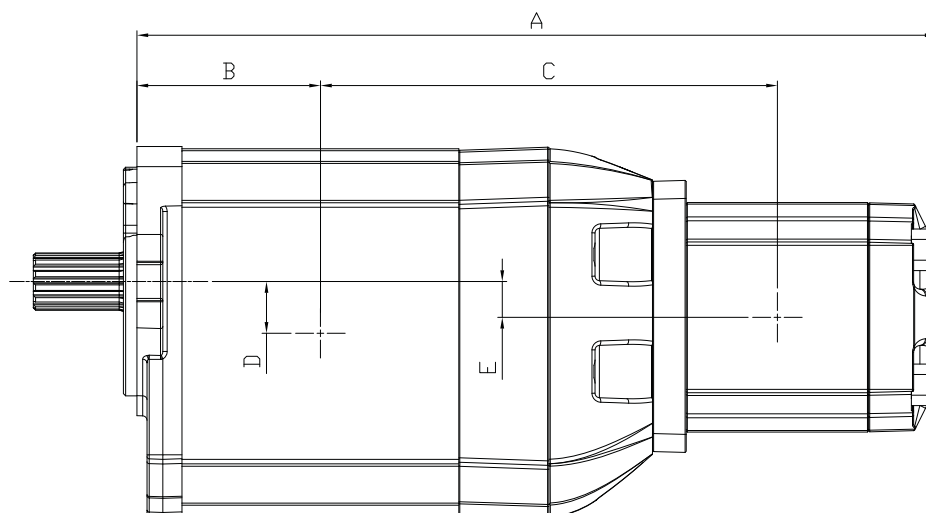

GR55 + GR28			2°				
			4	6	8	10	13
1°	50	A	323,00	328,50	333,50	338,50	345,40
		B	81,50	81,50	81,50	81,50	81,50
		C	185,00	187,75	190,25	192,75	196,25
		D	23,00	23,00	23,00	23,00	23,00
		E	11,90	11,90	11,90	11,90	11,90
	63	A	332,00	337,50	342,50	347,50	354,40
		B	86,00	86,00	86,00	86,00	86,00
		C	246,00	251,50	256,50	261,50	268,50
		D	23,00	23,00	23,00	23,00	23,00
		E	11,90	11,90	11,90	11,90	11,90
	75	A	340,00	345,50	350,50	355,50	362,40
		B	90,00	90,00	90,00	90,00	90,00
		C	193,50	196,25	198,75	201,25	204,75
		D	23,00	23,00	23,00	23,00	23,00
		E	11,90	11,90	11,90	11,90	11,90
	90	A	351,00	356,50	361,50	366,50	373,40
		B	95,50	95,50	95,50	95,50	95,50
		C	199,00	201,75	204,25	206,75	210,25
		D	23,00	23,00	23,00	23,00	23,00
		E	11,90	11,90	11,90	11,90	11,90

GR55 + GR33			2°			
			10	13	15	18
1°	50	A	351,50	356,40	361,40	367,20
		B	81,50	81,50	81,50	81,50
		C	201,25	203,70	206,20	209,10
		D	23,00	23,00	23,00	23,00
		E	13,75	13,75	13,75	13,75
	63	A	360,50	365,40	370,40	376,20
		B	86,00	86,00	86,00	86,00
		C	274,50	279,40	284,40	290,20
		D	23,00	23,00	23,00	23,00
		E	13,75	13,75	13,75	13,75
	75	A	368,50	373,40	378,40	384,20
		B	90,00	90,00	90,00	90,00
		C	209,75	212,20	214,70	217,60
		D	23,00	23,00	23,00	23,00
		E	13,75	13,75	13,75	13,75
	90	A	379,50	384,40	389,40	395,20
		B	95,50	95,50	95,50	95,50
		C	215,25	217,70	220,0	223,10
		D	23,00	23,00	23,00	23,00
		E	13,75	13,75	13,75	13,75

GR55 + GR33			2°			
			10	13	15	18
1°	50	A	351,50	356,40	361,40	367,20
		B	81,50	81,50	81,50	81,50
		C	201,25	203,70	206,20	209,10
		D	23,00	23,00	23,00	23,00
		E	13,75	13,75	13,75	13,75
	63	A	360,50	365,40	370,40	376,20
		B	86,00	86,00	86,00	86,00
		C	274,50	279,40	284,40	290,20
		D	23,00	23,00	23,00	23,00
		E	13,75	13,75	13,75	13,75
	75	A	368,50	373,40	378,40	384,20
		B	90,00	90,00	90,00	90,00
		C	209,75	212,20	214,70	217,60
		D	23,00	23,00	23,00	23,00
		E	13,75	13,75	13,75	13,75
	90	A	379,50	384,40	389,40	395,20
		B	95,50	95,50	95,50	95,50
		C	215,25	217,70	220,20	223,10
		D	23,00	23,00	23,00	23,00
		E	13,75	13,75	13,75	13,75

GR55 + GR38			2°					
			16	18	20	22	25	28
1°	50	A	355,00	358,00	361,00	364,00	368,50	373,00
		B	81,50	81,50	81,50	81,50	81,50	81,50
		C	203,00	204,50	206,00	207,50	209,75	212,00
		D	23,00	23,00	23,00	23,00	23,00	23,00
		E	15,90	15,90	15,90	15,90	15,90	15,90
	63	A	364,00	367,00	370,00	373,00	377,50	382,00
		B	86,00	86,00	86,00	86,00	86,00	86,00
		C	278,00	281,00	284,00	287,00	291,50	296,00
		D	23,00	23,00	23,00	23,00	23,00	23,00
		E	15,90	15,90	15,90	15,90	15,90	15,90
	75	A	372,00	375,00	378,00	381,00	385,50	390,00
		B	90,00	90,00	90,00	90,00	90,00	90,00
		C	211,50	213,00	214,50	216,00	218,25	220,50
		D	23,00	23,00	23,00	23,00	23,00	23,00
		E	15,90	15,90	15,90	15,90	15,90	15,90
	90	A	383,00	386,00	389,00	392,00	396,50	401,00
		B	95,50	95,50	95,50	95,50	95,50	95,50
		C	217,00	218,50	220,00	221,50	223,75	226,00
		D	23,00	23,00	23,00	23,00	23,00	23,00
		E	15,90	15,90	15,90	15,90	15,90	15,90

GR55 + GR47			2°					
			28	32	36	40	45	50
1°	50	A	387,00	391,00	395,00	400,50	403,50	408,50
		B	81,50	81,50	81,50	81,50	81,50	81,50
		C	223,00	225,00	227,00	229,00	231,25	233,75
		D	23,00	23,00	23,00	23,00	23,00	23,00
		E	19,50	19,50	19,50	19,50	19,50	19,50
	63	A	396,00	400,00	404,00	408,00	412,50	417,50
		B	86,00	86,00	86,00	86,00	86,00	86,00
		C	310,00	314,00	318,00	322,00	326,50	331,50
		D	23,00	23,00	23,00	23,00	23,00	23,00
		E	19,50	19,50	19,50	19,50	19,50	19,50
	75	A	404,00	408,00	412,00	416,00	420,50	425,50
		B	90,00	90,00	90,00	90,00	90,00	90,00
		C	231,50	233,50	235,50	237,50	239,75	242,25
		D	23,00	23,00	23,00	23,00	23,00	23,00
		E	19,50	19,50	19,50	19,50	19,50	19,50
	90	A	415,00	418,00	423,00	427,00	431,50	436,50
		B	95,50	95,50	95,50	95,50	95,50	95,50
		C	237,00	239,00	241,00	243,00	245,25	247,75
		D	23,00	23,00	23,00	23,00	23,00	23,00
		E	19,50	19,50	19,50	19,50	19,50	19,50

GR55 + GR55			2°			
			50	63	75	90
1°	50	A	415,00	-	-	-
		B	81,50	-	-	-
		C	237,00	-	-	-
		D	23,00	-	-	-
		E	19,50	-	-	-
	63	A	424,00	433,00	-	-
		B	86,00	86,00	-	-
		C	338,00	347,00	-	-
		D	23,00	23,00	-	-
		E	19,50	19,50	-	-
	75	A	432,00	441,00	449,00	-
		B	90,00	90,00	90,00	-
		C	245,50	250,00	254,00	-
		D	23,00	23,00	23,00	-
		E	19,50	19,50	19,50	-
	90	A	443,00	452,00	460,00	471,00
		B	95,50	95,50	95,50	95,50
		C	251,00	255,50	259,50	265,00
		D	23,00	23,00	23,00	23,00
		E	19,50	19,50	19,50	19,50

Available flanges and shafts for GR55
Flange ed alberi disponibili per GR55

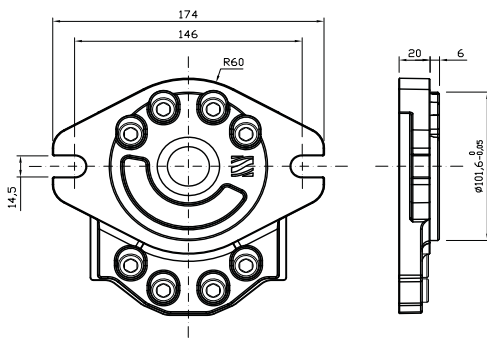

Type flange SAEB-T15
 Flangia tipo SAEB-T15

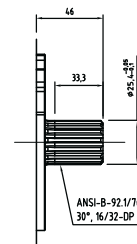

Type shaft SAEB-T15
 Albero tipo SAEB-T15
 Max torque / Coppia max: 700 Nm

GR72 - Group 4 tandem pumps

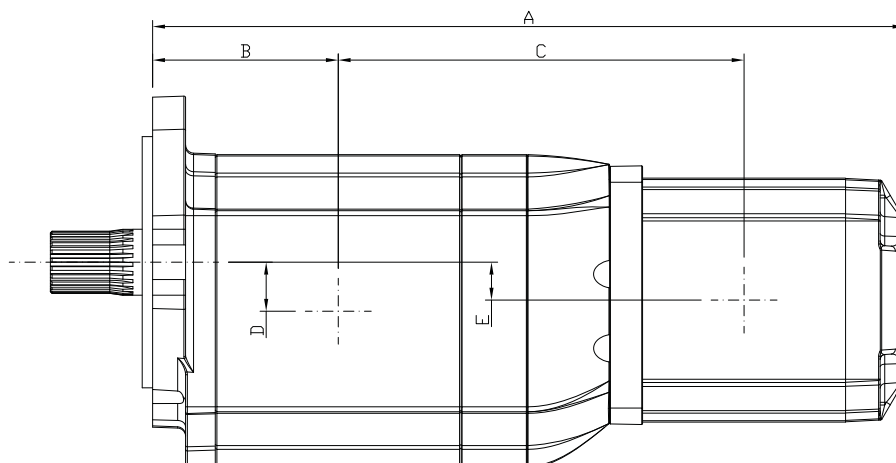

GR72 + GR47			2°					
			28	32	36	40	45	50
1°	94	A	440,00	444,00	448,00	452,00	456,50	461,50
		B	125,50	125,50	125,50	125,50	125,50	125,50
		C	232,00	234,00	236,00	238,00	240,25	242,75
		D	29,75	29,75	29,75	29,75	29,75	29,75
		E	19,50	19,50	19,50	19,50	19,50	19,50
	101	A	443,00	447,00	451,00	455,00	459,50	464,50
		B	127,00	127,00	127,00	127,00	127,00	127,00
		C	316,00	320,00	324,00	328,00	332,50	337,50
		D	29,75	29,75	29,75	29,75	29,75	29,75
		E	19,50	19,50	19,50	19,50	19,50	19,50
	125	A	453,00	457,00	461,00	465,00	469,50	474,50
		B	132,00	132,00	132,00	132,00	132,00	132,00
		C	238,50	240,50	242,50	244,50	246,75	249,25
		D	29,75	29,75	29,75	29,75	29,75	29,75
		E	19,50	19,50	19,50	19,50	19,50	19,50
	150	A	463,50	467,50	471,50	475,50	480,00	485,00
		B	137,25	137,25	137,25	137,25	137,25	137,25
		C	243,75	245,75	247,75	249,75	252,00	254,50
		D	29,75	29,75	29,75	29,75	29,75	29,75
		E	19,50	19,50	19,50	19,50	19,50	19,50
175	A	473,50	477,50	481,50	485,50	490,00	495,00	
	B	142,25	142,25	142,25	142,25	142,25	142,25	
	C	248,75	245,75	247,75	249,75	252,00	254,50	
	D	29,75	29,75	29,75	29,75	29,75	29,75	
	E	19,50	19,50	19,50	19,50	19,50	19,50	
200	A	484,00	488,00	492,00	496,00	500,50	505,50	
	B	147,50	147,50	147,50	147,50	147,50	147,50	
	C	254,00	256,00	258,00	260,00	262,25	264,75	
	D	29,75	29,75	29,75	29,75	29,75	29,75	
	E	19,50	19,50	19,50	19,50	19,50	19,50	

GR72 + GR55			2°			
			50	63	75	90
1°	94	A	468,00	477,00	485,00	496,00
		B	125,50	125,50	125,50	125,50
		C	246,00	250,50	254,50	260,00
		D	29,75	29,75	29,75	29,75
		E	19,50	19,50	19,50	19,50
	101	A	471,00	480,00	488,00	499,00
		B	127,00	127,00	127,00	127,00
		C	344,00	353,00	361,00	372,00
		D	29,75	29,75	29,75	29,75
		E	19,50	19,50	19,50	19,50
	125	A	481,00	490,00	498,00	509,00
		B	132,00	132,00	132,00	132,00
		C	252,50	257,00	261,00	266,50
		D	29,75	29,75	29,75	29,75
		E	19,50	19,50	19,50	19,50
	150	A	491,50	500,50	508,50	519,50
		B	137,25	137,25	137,25	137,25
		C	257,75	262,25	266,25	271,75
		D	29,75	29,75	29,75	29,75
		E	19,50	19,50	19,50	19,50
	175	A	501,50	510,50	518,50	529,50
		B	142,25	142,25	142,25	142,25
		C	262,75	267,25	271,25	276,75
		D	29,75	29,75	29,75	29,75
		E	19,50	19,50	19,50	19,50
200	A	512,00	521,00	529,00	540,00	
	B	147,50	147,50	147,50	147,50	
	C	268,00	272,50	276,50	282,00	
	D	29,75	29,75	29,75	29,75	
	E	19,50	19,50	19,50	19,50	

GR72 + GR72			2°					
			94	100	125	150	175	200
1°	94	A	556,50	-	-	-	-	-
		B	125,50	-	-	-	-	-
		C	311,50	-	-	-	-	-
		D	29,75	-	-	-	-	-
		E	29,75	-	-	-	-	-
	100	A	559,50	562,50	-	-	-	-
		B	127,00	127,00	-	-	-	-
		C	432,50	435,50	-	-	-	-
		D	29,75	29,75	-	-	-	-
		E	29,75	29,75	-	-	-	-

GR72 + GR72			2°					
			94	100	125	150	175	200
	125	A	569,50	572,50	582,50	-	-	-
		B	132,00	132,00	132,00	-	-	-
		C	318,00	319,50	324,50	-	-	-
		D	29,75	29,75	29,75	-	-	-
		E	29,75	29,75	29,75	-	-	-
	150	A	580,00	583,00	593,00	603,50	-	-
		B	137,25	137,25	137,25	137,25	-	-
		C	323,25	324,75	329,75	335,00	-	-
		D	29,75	29,75	29,75	29,75	-	-
		E	29,75	29,75	29,75	29,75	-	-
	175	A	590,00	593,00	603,00	613,50	623,50	-
		B	142,25	142,25	142,25	142,25	142,25	-
		C	328,25	329,75	334,75	340,00	345,00	-
		D	29,75	29,75	29,75	29,75	29,75	-
		E	29,75	29,75	29,75	29,75	29,75	-
	200	A	600,50	603,50	613,50	624,00	634,00	644,50
		B	147,50	147,50	147,50	147,50	147,50	147,50
		C	333,50	335,00	340,00	345,25	350,25	355,50
		D	29,75	29,75	29,75	29,75	29,75	29,75
		E	29,75	29,75	29,75	29,75	29,75	29,75

Available flanges and shafts for GR72
Flange ed alberi disponibili per GR72

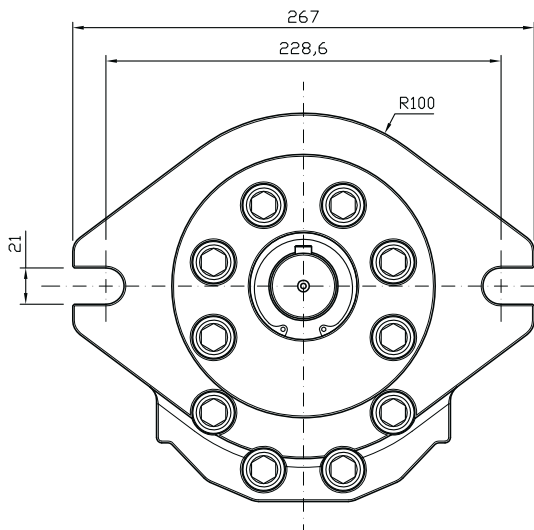

Type flange SAED-23T
 Flangia tipo SAED-23T

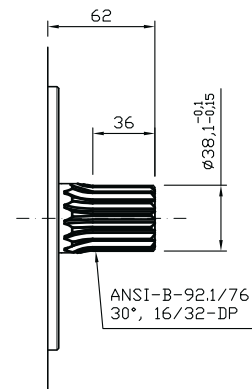
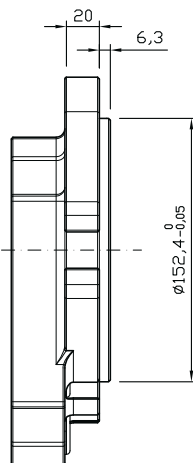

Type flange SAED-23T
 Flangia tipo SAED-23T
 Max torque / Coppia max: 1200 Nm

Settima full complement of products



SMT - high pressure industrial, lube and tool machines



SMT16B - cooling ,filtration and lube oil



SMT8B - compact cooling and filtration



SFO - shipyards diesel oil handling



SMAPI (API676) - wide range of marine and industrial applications



FOTP - high reliability boiler ignition/feeding marine application



SMTU - USA lift and freight elevators



SM - lift and freight elevators



Continuum® - high pressure, no noise fluid power applications



2VHL Continuum® - low pressure no noise lube services



FLOWMETERS - high pressure, high precision flow measurement



MAGNETIC COUPLING - sealless option for no medium leakage

Engineering and certification are a resource for our customers. If some certification is not available today, it could be available soon: ask Settima and we will answer.



SETTIMA

Settima, Italy

Headquarter, r&d and production

SETTIMA

USA
Warehouse

SETTIMA

ASIA Ltd.
Sales Office

Settima Meccanica Srl

Settima - 29020 Piacenza (Italia)

tel. +39 0523.3650

fax +39 0523.3650299

www.settima.it

info@settima.it

SETTIMA[®]
research & innovation. always