

1

SUPPORT WITH CYLINDRICAL SHAFT FOR PUMP GR.1

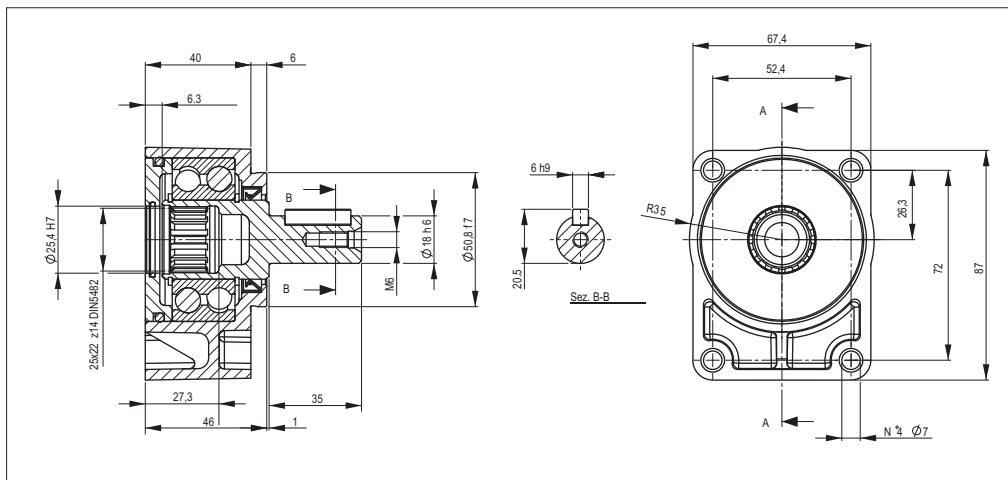

The SU/1-C, is suitable for driving Gr.1 hydraulic pumps and motors, with belts, chain or other transmission, in which heavy combined loads take place (axial and radial). The pump/motor Gr. 1, is directly flanged and connected by splined coupling (coupling to be ordered separately).

MAXIMUM LOAD ON THE SHAFT

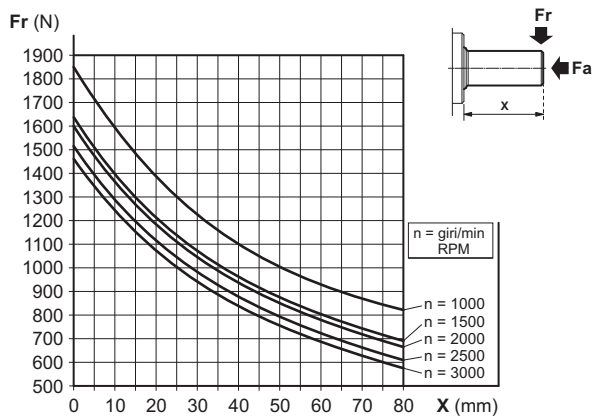

FEATURES

Minimum radial load (*)	Fr = 130 N
Radial load (*)	See graphic
Axial load (*)	Fa ≤ Fr • 0,8
Max. revolutions per minute	4000 RPM
Life (*)	3500 hours
Max. working temperature	70 °C
Grease quantity	10 ÷ 12 gr
Type of grease	DIN 51818 NLGI classe 2

(*) Nominal values calculated according to ISO 281. For more information, contact our technical department.

SPARE PARTS

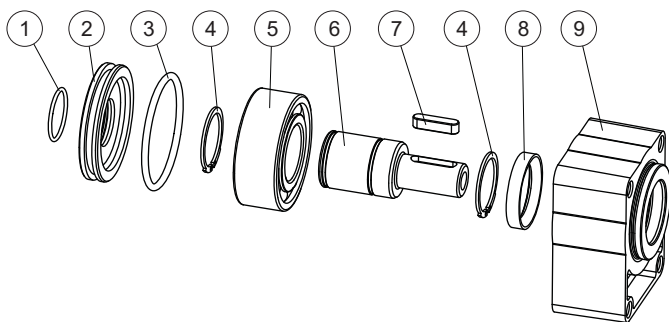

Ref.	Code	Description	Q.ty
1	Q25830030	O-Ring 25.12x1.78	1
2	39000500	Cover	1
3	Q25830215	O-Ring 55.56x3.53	1
4	Q27150300	Snap ring E30	2
5	44005200	Bearing 3206 30x62x23.8	1
6	34200400	Cylindrical shaft	1
7	Q27470206	Woodruff A6x6x25	1
8	44101800	Shaft seal 30x40x7	1
9	39000400	Body	1

ORDERING CODE

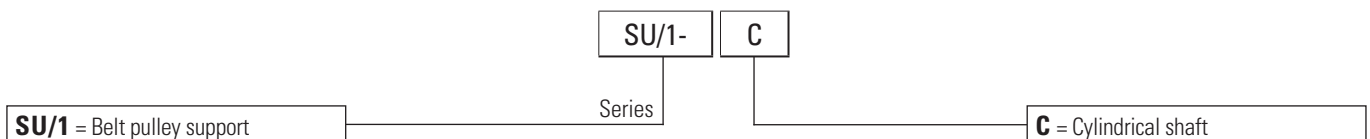

SUPPORT WITH CYLINDRICAL SHAFT FOR PUMP GR.2

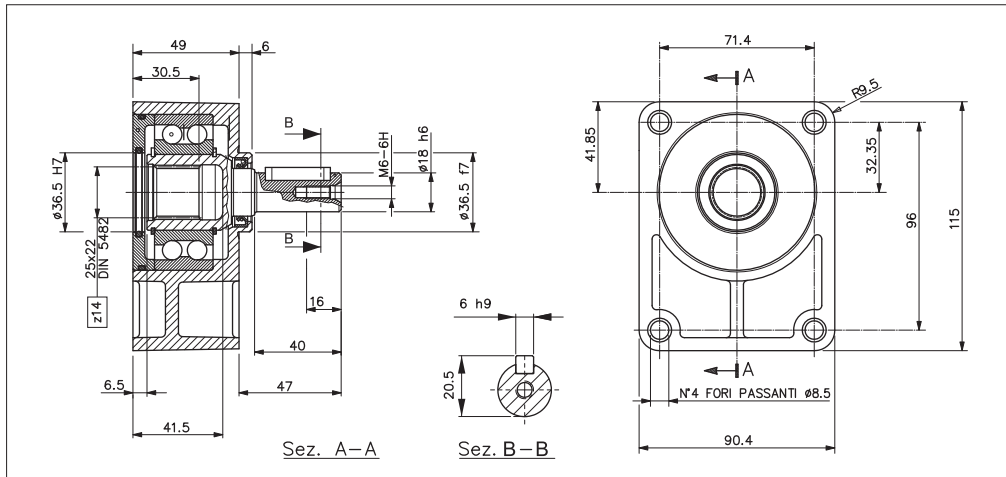

The SU/2-C, is suitable for driving Gr.2 hydraulic pumps and motors, with belts, chain or other transmission, in which heavy combined loads take place (axial and radial). The pump/motor Gr. 2, is directly flanged and connected by splined coupling (coupling to be ordered separately).

MAXIMUM LOAD ON THE SHAFT

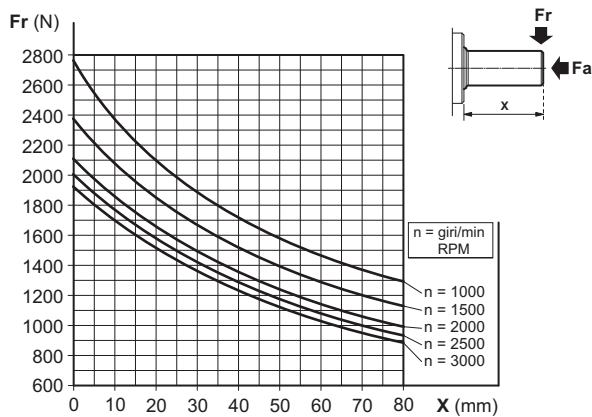

FEATURES

Minimum radial load (*)	Fr = 155 N
Radial load (*)	See graphic
Axial load (*)	Fa ≤ Fr • 0,8
Max. revolutions per minute	4000 RPM
Life (*)	3500 hours
Max. working temperature	70 °C
Grease quantity	16.5 ÷ 20.5 gr
Type of grease	DIN 51818 NLGI classe 2

(*) Nominal values calculated according to ISO 281. For more information, contact our technical department.

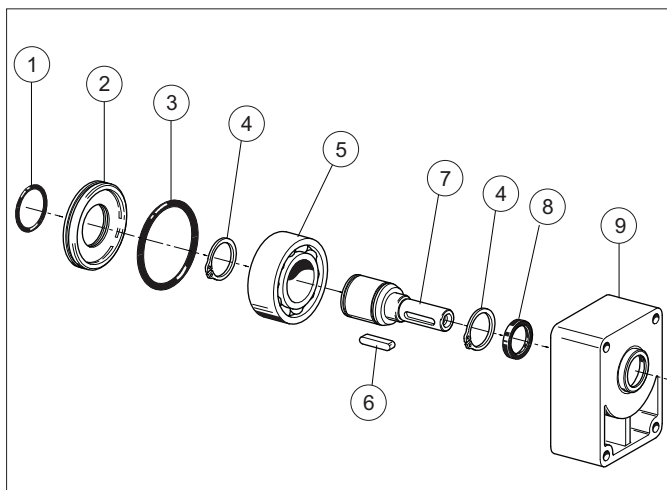

SPARE PARTS

Ref.	Code	Description	Q.ty
1	Q25830112	O-Ring 36,17x2,62	1
2	39003700	Cover	1
3	Q25830133	O-Ring 64,77x2,62	1
4	Q27150350	Snap ring E35	2
5	44005300	Bearing 3207 35x72x27	1
6	Q27470211	Woodruff A 6x6x30	1
7	34203300	Cylindrical shaft	1
8	44101900	Shaft seal 22x32x6	1
9	39003500	Body	1

ORDERING CODE

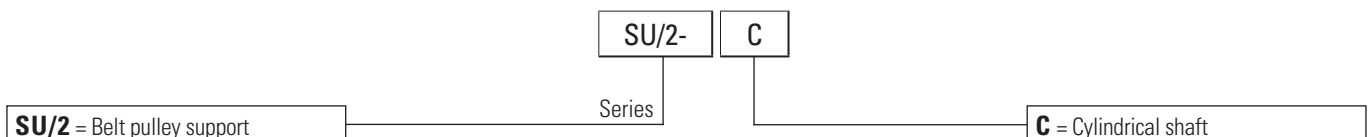

SUPPORT WITH CYLINDRICAL SHAFT FOR PUMP GR.3

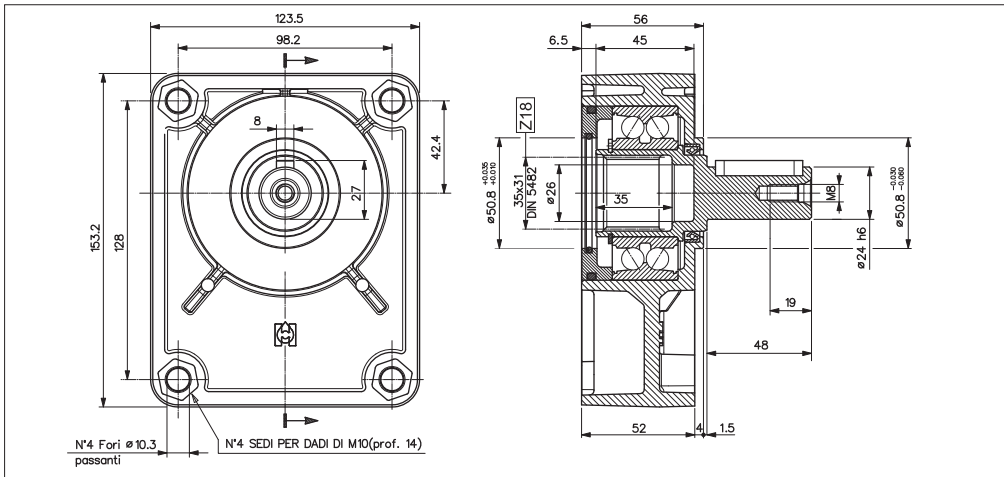

The SU/3-C, is suitable for driving Gr.3 hydraulic pumps and motors, with belts, chain or other transmission, in which heavy combined loads take place (axial and radial). The pump/motor Gr. 3, is directly flanged and connected by splined coupling (coupling to be ordered separately).

MAXIMUM LOAD ON THE SHAFT

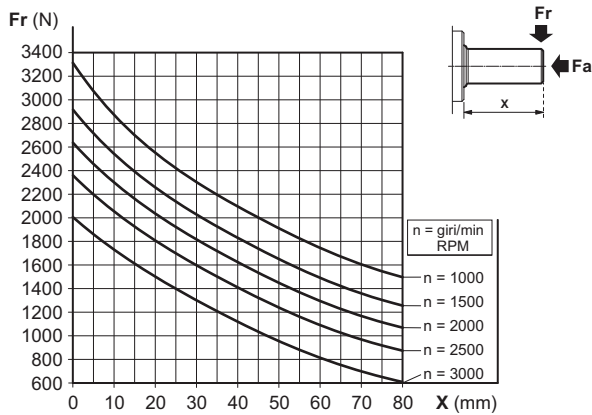

FEATURES

Minimum radial load (*)	Fr = 277 N
Radial load (*)	See graphic
Axial load (*)	Fa ≤ Fr • 0,8
Max. revolutions per minute	3500 RPM
Life (*)	3500 hours
Max. working temperature	70 °C
Grease quantity	19 ÷ 23.5 gr
Type of grease	DIN 51818 NLGI classe 2

(*) Nominal values calculated according to ISO 281. For more information, contact our technical department.

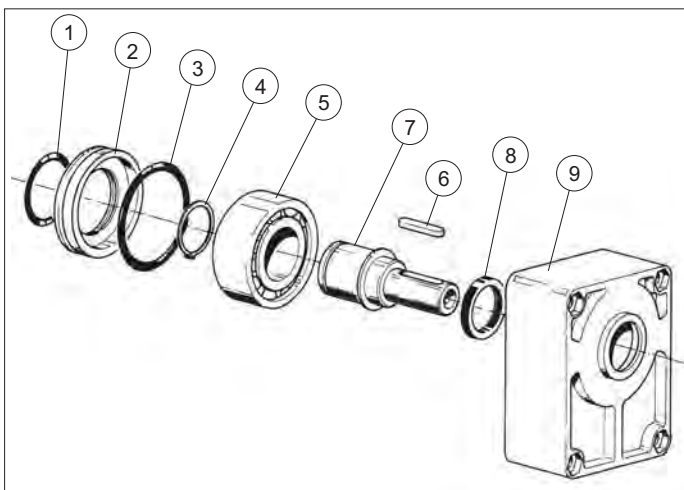

SPARE PARTS

Ref.	Code	Description	Q.ty
1	Q25830122	O-Ring 50.47x2.62	1
2	39025900	Cover	1
3	Q25830232	O-Ring 73.03x3.53	1
4	Q27150400	Snap ring E40	1
5	44005400	Bearing 3208 40x80x30.2	1
6	Q27470305	Woodruff A8x7x40	1
7	34215500	Cylindrical shaft	1
8	44104100	Shaft seal 45x35x7	1
9	39043700	Body	1

ORDERING CODE

