

ELECTROMAGNETIC CLUTCH - OIL LUBRICATION

3

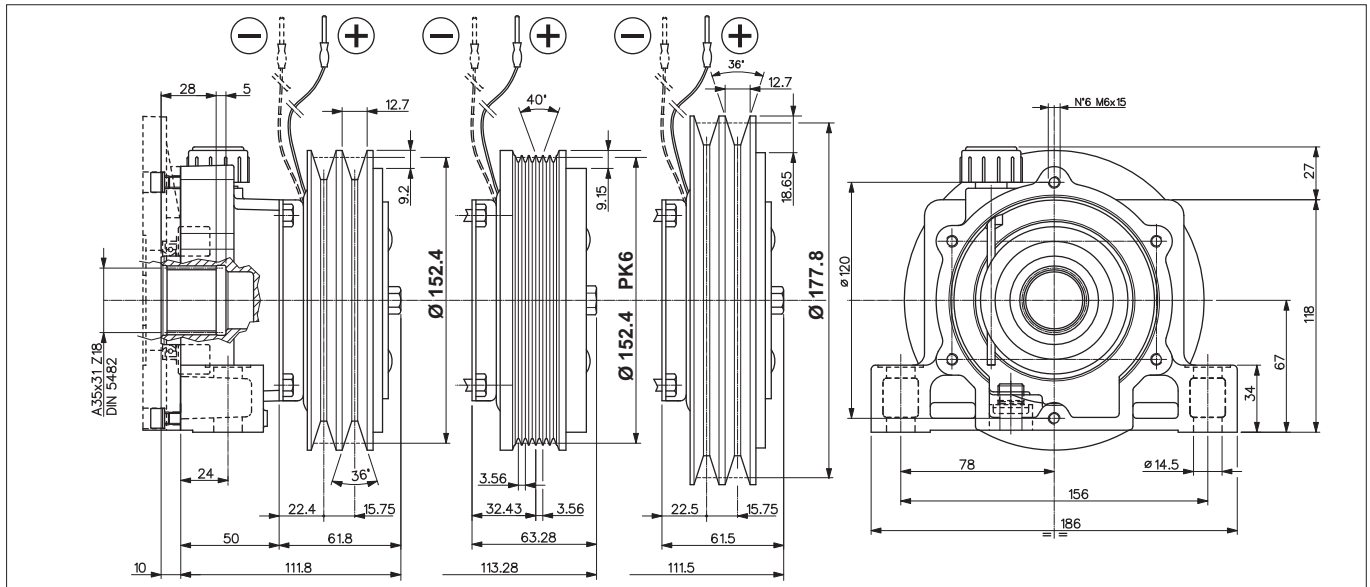

MAXIMUM LOAD ON THE SHAFT

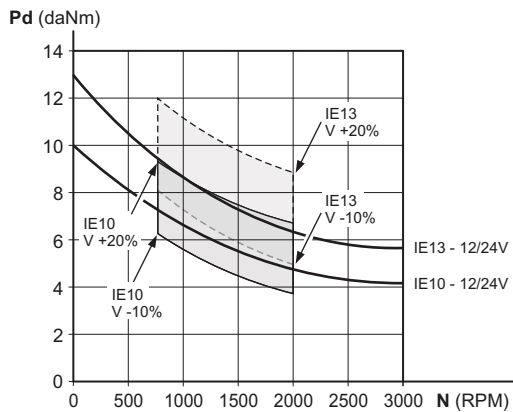

Approximate calculation of drive torque

$$P \text{ (daNm)} = c \cdot p \cdot 0,0017$$

$$P < P_d$$

where:

- p** = pump pressure in BAR
- c** = pump displacement in cc/revolution

from diagram:

- P<sub>d</sub>** = Max. torque allowed by the coupling in daNm
- n** = Motor rotation speed in rpm.

\* Input tension and operating temperature considerably influence the correct operation of the clutch. At temperatures above 70 °C the dynamic torque rating is reduced by 20%. To reach the maximum torque, run the clutch in through repeated working cycles (ON/OFF).

An electromagnetic clutch is a unit designed to convey movement to a UT hydraulic pump through an electrically controlled on/off pulley.

An electromagnetic clutch is composed of:

- an electromagnetic friction clutch (FE)
- an aluminium support (SU) with a conical (AT) and splined (UT) shaft mounted on oil-bath bearings.
- coupling to be ordered separately

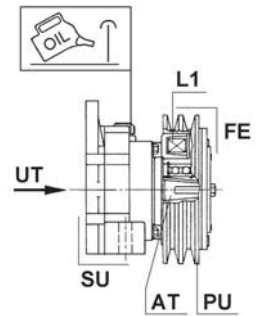

Description

This type of clutch exploits the force of attraction of an electromagnetic field generated by a solenoid that, after being energised (L1 in ON position), connects a pulley to a driving shaft.

The electromagnetic friction clutch is composed of two separate parts:

- a solenoid L1, mounted on the support;
- a pulley PU, mounted on the conical shaft AT.

Operations are as follows:

- under non operating conditions with L1 in OFF position: the pulley, driven by the "V" belt, turns idle on its own bearing,
- under operating conditions with L1 in ON position: the pulley, driven by the "V" belt, conveys movement to the shaft, then to the user UT.

FEATURES

RPM max	5000 RPM
Static nominal torque (*) (at 12/24V ± 0,5%)	10.2 daNm (pulley Ø152.4 - 2 races) 10.2 daNm (pulley Ø152.4 - 6 races) 12.2 daNm (pulley Ø177.8 - 2 races)
Power supply (*)	12 Vdc - 50W 24 Vdc - 60W
Rotation (pulley side)	CW
Working temperature	-10 °C ÷ +45 °C
Max working temperature coil (*)	100 °C
Oil quantity	0,07 lt.
Type of oil	Type: ISO 19378:2003 Viscosity: ISO VG 150 (ISO 3448:1992)
Oil replacement	After first 500hours then every 12 months

## ORDERING CODE

3

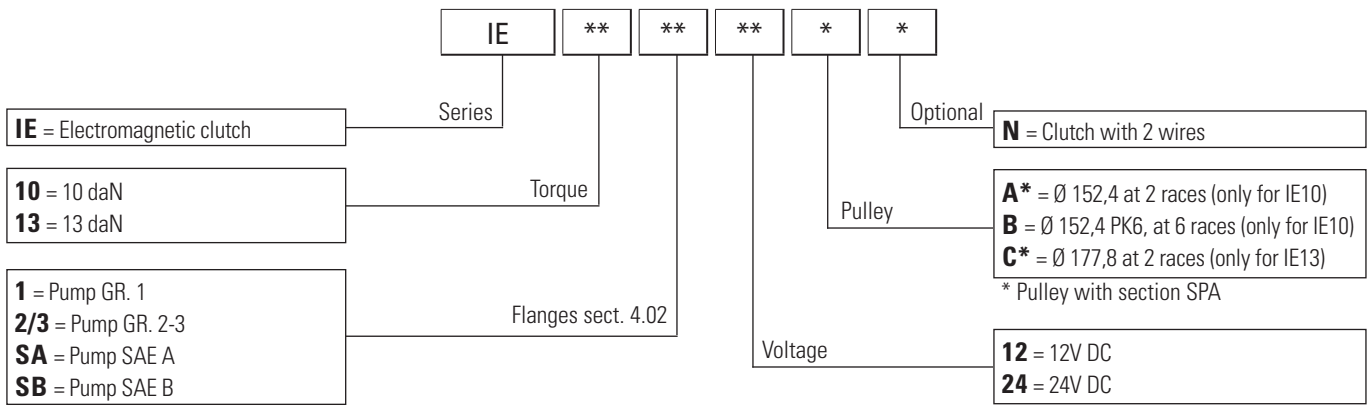

## SPARE PARTS

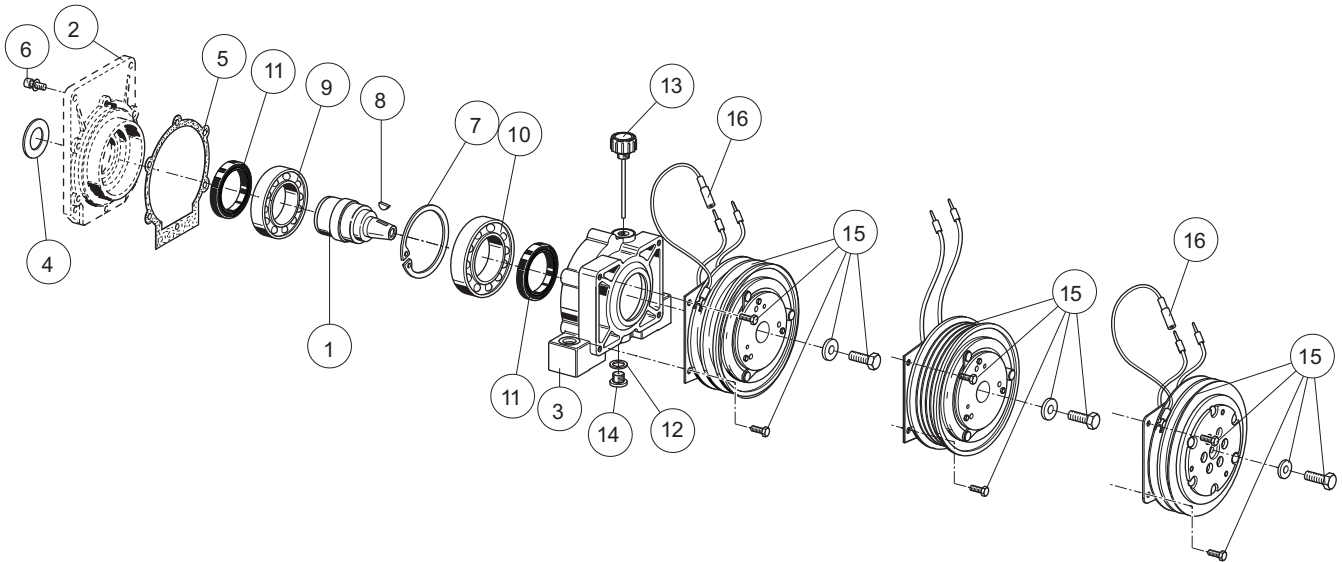

Ref.	Code	Q.ty			Description
		IE10..A..	IE10..B..	IE13..C..	
1	34241900	1	1	1	Shaft
2	—	1	1	1	Flanges (sect. 4.02)
3	39042700	1	1	1	Body
4	39101000	1	1	1	Flange D.66/25,4 (only for gr.1)
4	39101200	1	1	1	Flange D.66/36,5 (only for gr.2-3)
5	39204400	1	1	1	Gasket
6	40007300	6	6	6	Screw TCEI M6x20
7	Q27160080	1	1	1	Snap ring 180
8	Q27500070	1	1	1	Key 4x5 DIN 6888
9	44000300	1	1	1	Bearing 600945x75x16
10	44001200	1	1	1	Bearing 6010 50x80x16

Ref.	Code	Q.ty			Description
		IE10..A..	IE10..B..	IE13..C..	
11	44102200	2	2	2	Shaft seal 45x60x7
12	49000100	1	1	1	Washer nylon 13x19x1.5
13	49138600	1	1	1	Plug 1/4"
14	Q26622252	1	1	1	Plug TCEI G1/4
15	46004700	1	—	—	Clutch D.152.4 x 2 - 10 daNm - 12Vdc
	46004800	1	—	—	Clutch D.152.4 x 2 - 10 daNm - 24Vdc
	46008400	—	1	—	Clutch D.152.4 x 6 - 10 daNm - 12Vdc
	46008500	—	1	—	Clutch D.152.4 x 6 - 10 daNm - 24Vdc
	46005200	—	—	1	Clutch D.177.8 x 2 - 13 daNm - 12Vdc
	46008200	—	—	1	Clutch D.177.8 x 2 - 13 daNm - 24Vdc
16	26000005	1	—	1	Wire L=65

**ELECTROMAGNETIC CLUTCH - GREASE LUBRICATION**

3

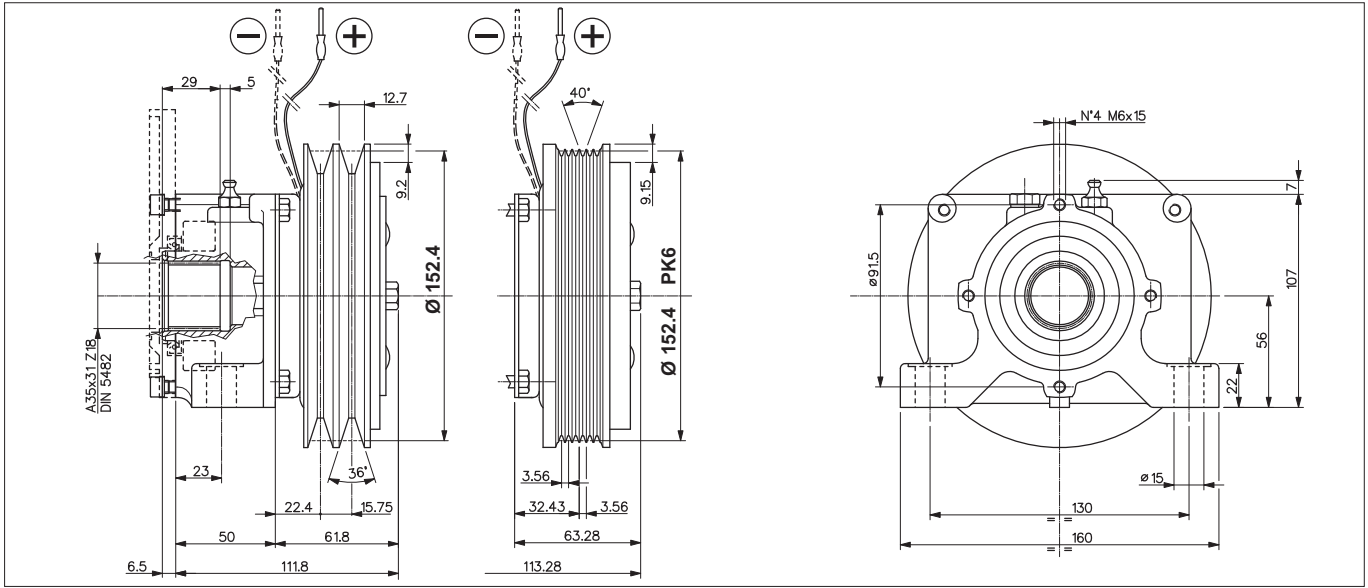

**MAXIMUM LOAD ON THE SHAFT**

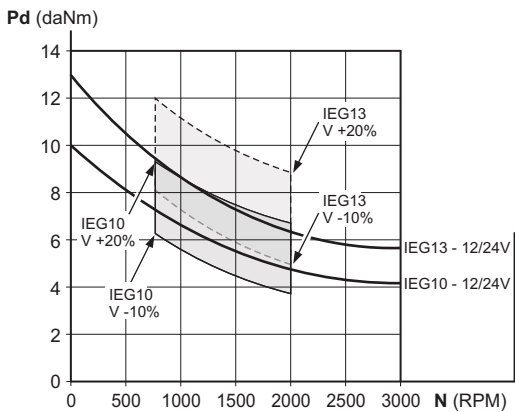

Approximate calculation of drive torque

$$P \text{ (daNm)} = c \cdot p \cdot 0,0017$$

$$P < Pd$$

where:

- p** = pump pressure in BAR
- c** = pump displacement in cc/revolution

from diagram:

- Pd** = Max. torque allowed by the coupling in daNm
- n** = Motor rotation speed in rpm.

\* Input tension and operating temperature considerably influence the correct operation of the clutch. At temperatures above 70 °C the dynamic torque rating is reduced by 20%. To reach the maximum torque, run the clutch in through repeated working cycles (ON/OFF).

An electromagnetic clutch is a unit designed to convey movement to a UT hydraulic pump through an electrically controlled on/off pulley.

- An electromagnetic clutch is composed of:
- an electromagnetic friction clutch (FE)
  - an aluminium support (SU) with a conical (AT) and splined (UT) shaft mounted on grease bearings.
  - coupling to be ordered separately

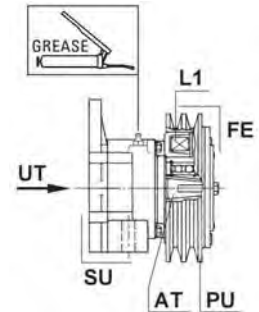

**Description**

This type of clutch exploits the force of attraction of an electromagnetic field generated by a solenoid that, after being energised (L1 in ON position), connects a pulley to a driving shaft.

- The electromagnetic friction clutch is composed of two separate parts:
- a solenoid L1, mounted on the support;
  - a pulley PU, mounted on the conical shaft AT.

Operations are as follows:

- under non operating conditions with L1 in OFF position: the pulley, driven by the "V" belt, turns idle on its own bearing,
- under operating conditions with L1 in ON position: the pulley, driven by the "V" belt, conveys movement to the shaft, then to the user UT.

**FEATURES**

RPM max	5000 RPM
Static nominal torque (*) (at 12/24V ± 0,5%)	10.2 daNm (pulley Ø152.4 - 2 races)
	10.2 daNm (pulley Ø152.4 - 6 races)
	12.2 daNm (pulley Ø177.8 - 2 races)
Power supply (*)	12 Vdc - 50W
	24 Vdc - 60W
Rotation (pulley side)	CW
Working temperature	-10 °C ÷ +45 °C
Max working temperature coil (*)	100 °C
Grease quantity	30 gr
Type of grease	DIN 51502 = MPF - 1K-20

## ORDERING CODE

3

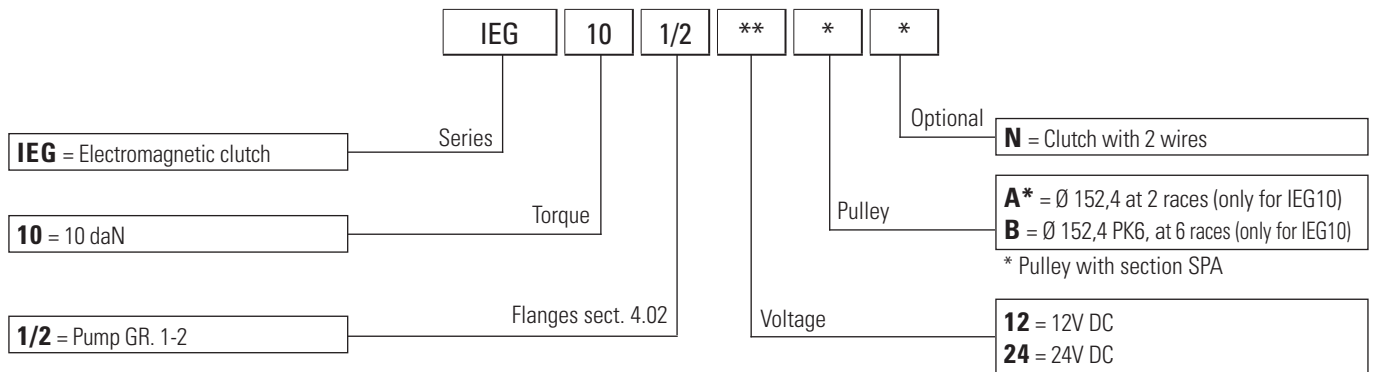

## SPARE PARTS

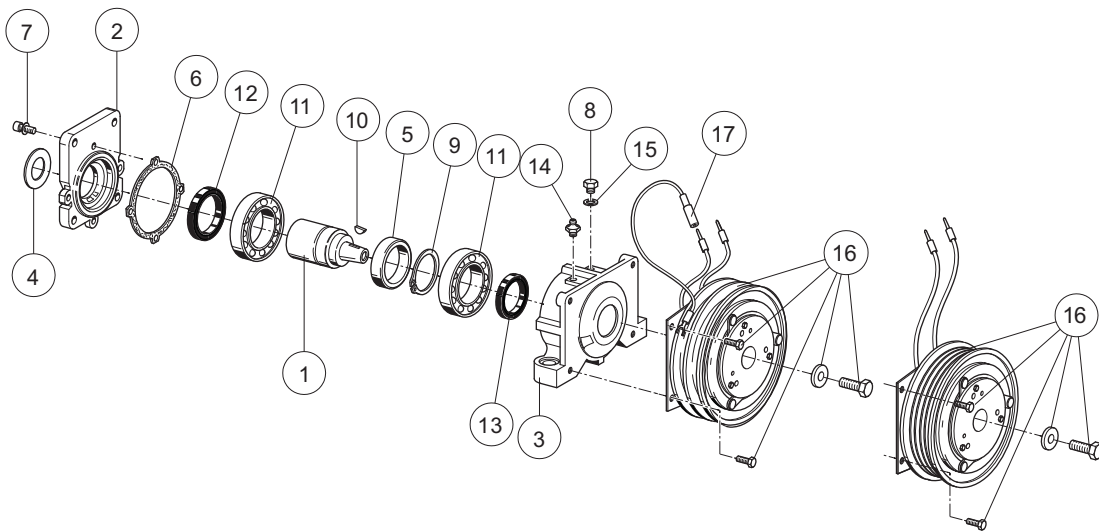

Ref.	Code	Q.ty		Description
		IEG10..A..	IEG10..B..	
1	34202300	1	1	Shaft
2	39017400	1	1	Flange Gr.1-2 (sect 4.02)
3	39021300	1	1	Body
4	39100800	1	1	Flange 44/1
5	39103000	1	1	Spacer
6	39204500	1	1	Gasket
7	40007300	4	4	Screw TCEI M6x20
8	Q26035090	1	1	Screw TEE M8x10
9	Q27150450	1	1	Snap ring E45
10	Q27500070	1	1	Key 4x5 DIN 6888
11	44000300	2	2	Bearing 6009 45x75x16

Ref.	Code	Q.ty		Description
		IEG10..A..	IEG10..B..	
12	44102200	1	1	Shaft seal 45x60x7
13	44102400	1	1	Shaft seal 35x50x7
14	49101000	1	1	Grease nipple
15	Q51437008	1	1	Washer aluminium M8 8.5x15x1.5
16	46004700	1	—	Clutch D.152.4 x 2 - 10 daNm - 12Vdc
	46004800	1	—	Clutch D.152.4 x 2 - 10 daNm - 24Vdc
	46008400	—	1	Clutch D.152.4 x 6 - 10 daNm - 12Vdc
	46008500	—	1	Clutch D.152.4 x 6 - 10 daNm - 24Vdc
17	26000005	1	—	Wire L=65

# FLANGES IM1 / IE



4

<p style="text-align: right;"><b>GR. 1*</b>    <b>1</b></p> <p style="text-align: right;">* Only for IE</p>	<p style="text-align: right;"><b>GR. 2-3</b>    <b>2/3</b></p>
<p>Spare part flange code    <b>39043000</b></p>	<p>Spare part flange code    <b>39012500</b></p>
<p style="text-align: right;"><b>SAE/A</b>    <b>S/A</b></p>	<p style="text-align: right;"><b>SAE/B</b>    <b>S/B</b></p>
<p>Spare part flange code    <b>39030600</b></p>	<p>Spare part flange code    <b>39030800</b></p>

# FLANGES IEG

<p style="text-align: right;"><b>GR. 1-2</b>    <b>1/2</b></p>	<p style="text-align: right;"><b>GR. 1-2</b>    <b>1/2</b></p>
<p>Spare part flange code    <b>39017400</b></p>	<p>Spare part flange code    <b>39022800</b></p>

# FLANGES IM05

<p style="text-align: right;"><b>GR. 1-2</b>    <b>1/2</b></p>	<p style="text-align: right;"><b>GR. 1-2</b>    <b>1/2</b></p>
<p>Spare part flange code    <b>39022800</b></p>	<p>Spare part flange code    <b>39022800</b></p>