

# PRORIL

50 Hz

## LANDVÉLAR

Designed for light weight, excellent performance, low energy consumption, and easy maintenance, PRORIL submersible handy pumps serve a wide range of pumping applications on utility, construction, industrial, and municipal job sites.

Handy and Residue Pump

## SAVVY 150

Handy Pump



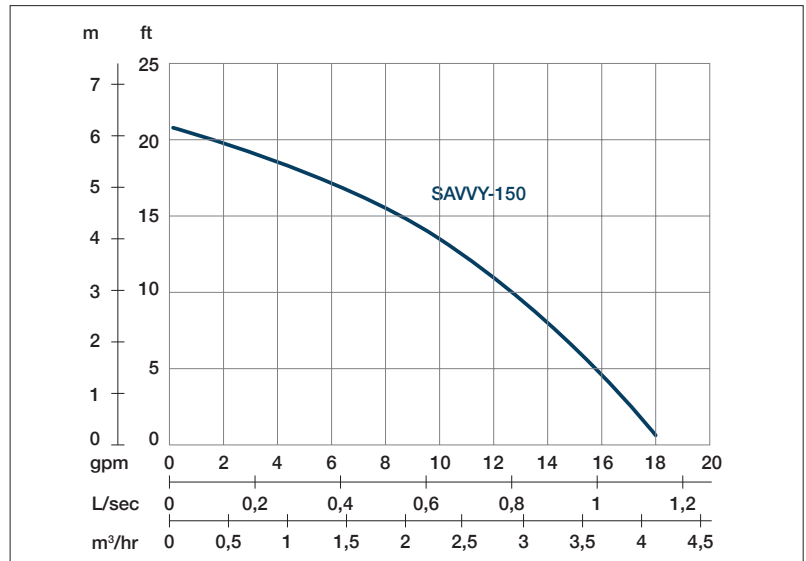

Shaft Speed : 2850 rpm    Solid Passage : 6 mm    Outlet : 25mm, 1in

OUTPUT	HEAD	FLOW
0.15 kW	Rated : 4m, 13ft	Rated : 0.7 l/s, 11gpm
0.2 HP	Max : 6.3m, 21ft	Max : 1.2 l/s, 18 gpm

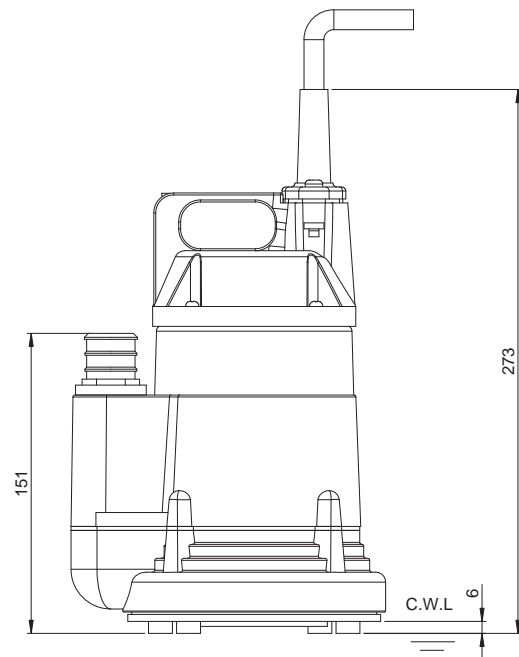
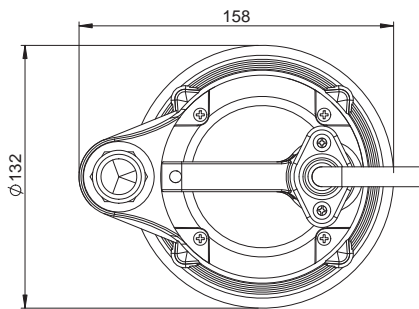

Weight : 3.2kg / 7.04lbs

Pump Type	Electric Submersible Pumps	
	1-Phase	
	IP 68	
Motor	Type	Induction Motor
	Poles	2 Pole
	Insulation	Class F
	Protector	Miniature Thermal Protector
	Starter Method	Capacitor-Run
Lubricant		Food Grade (ISO VG115)
Impeller Type		Opened
Shaft Seal		Oil Seal
Bearings		Shielded ball bearings
Cable		H07RNF
		Length: 10m (33ft) or longer upon request.
Materials	Pump Casing	Aluminum
	Impeller	Techno-polymer
	Motor Frame	Aluminum
	Motor Shaft	Carbon Steel
Max. Liquid Temperature		40°C (104°F)
Max. Submersion Depth		20m (66ft)
pH Range		pH 5 - pH 8