

PRORIL

50 Hz

LANDVÉLAR

X-SMART Series, all components in contact with liquid of the stainless steel dewatering pumps are made of 304 stainless steel. These pumps are designed for handling clean water or screened wastewater. With the use of the food-graded lubricant, they are also applicable to the aquaculture industry.

Stainless Steel Pump

X-SMART 400

Dewatering Pump



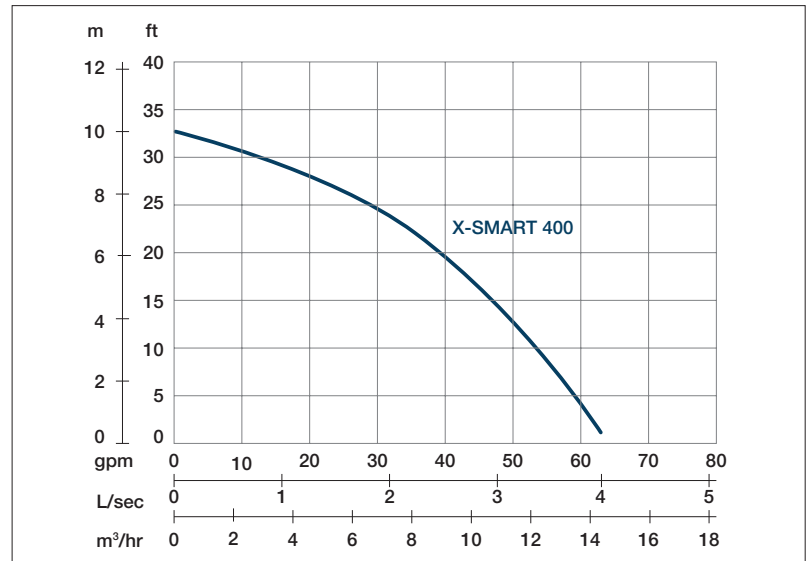

Shaft Speed : 2850 rpm Solid Passage : 5,5 mm Outlet : 50mm, 2in

OUTPUT	HEAD	FLOW
0.4 kW	Rated : 7m, 23ft	Rated : 2.3 l/s, 37 gpm
0.5 HP	Max : 10m, 33ft	Max : 4 l/s, 63 gpm

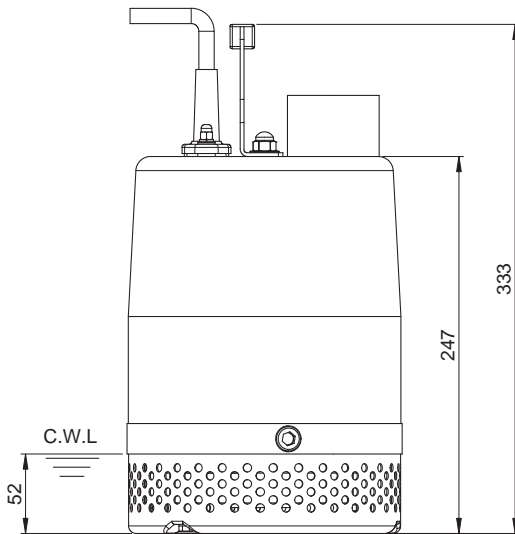
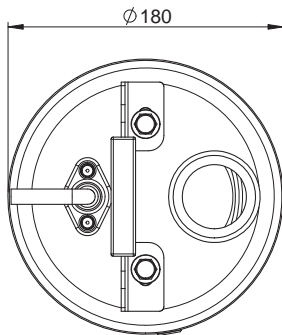

Weight : 13kg / 29lbs

Pump Type		Electric Submersible Pumps
		1-Phase
Motor	Type	Induction Motor
	Poles	2 Pole
	Insulation	Class F
	Protector	Circle Thermal Protector
	Starter	1-Phase • Capacitor-Run
Lubricant		Food Grade (ISO VG32)
Impeller Type		Opened
Shaft Seal		Double Mechanical Seal
		Silicon Carbide VS Ceramic / Carbon
Bearings		C3 Shielded ball bearings
Cable		H07RNF
		Length: 10m (33ft) or longer upon request.
Materials	Pump Casing	Stainless Steel
	Impeller	Stainless Steel
	Motor Frame	Stainless Steel
	Motor Shaft	Stainless Steel
	Strainer	Stainless Steel
Max. Liquid Temperature		104°F (40°C)
Max. Submersion Depth		66ft (20m)
pH Range		pH 5 - pH 8