

DF5 Mechanical Spool Diverter

Working conditions

This catalogue shows technical specifications and diagrams measured with mineral oil of 46 mm²/s - 46 cSt viscosity at 40°C temperature.

		DF5	DF10	DF20	DF25
N. of available ways		2-3-6	2-3-6	2-3-6	3
Nominal flow rating		60 l/min	90 l/min	140 l/min	280 l/min
Operating pressure (maximum)		315 bar 4600 psi	315 bar 4600 psi	315 bar 4600 psi	315 bar 4600 psi
Internal leakage A(B)→T	$\Delta p=100$ bar 1450 psi with fluid and valve at 40°C	5 cm ³ /min 0.31 in ³ /min	5 cm ³ /min 0.31 in ³ /min	8 cm ³ /min 0.49 in ³ /min	8 cm ³ /min 0.49 in ³ /min
Hydraulic fluid		Mineral base oil			
Fluid temperature	with NBR seals	from -20°C to 80°C			
	with FPM seals	from -20°C to 100°C			
Viscosity	operating range	from 15 to 75 mm ² /s - from 15 to 75 cSt			
	minimum	12 mm ² /s - 12 cSt			
	maximum	400 mm ² /s - 400 cSt			
Max. level of contamination		-/19/16 - ISO 4406			
	with mechanical control	from -40°C to 60°C			
Ambient temperature for working conditions	with hydraulic and pneumatic controls	from -30°C to 60°C			
	with electric controls	from -20°C to 50°C			

NOTE - For different working conditions please contact Sales Dept.

Standard threads

REFERENCE STANDARDS

		BSP	UN-UNF	NPTF	METRIC	
THREAD ACCORDING TO		ISO 228/1	ISO 263	ANSI B1.20.3	ISO 262	ISO 262
		BS 2779	ANSI B1.1 unified			
CAVITY ACCORDING TO	ISO	1179	11926		9974-1	6149
	SAE		J1926	J476a		J2244
	DIN	3852-2 shape X or Y			3852-1 shape X or Y	

PORTS THREAD

ALL PORTS	BSP	UN-UNF	METRIC (ISO 9974-1)	METRIC (ISO 6149)
DF5	G 3/8	3/4-16 (SAE 8)	M18x1.5	M18x1.5
DF10	G 1/2	7/8-14 (SAE 10)	M22x1.5	
DF20	G 3/4	1 1/16-12 (SAE 12)		
DF25	G 1	1 5/16-12 (SAE 16)		
PILOT PORTS				
Pneumatic	NPT 1/8-27	NPT 1/8-27	NPT 1/8-27	NPT 1/8-27
Hydraulic	G 1/4	9/16-18 (SAE 6)		

Optional threads: for availability contact Sales Department

2-way

Available as body only in **DF5/2** execution; for other executions 3-way body is used.

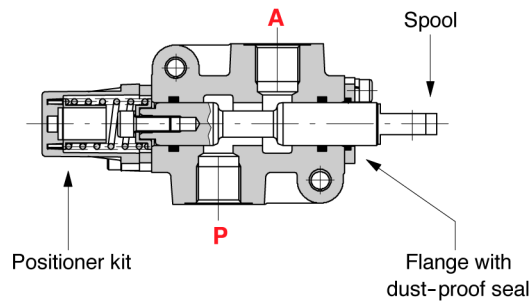

Spool type A

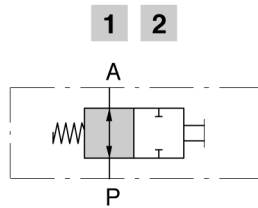

Spool type B

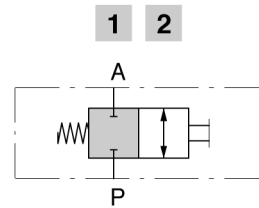

Performance data

Pressure drop versus flow
P→A

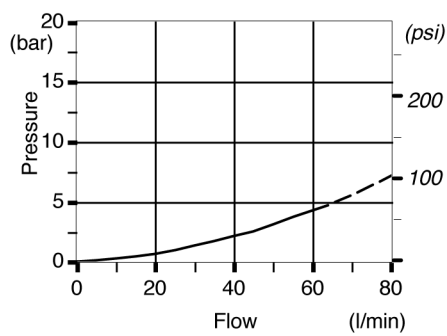

3-way

It's possible to obtain 2-way diverter valve plugging port A or B.

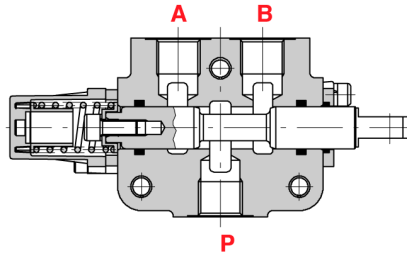

Spool type A

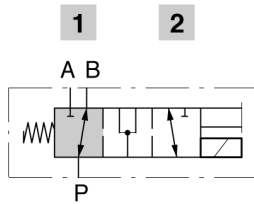

Spool type B B

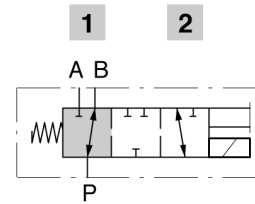

Performance data

Pressure drop versus flow: P→A(B)

DF5/3

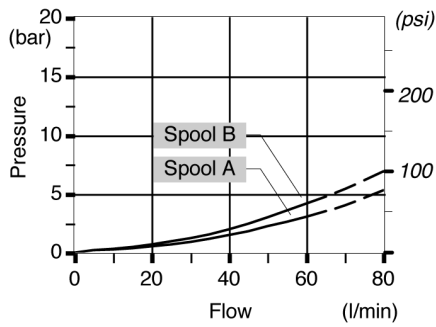

DF10/3

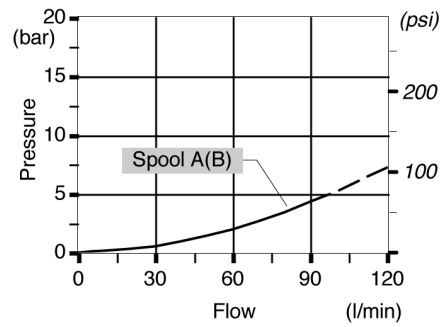

DF20/3

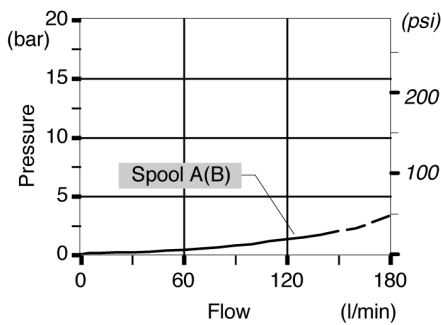

DF25/3

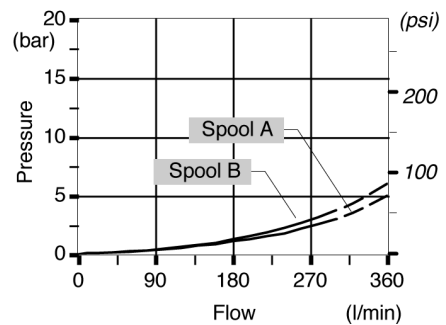

6-way

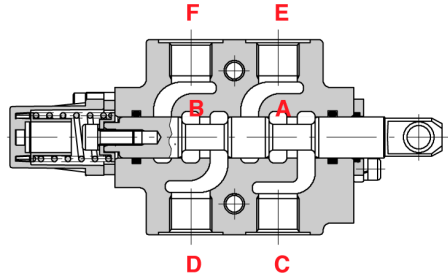

Spool type A

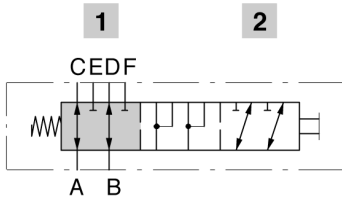

Spool type B

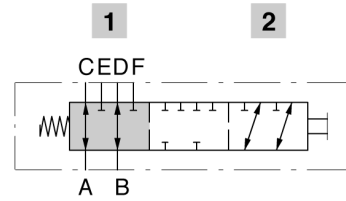

Performance data

Pressure drop versus flow: A→C(E).

DF5/6

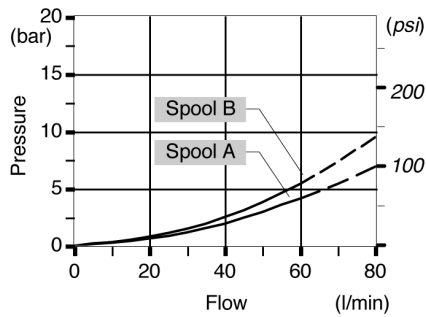

DF10/6

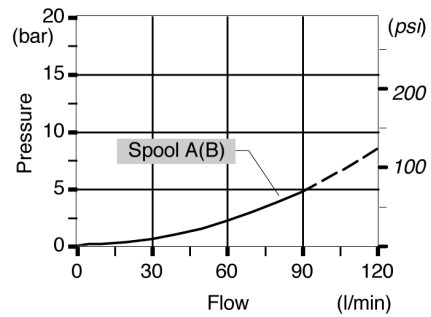

DF20/6

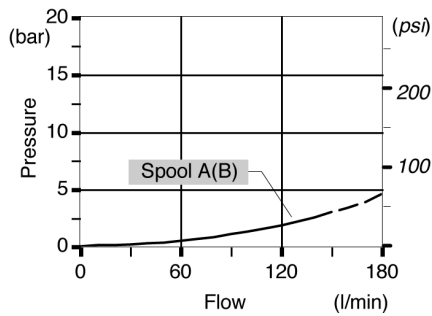

2-way DF5/2 valve

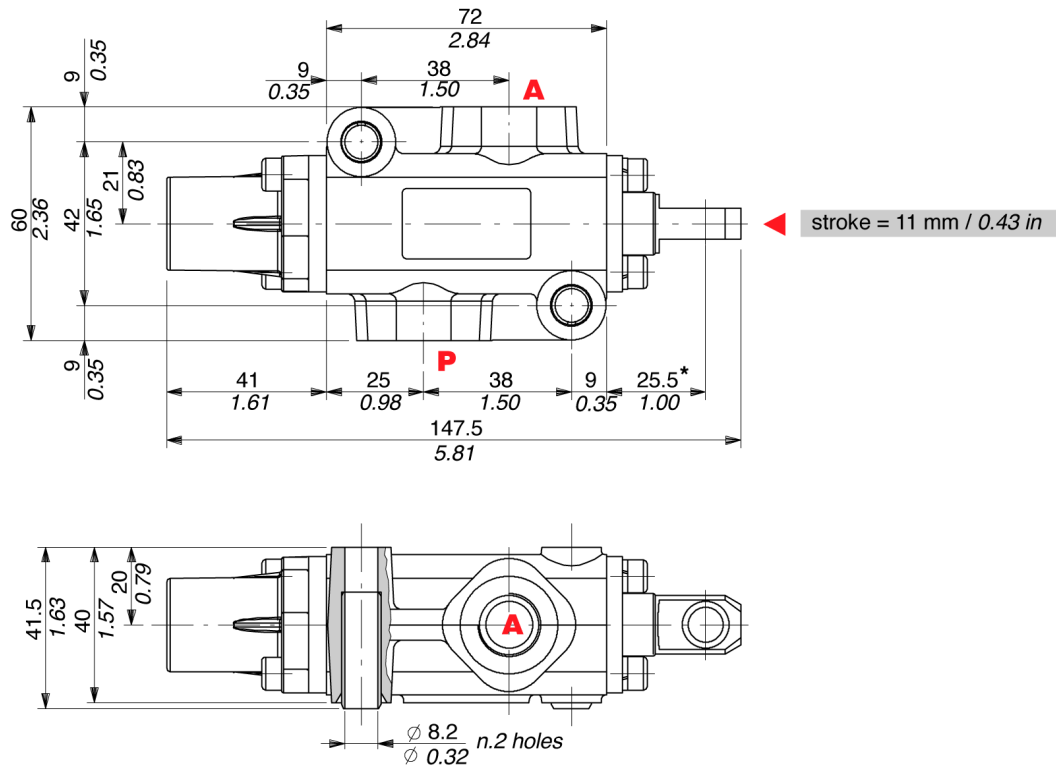

3-way DF5/3 valve

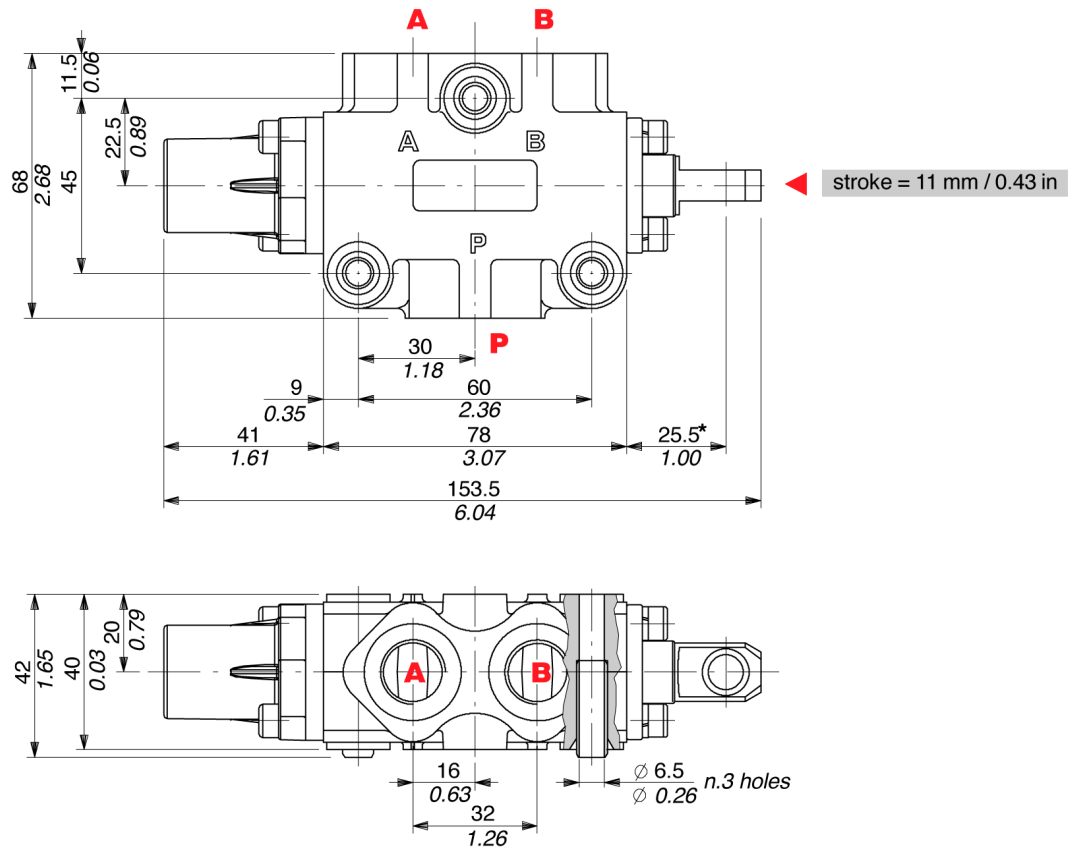

6-way DF5/6 valve

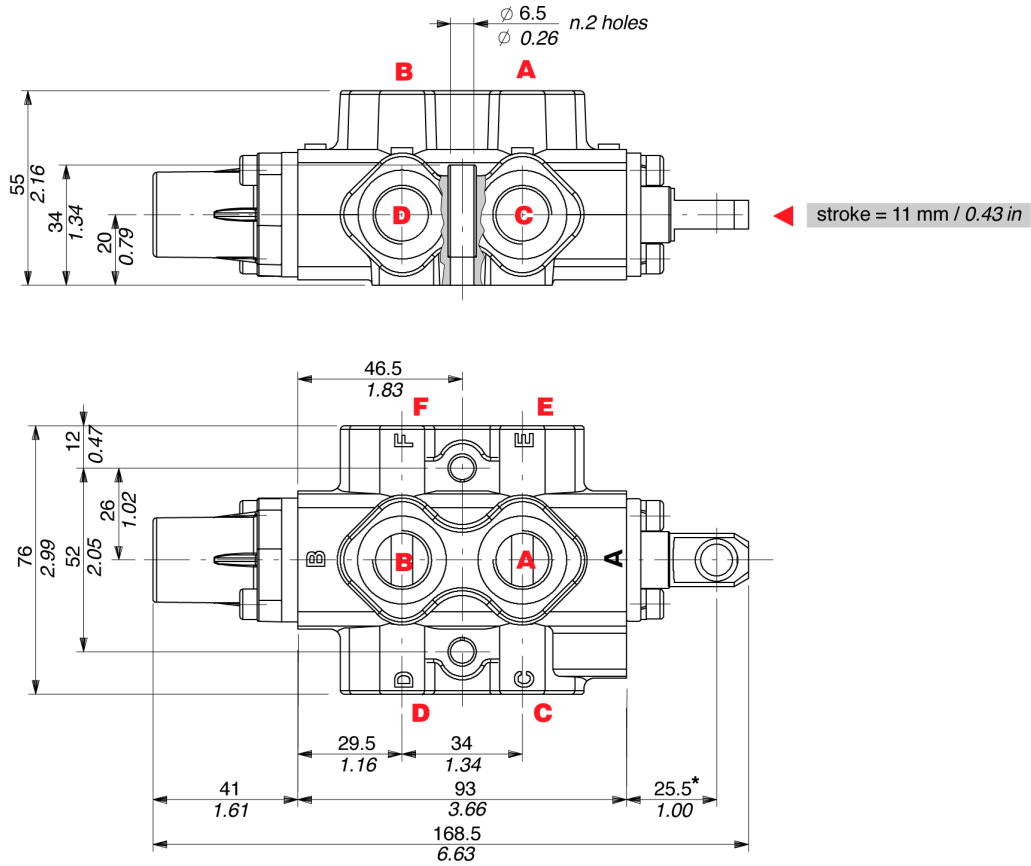

Spool end

Standard end

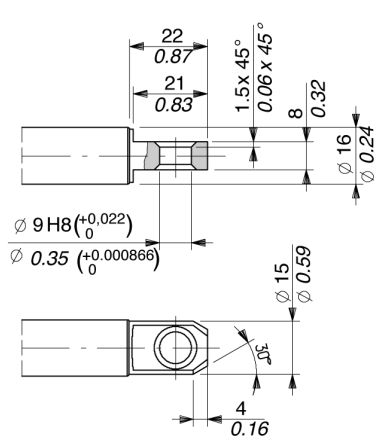

NOTE (*) - With spool out
(positioner kit type 17)

Spherical end type T

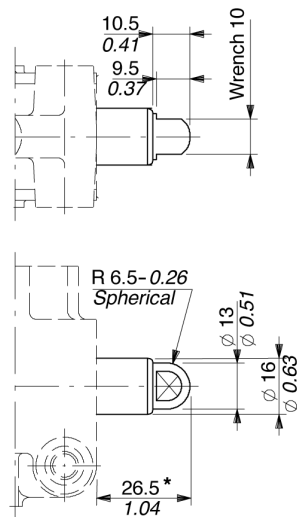

Rotary cam prearrangement

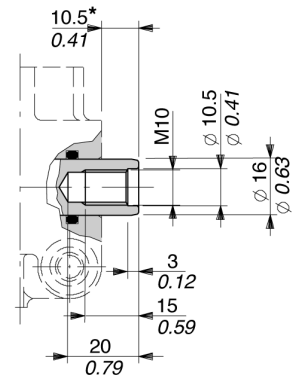

Description example:

Diverter valve DF5/3 A 17 SLP

- 1.
- 2.
- 3.
- 4.

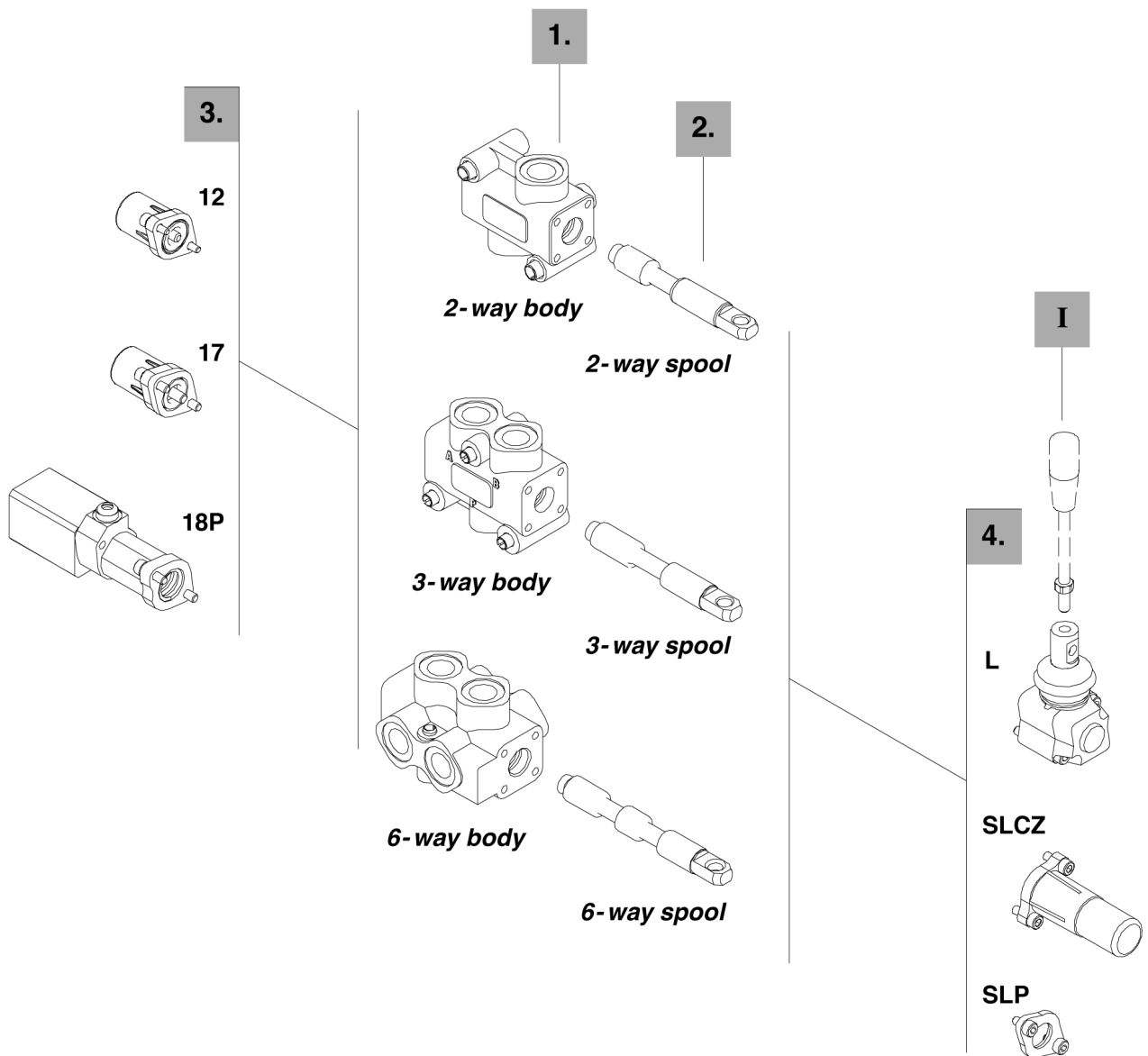

2-way

1. Kit corpo *

TYPE	BODY	DESCRIPTION
DF5/2	5CO2220300	Standard body kit

Include body and seals

2. Spool options

TYPE	CODE	DESCRIPTION
A	3CAS105210	2 positions with open centre in neutral
B	3CAS105110	2 positions with closed centre in neutral
AT	3CAS105230	As type A with spherical end
BT	3CAS105130	As type B with spherical end
AC	3CAS105220	As type A prearranged for cam control
BC	3CAS105120	As type B prearranged for cam control

3-way

1. Body kit *

TYPE	CODE	DESCRIPTION
DF5/3	5CO2221300	Standard body kit

Include body and seal

2. Spool options

TYPE	CODE	DESCRIPTION
A	3CAS105310	3-way, 2 positions with ports connected in transit position
B	3CAS105410	3-way, 2 positions with ports closed in transit position
AT	3CAS105330	As type A with spherical end
AC	3CAS105320	As type A prearranged for cam control
BC	3CAS105420	As type B prearranged for cam control

6-way

1. Body kit *

TYPE	CODE	DESCRIPTION
DF5/6	5CO2222300	Standard body kit

Include body and seals

2. Spool options

TYPE	CODE	DESCRIPTION
A	3CAS105610	6-way, 2 positions with ports connected in transit position
B	3CAS105710	6-way, 2 positions with ports closed in transit position
AC	3CAS105620	As type A prearranged for cam control
BC	3CAS105720	As type B prearranged for cam control

3. Positioner kits

TYPE	CODE	DESCRIPTION
12	5V12105000	Detent in positions 1 and 2
17	5V17105000	Spring return in position 1
17Y	5V17105010	As type 17, it must be coupled to IA2 control
18ME	5V18405110	Spring return in position 2
18P	5V18105700	ON/OFF pneumatic kit with spring return in position 2
18IA1	5V18105820*	ON/OFF high pressure hydraulic kit with spring return in position 2
18IB1N	5V18105811*	Comando idraulico a bassa pressione con ritorno a molla in posizione 2

4. Control kits

TYPE	CODE	DESCRIPTION
SLP	5COP105000	Without lever box with dust-proof plate kit
SLCZ	5COP205030	Without lever box with endcap
TQ	5TEL105110	Flexible cable connection
L	5LEV105000	Standard kever box
CB	5CAM105020	Cam control
IA2	5IDR505000*	ON/OFF high pressure hydraulic control
IB2	5IDR705000*	ON/OFF low pressure hydraulic control

I Optional handlever

TYPE	CODE	DESCRIPTION
AL01/M8x120	170011012	For lever L: height 120 mm / 4.72 in

NOTE (*) - Codes are referred to **BSP** thread.