

Specifications

Frame size VP1--	045	075	095	110	130
Displacement [cm ³ /rev]	45	75	95	110	128
Max operating pressure [bar]					
continuous	350	350	400	400	400
intermittent ¹⁾	400	400	420	420	420
Mass moment of inertia J [kgm ²]	0.00606	0.00606	0.00681	0.00690	0.00690
Selfpriming speed ²⁾ [rpm]					
2" suction line, max	2200	1700	1250	1100	900
2 1/2" suction line, max	2400	2100	1750	1500	1300
3" suction line, max	-	-	2200	2100	1900
Max Speed unloaded [rpm]					
(in bypass mode, no flow)	3000	3000	3000	3000	3000
Control type	LS				
Shaft end spline	DIN 5462				
Mounting flange	ISO 7653-1985				
Weight (with control) [kg]	27				

1) Max 6 seconds in any one minute.

2) At an inlet pressure of 1.0 bar (abs.) with mineral oil at a viscosity of 30 mm²/s (cSt).

VP1-045/-075 cross section

1. Inlet port
2. 'Top' purge plug
3. Return spring
4. Control
5. Setting piston (one of two)
6. Swash plate
7. Bearing shell
8. End cover
9. Spline (for mounting an auxiliary pump)
10. Plain bearing
11. Hold-down plunger
12. Valve plate
13. Cylinder barrel
14. Barrel housing
15. 'Bottom' purge plug
16. Piston with piston shoe
17. Retainer plate
18. Bearing housing
19. Roller bearing
20. Shaft seals with carrier
21. Input shaft

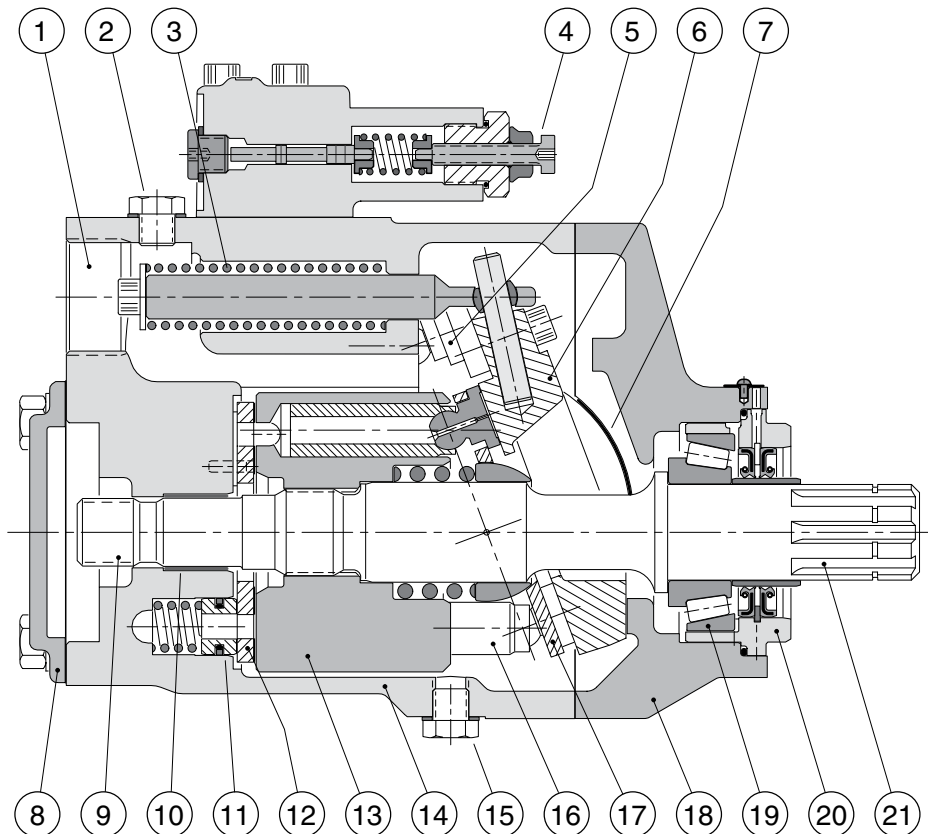

VP1-045 and -075

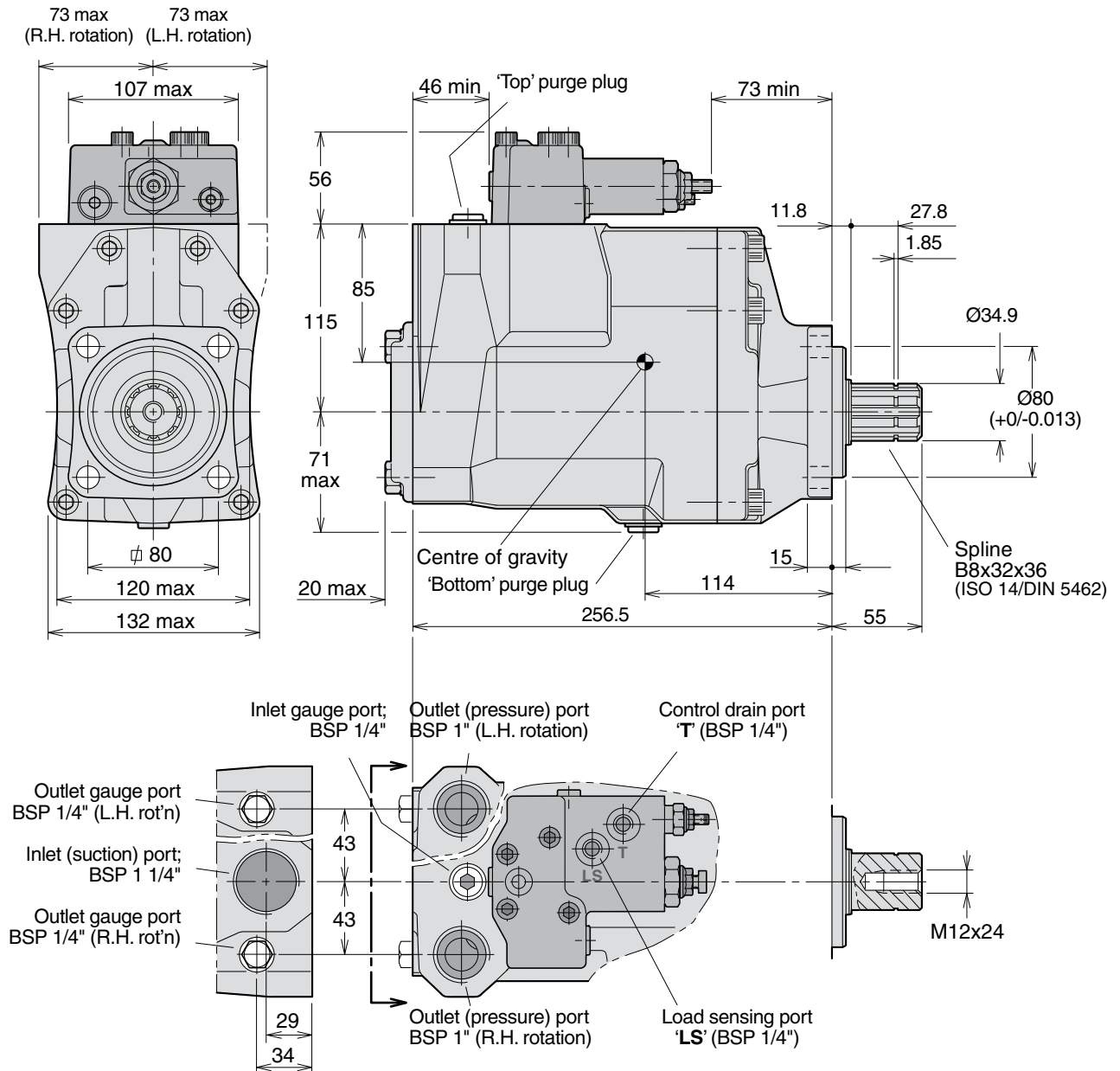

9

IMPORTANT
 The control is *not* drained through the pump case. An external line *must be installed* between the control drain port 'T' and the reservoir.

NOTE: The pump **does not** include a suction fitting; it must be ordered separately. See chapter 11.

LS valve block VP1-045/075

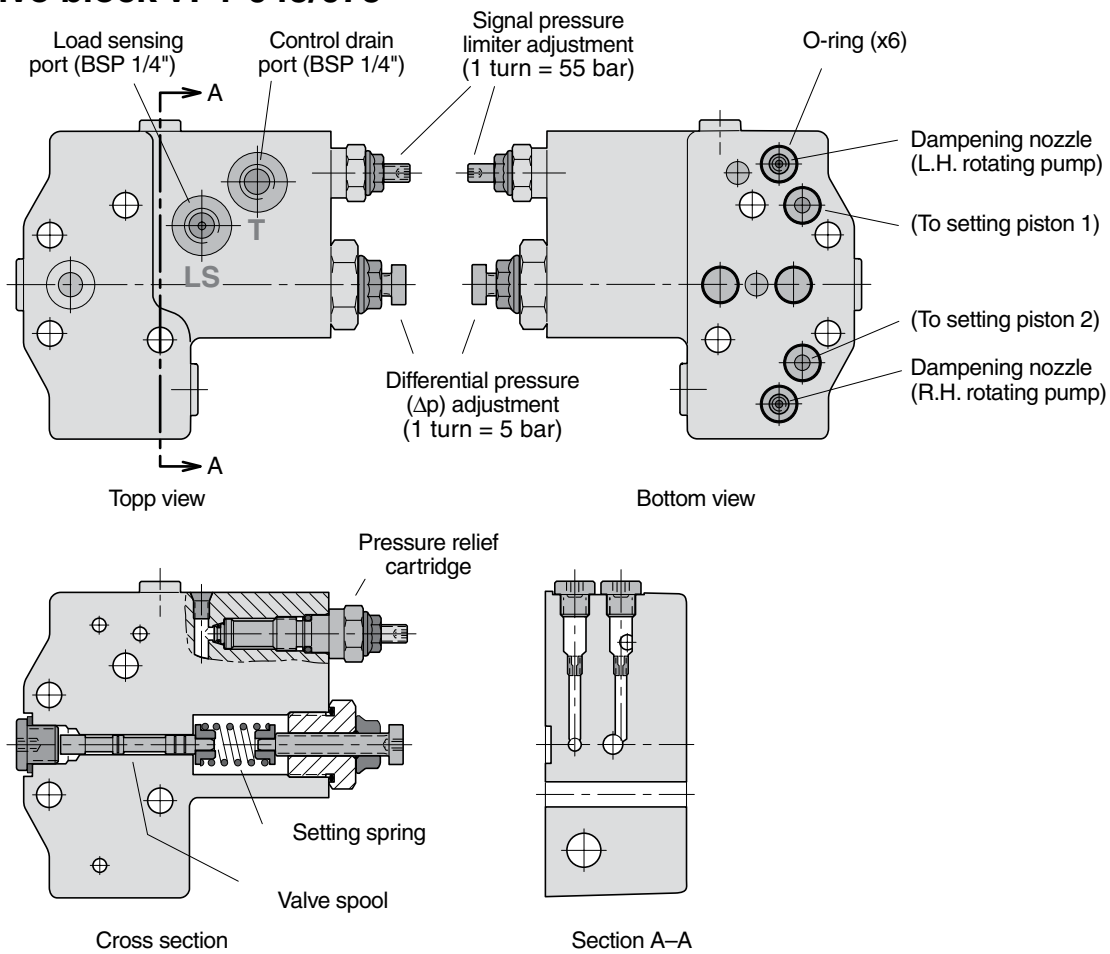

Fig. 2. LS valve block.

Through-shaft coupling VP1-045/075

The VP1 pump has a through-shaft which means that an additional pump, such as a fixed displacement F1, can be installed in tandem with the VP1 by means of an adaptor kit (fig. 3).

NOTE: The bending moment caused by the weight of a tandem assembly normally exceeds that allowed by the PTO.

To prevent damage, the auxiliary pump should be supported by a bracket attached to the gearbox; it *must not* be fastened to the truck chassis.

Likewise, when the tandem assembly is installed on a separate bracket and driven by a cardan shaft, the auxiliary pump should have a support attached to the pump bracket.

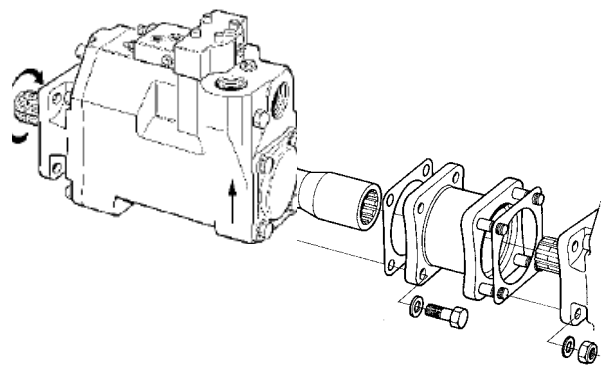

Fig. 3. Adaptor kit (P/N 379 7795) for tandem coupling.

IMPORTANT

Contact Parker Hannifin for additional information when considering tandem mounting a second VP1 pump.
 The maximum torque that can be transmitted through the first pump VP1-045/75 in tandem is 420 Nm.

VP1-095/-110/-130 cross section

1. Shaft seal
2. Roller bearing
3. 'Upper' purge plug
4. Bearing shell
5. Setting screw (pressure relief valve)
6. Setting bushing (standby pressure)
7. Control
8. Piston with piston shoe
9. 'Upper' setting piston (control pressure)
10. Needle bearing
11. Shaft
12. Drain hole, shaft seals
13. 'Lower' purge plug
14. Bearing housing
15. Swash plate
16. Retainer plate
17. 'Lower' setting piston (pump pressure)
18. Cylinder barrel
19. Valve plate
20. Barrel housing

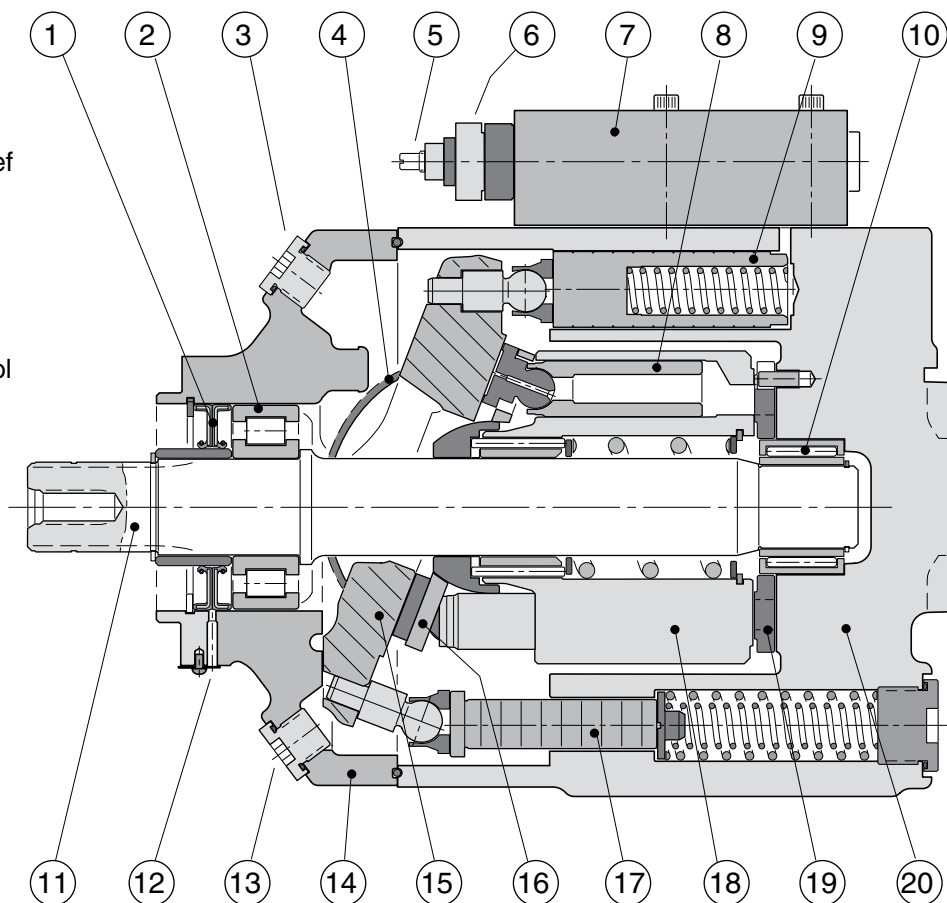

LS control (for VP1-095/-110/-130)

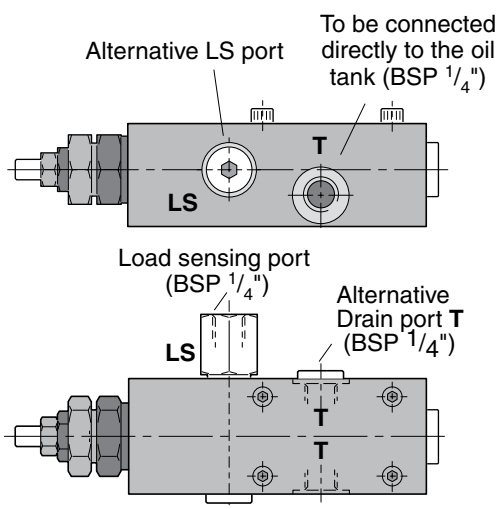

LS control ports.

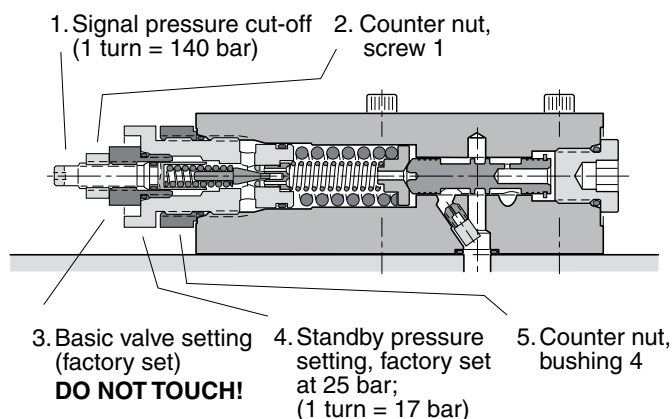

LS control cross section.

Item	Wrench / dimension
1	Hex Head Wrench / 4 mm
2	Wrench / 13 mm
3	DO NOT TOUCH
4	Wrench / 27 mm
5	Wrench / 27 mm

NOTE: Always run a function, after adjusting the standby pressure or the max pressure setting, before you read the value.

VP1-095/-110/-130

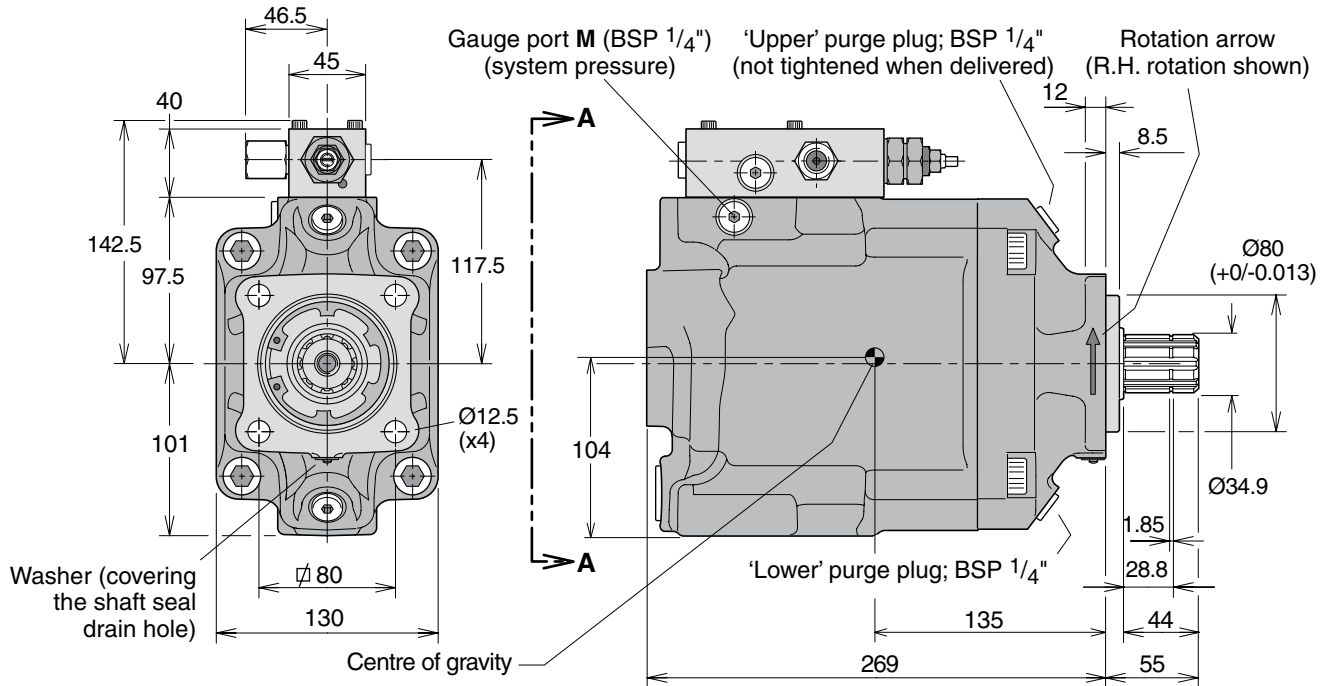

NOTE: The pump **does not** include a suction fitting; it must be ordered separately. See chapter 11.

IMPORTANT!
 The control is **not** drained through the pump case; an external drain line must be installed from control port T and, directly, to the oil tank.

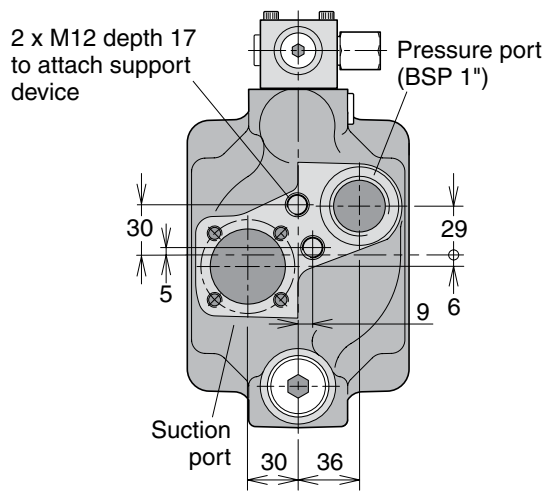
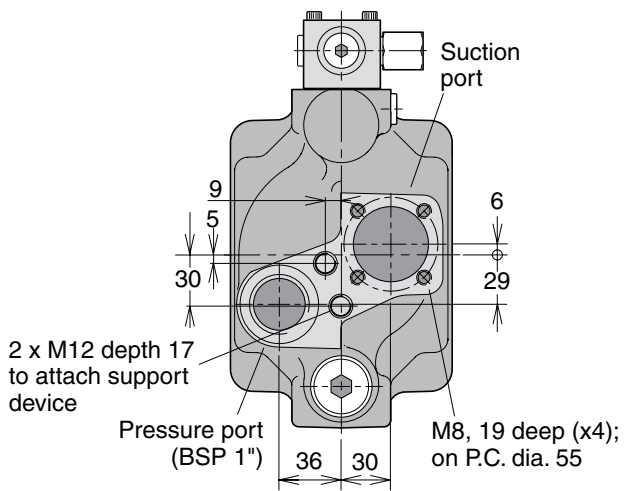
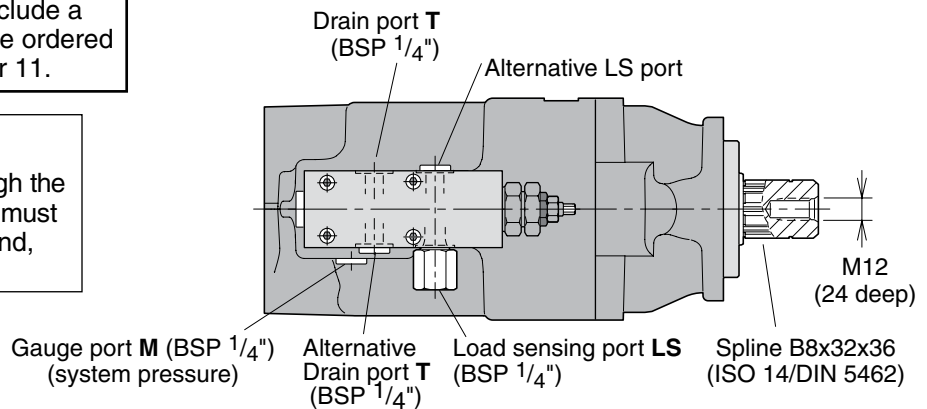

Ordering information

Example: **VP1 - 045 - L**

Frame size

045, 075, 095, 110 or 130

Direction of rotation

L Left hand
R Right hand

NOTE:

The VP1 is uni-directional.
 Consequently, the desired direction of rotation must be stated *when ordering*.

Standard model numbers

Designation	Ordering no. No Paint	Ordering no. Black Paint
VP1-045-R	378 0334	378 6169
VP1-045-L	378 0335	378 6170
VP1-075-R	378 0336	378 6171
VP1-075-L	378 0337	378 6172
VP1-095-R	378 6000	378 6003
VP1-095-L	378 6001	378 6002
VP1-110-R	378 4110	378 3814
VP1-110-L	378 4111	378 3815
VP1-130-R	378 4500	378 4507
VP1-130-L	378 4501	378 4508

VP1 in load sensing systems

When installed in a load sensing system, the VP1 supplies the correct amount of flow required by the various work functions currently engaged.

This means that energy consumption and heat generation are minimised and much reduced in comparison with a fixed displacement pump used in the same system.

Diagram 1 shows the required power (flow times pressure) in a constant flow system with a fixed displacement pump.

Diagram 2 shows the sharply reduced power requirement in a load sensing system with a variable displacement pump such as the VP1.

In both cases the pump pressure is slightly higher than what is required by the heaviest load ('Load 2') but the VP1, because of the much smaller flow being delivered, needs only the power indicated by the shaded area 'Load power'.

In a constant flow system, on the other hand, excess fluid is shunted to tank and the corresponding power, 'Wasted power' (shown in diagram 1), is a heat loss.

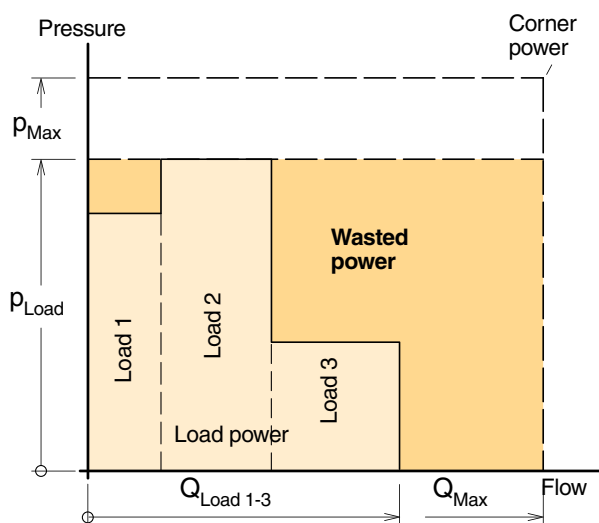

Diagram 1. Constant flow system with a fixed displacement pump.

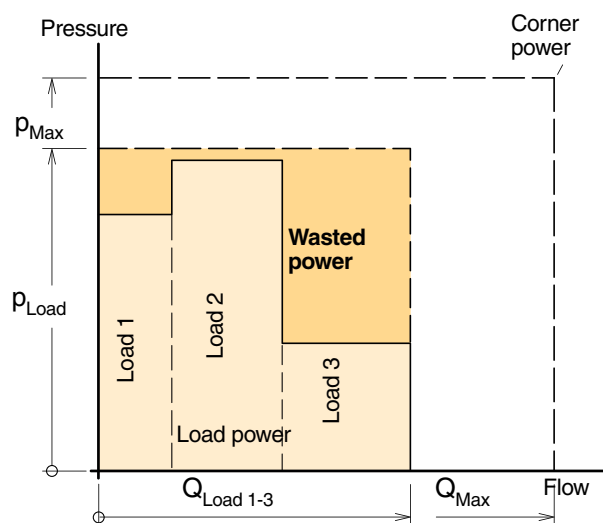

Diagram 2. Constant flow system with a variable displacement pump (e.g. VP1).

Systems comparison

System	Constant flow	Load-sensing
Pump	Fixed displ.	VP1 variable displ.
Pump adjustments	Pressure only	Pressure and flow
Load *	Some influence	Some influence
Energy consumption	High	Low
Heat generation	High	Low

* Simultaneous operation of loads with non-equal flows and pressures; refer to the above diagrams.