



SVH 062, 092, 112, 130



The Sunfab variable displacement pump with its rugged construction is designed for direct mounting at the auxiliary drive (P.T.O.) of commercial vehicles.

With a max. displacement of 130 cm³/rev. and a peak pressure of 450 bar it is suited for many applications. This is complemented by the high self priming rate and the low noise level. The pump delivery flow is dependent on the present drive speed and geometric displacement. The flow is adjustable in a range between 0 and Q_{max}.

Long service life is ensured due to the pressurized lubrication of the swash plate bearing shell.

Sunfab SVH is rotation-direction dependent and should be ordered in either right-hand or left-hand designs.

Other advantages of Sunfab SVH:

- Short reaction time when resetting the flow
- Compact installation dimensions
- High working pressure level allowed
- Externally drained for best cooling
- Rugged construction and long service life
- Low noise emission
- High power-to-weight-ratio



Versions, main data

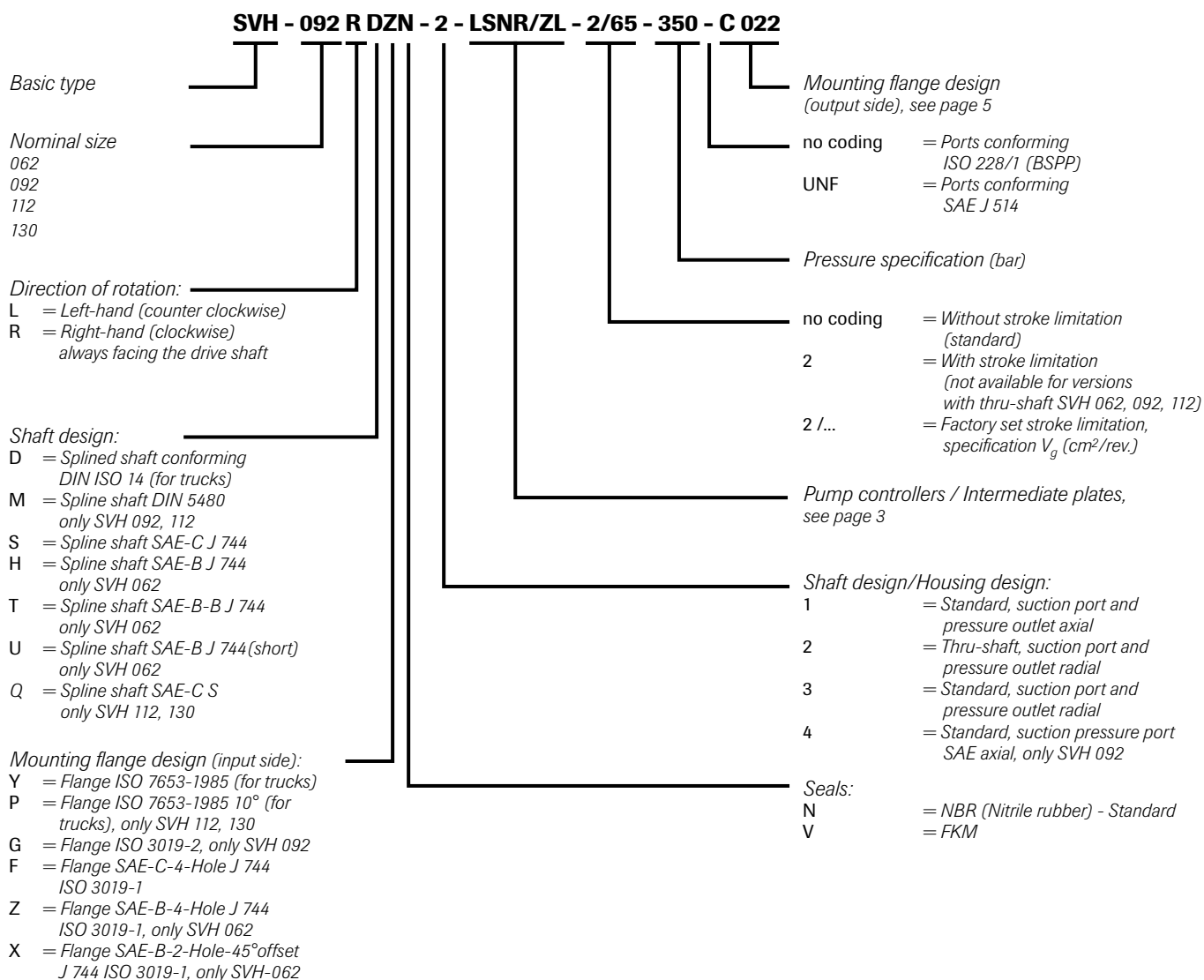

Type		SVH 062	SVH 092	SVH 112	SVH 130
Geometric displacement V_g	cm ³ /rev.	62.4	87.2	110.4	130
Nom. pressure p_{nom}	bar	350	350	350	400
Pressure p_{max}	bar	400	400	400	450
Angle of the swash plate		21.5°	21.5°	21.5°	21.5°
Required inlet pressure (absolute) for open circuit	bar	0.85	0.85	0.85	0.85
Max. permissible inlet pressure, absolute	bar	2	2	2	2
Max. permissible housing pressure, absolute	bar	3	3	3	3
Max. permissible drive torque (flange/shaft)	Nm	430	530	900	900
Max. torque for the pump (with power controller)	Nm	430	530	600	700
Max. permissible torque for the thru-shaft, dep. on flange	Nm	100	530	600	700
Max. rev. rating when self priming and max. angle of the swash plate at 1 bar absolute inlet pressure	rpm	2500	2300	2200	2100
Min. rev. rating for permanent running	rpm	500	500	500	500
Required torque at 100 bar	Nm	100	151	184	230
Drive power for 250 bar and 2000 rpm	kW	53	79,5	97.2	120
Mass (weight) complete with controller	kg	24	27	30	30.8
Tare weight torque	Nm	30	35.3	40	40
Inertia moment	kg m ²	0.005	0.008	0.01	0.011
Sound level at 250 bar, 1500 rpm and max. swash plate angle (Measured in a sound measuring room DIN ISO 4412, distance 1 m)	dB(A)	75	75	75	75



Description of the controllers

LSNR	Load-Sensing controller with integrated pressure limitation
NR	Pressure controller, adjustable directly at the pump. The Pressure controller automatically maintains a constant system pressure independent of the required flow. Therefore it is suited for constant pressure systems, where differing flow is required or as efficient pressure limitation of the hydraulic system
Intermediate plates	Intermediate plate only in combination with controllers LSNR or NR
/ZL	SVH 062, 092, 112: Intermediate plate with power controller (torque limitation) Product "Pressure x Displacement" = constant Adjustment range: 25...100% of max. drive torque
/ZW	Angled intermediate plate (45°) mandatory for mounting controllers at pumps with housing design -2, -3
/L	SVH 130: Power controller (torque limitation), default option Adjustment range: 200-700 Nm Factory setting: 700 Nm

Controller

Coding /LSNR, NR

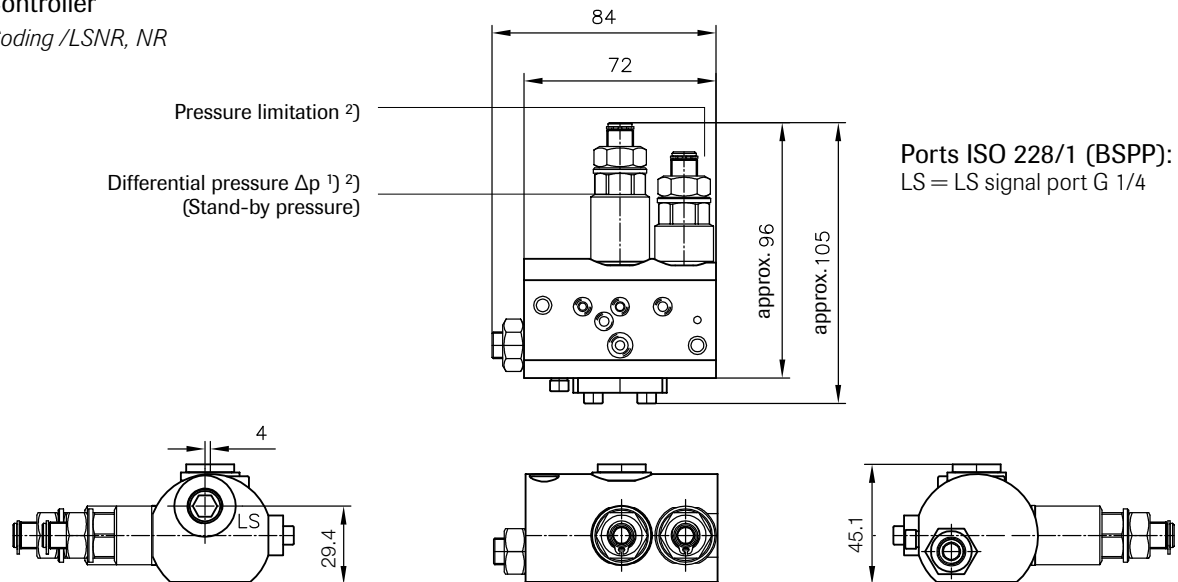

Intermediate plate

Coding /ZW version with thru-shaft

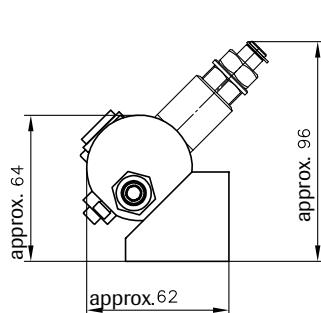

Controller

Coding /ZL intermediate plate version

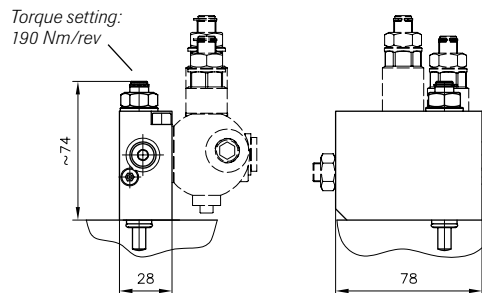

Controller

Coding /L

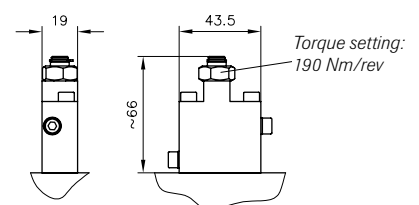

Pressure adjustment	Pressure range (bar)	Δp (bar)/rev.	Pressure setting, factory set (bar)
Pressure limitation	20 ... 400	50	350
Differential pressure Δp	20 ... 55	10	27

¹⁾ Applies only coding LSNR. ²⁾ The adjustment range is limited by a mechanical stop. **Attention:** Always use a pressure gauge when changing the pressure setting!

Controller symbols

Coding **LSNR**

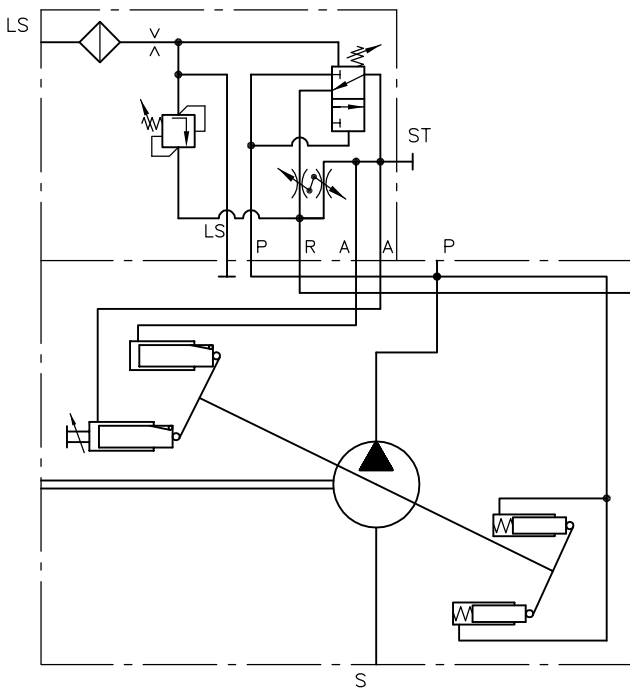

Coding **NR**

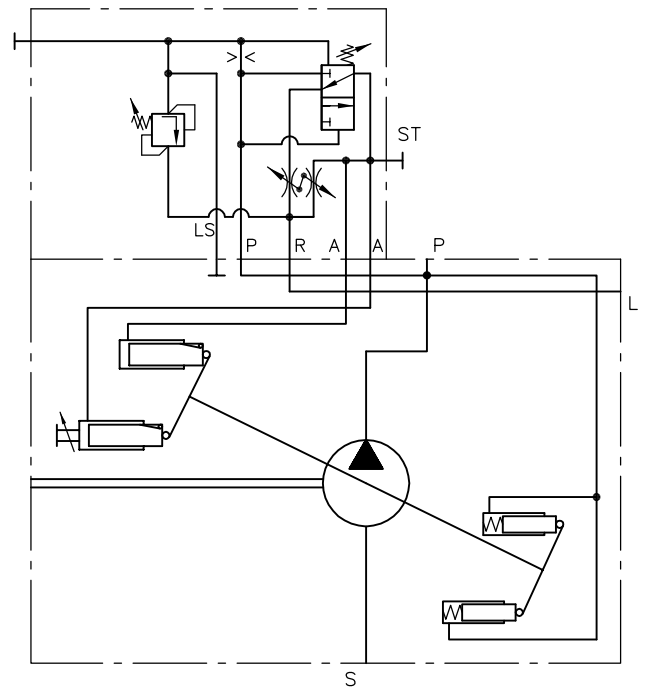

Coding **.../ZL**

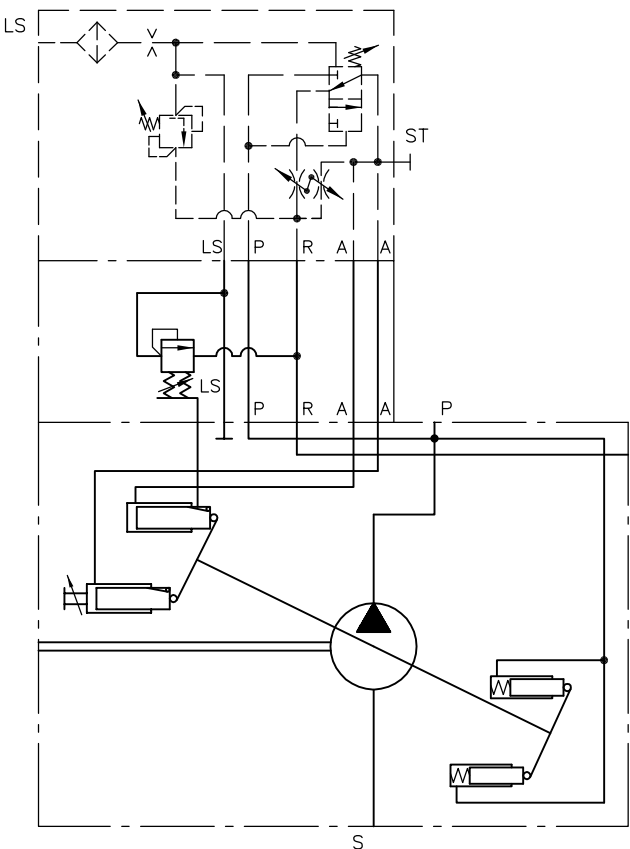

Coding **.../L**
for SVH 130

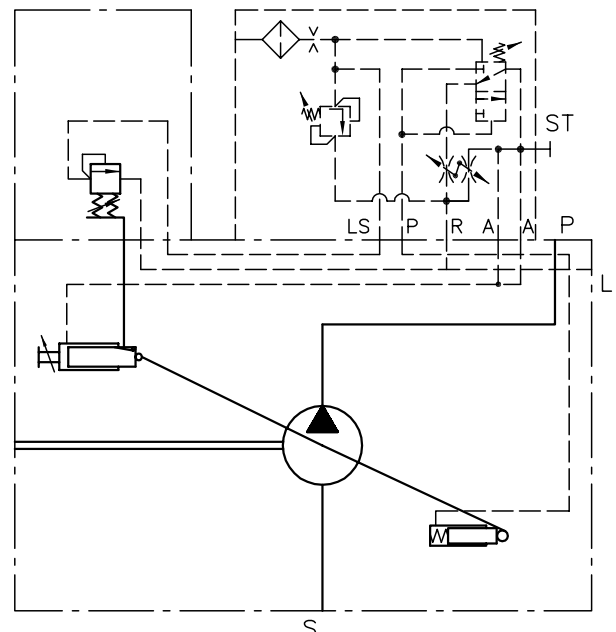



Additional parameter, general

Calculation of the nom. sizes:

Flow rate

$$Q = \frac{V_g \times n \times \eta_v}{1000} \text{ (lpm)}$$

Torque

$$M = \frac{1,59 \times V_g \times \Delta p}{100 \times \eta_{mh}} \text{ (Nm)}$$

Power

$$P = \frac{2\pi \times M \times n}{60000} = \frac{M \times n}{9549} = \frac{Q \times \Delta p}{600 \times \eta_t}$$

V_g Displacement (cm³/rev.)

η_v = Volumetric efficiency

Δp Differential pressure (bar)

η_{mh} = Mechanical-hydraulic efficiency

n Speed (rpm)

η_t = Total efficiency ($\eta_t = \eta_v \times \eta_{mh}$)

Nomenclature

Axial piston pump according to the swash plate principle

Mounting

At the auxiliary drive of commercial vehicles

(flange ISO 7653-1985 for trucks) or flange assembly

(flange ISO 3019-2 or SAE/ISO 3019-1)

Surface

Gas nitrocarburized SVH 062, 092, 112. Painted SVH 130

Direction of rotation

Right or left

Changing the rotation direction

Contact Sunfab

Installed position

Any (observe the installation instructions)

Hydraulic fluid

Hydraulic oil acc. to DIN 51524 part 1 to 3; ISO VG 10 to 68 acc. to DIN 51519

Viscosity range: min. approx. 10; max. approx. 1000 mm²/sec

Optimal operation range: approx. 20...50 mm²/sec. Also suitable are biologically degradable pressure fluids type HEES (synth. Ester) at operation temperatures up to approx. +70 °C.

Temperature

Ambient: approx. -40...+60 °C

Fluid: -25...+80 °C, pay attention to the viscosity range!

Start temperature down to -40 °C is allowable (Pay attention to the viscosity range during start!),

as long as the operation temperature during subsequent running is at least 20 °C higher.

Filtration

Should conform to ISO standard 4406 code 21/18/15 ...19/17/13

Mounting flange design (output side)

Available, incl. coupling sleeves

Coupling flange for universal joint shafts

Coding, SVH			Flange	Shaft
062	092-112	130		
C 011	C 021	C 031	SAE A-2-Hole	9T 16/32 DP
C 012	C 022	C 032	SAE A-2-Hole	9T 16/32 DP ¹⁾
C 013	--	--	SAE A-2-Hole	11T 16/32 DP
C 014	C 024	C 034	SAE B-2-Hole	13T 16/32 DP
C 015	C 025	C 035	SAE B-4-Hole	13T 16/32 DP
--	--	--	SAE B-B-2-Hole	15T 12/24 DP
--	C 027	--	SAE C-2-Hole	14T 12/24 DP
--	C 028	C 038	SAE C-4-Hole	14T 12/24 DP
--	--	--	SAE C-C-2-Hole	17T 12/24 DP

Attention: Observe the max. drive torque rating!

Note: An additional support has to be provided in case of pump combinations.

Additional versions on request!

¹⁾ ANSI B 92.1, FLAT ROOT SIDE FIT

The spline width is not conforming the industrial standard. $s = 2.357_{-0,03}$

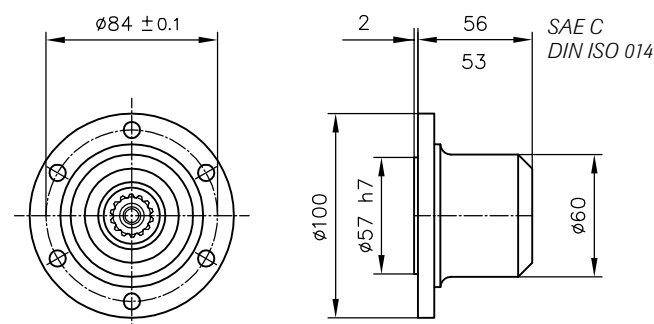

Coding	Spline profile
SAE C	14T 12/24 DP
DIN ISO 014	B8x32x36



Curves

Flow and Power

Charts show flow/pressure (without controller). Power at max. setting angle and power at min. setting angle and 1500 rpm

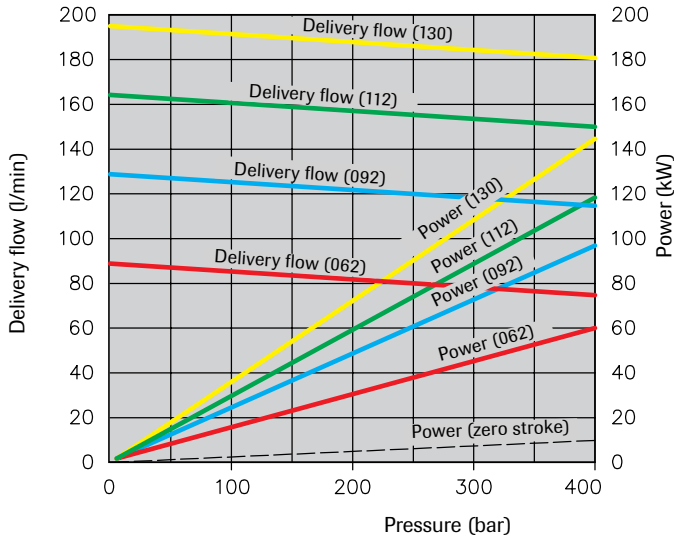

Inlet pressure (LSNR-controller)

Graph valid at viscosity 75 mm²/s at max. setting angle.

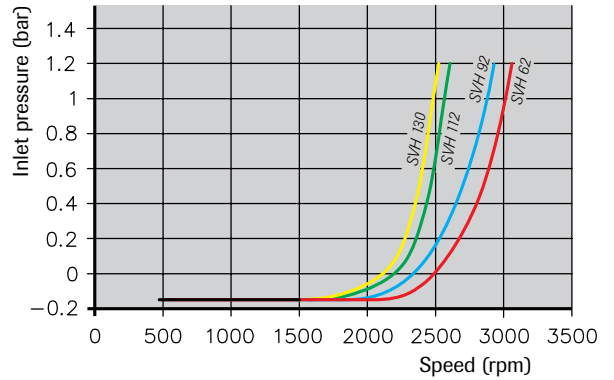

Controller curve

Coding L

Pressure / Delivery flow

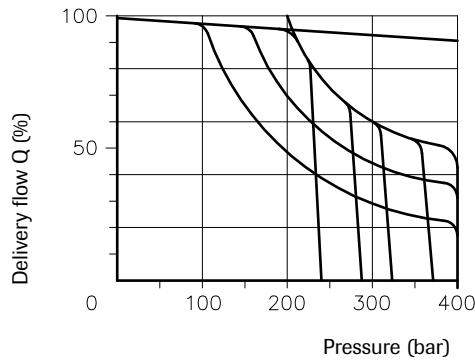

Response time T₁ (LSNR-controller)

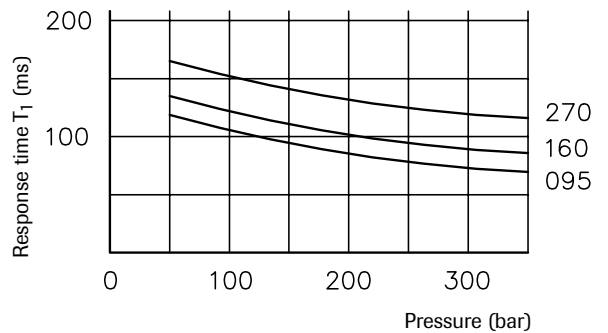

Coding LSNR

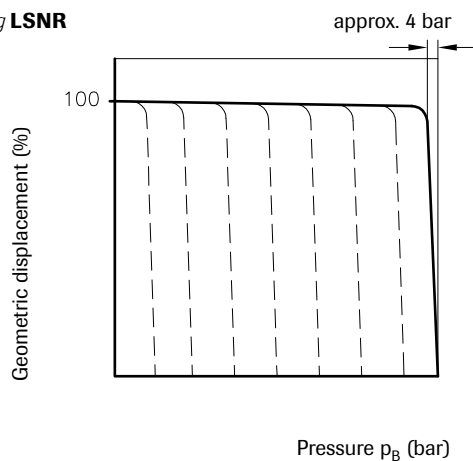

Response time T₂ (LSNR-controller)

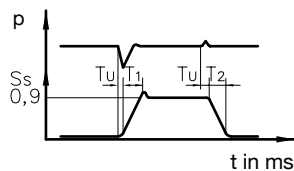
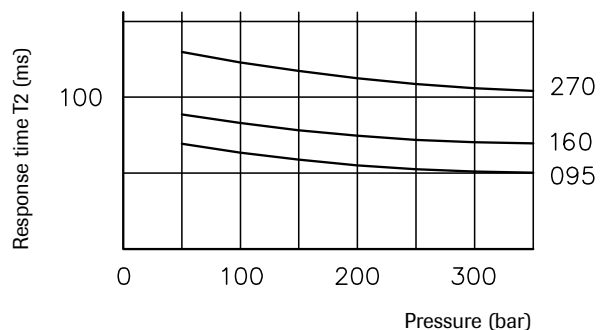

- S_s = Regulating distance actuator
- T_u = Delay < 3 ms
- T₁ = Response time min to max
- T₂ = Response time max to min
- p = Pressure

LS-line min. length 1.5 m, min. internal diameter 12 mm



Basic pumps: SVH 062

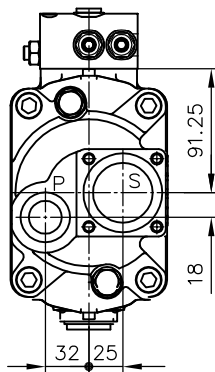
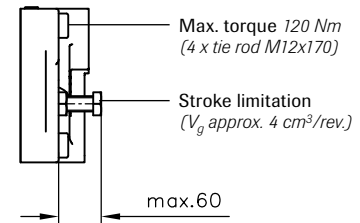
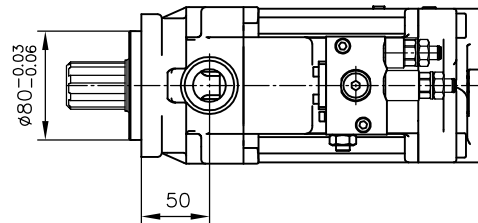
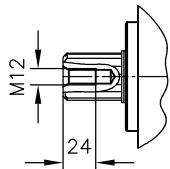
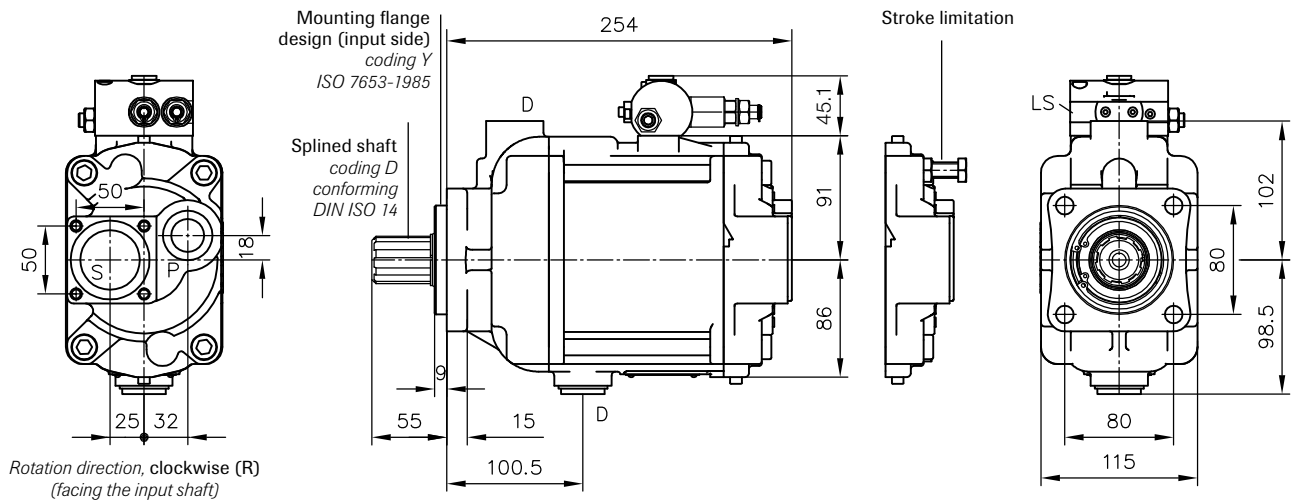

Rotation direction, counter clockwise (L)
(facing the input shaft)

Coding UNF ports conforming SAE J 514:

P = 1 1/16-12 UN-2B

S = Flange, suction port

D = 1 1/16-12 UN-2B

LS = G 1/4 (ISO 228/1 (BSPP)) with adaptor for 7/16-20 (SAE-4)

Ports (ISO 228/1 (BSPP)):

P = Pressure outlet G 3/4

S = Flange, suction port

D = Case drain G 3/4

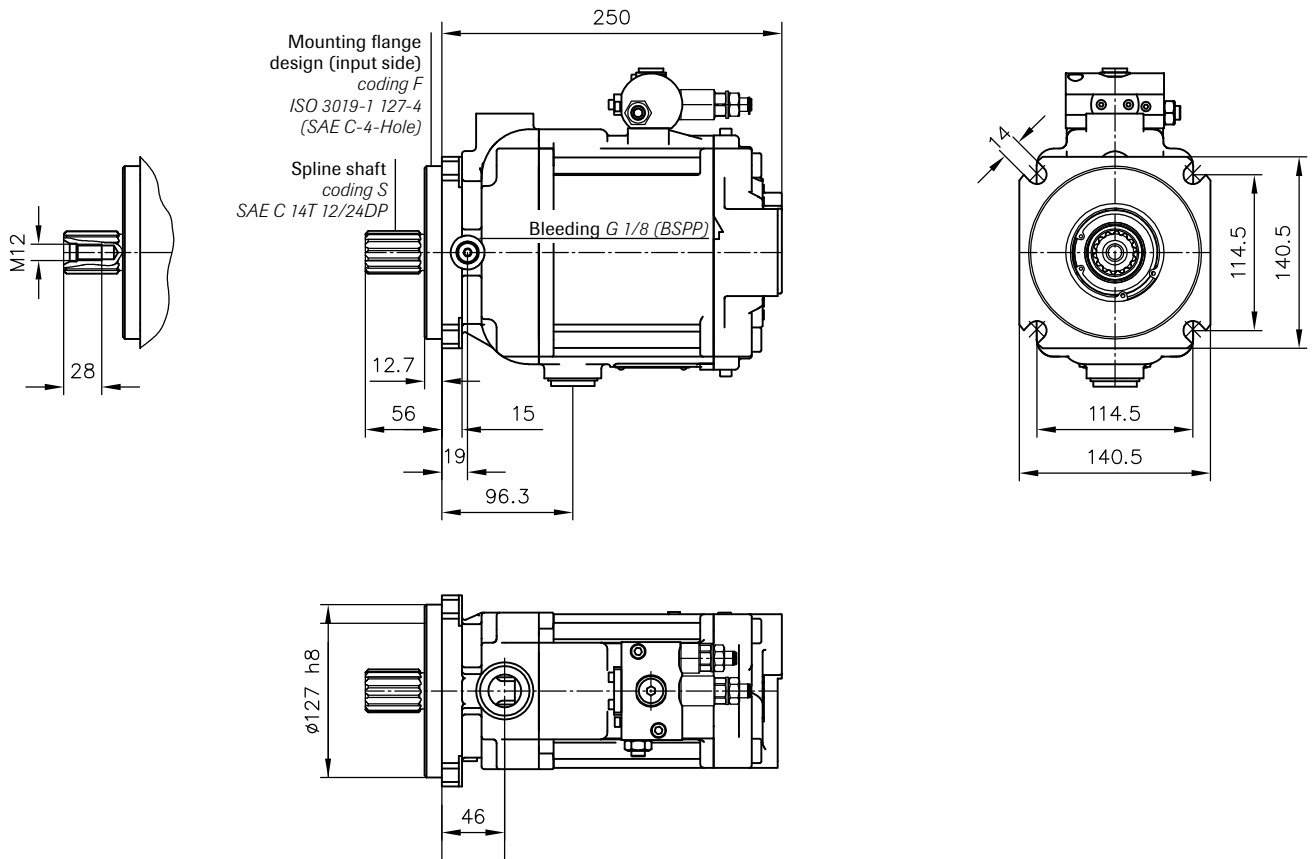

Additional input shaft designs

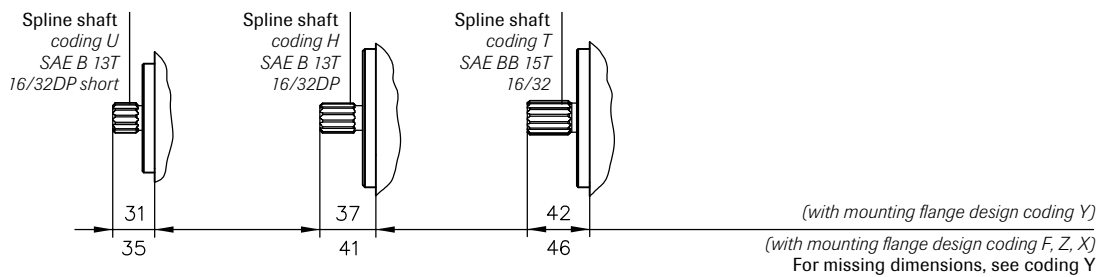

Additional mounting flange design

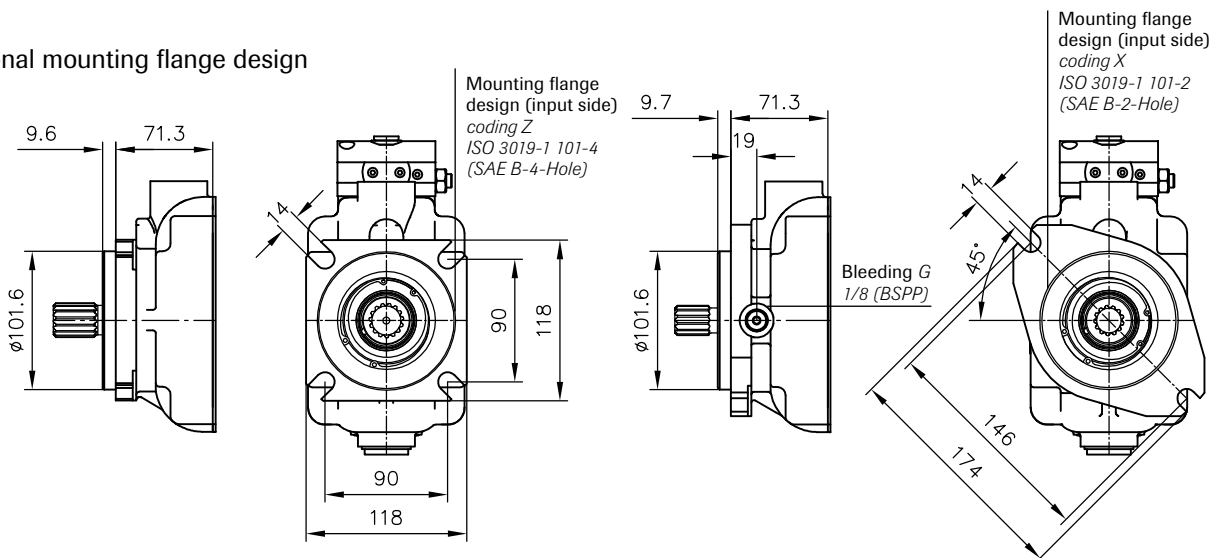

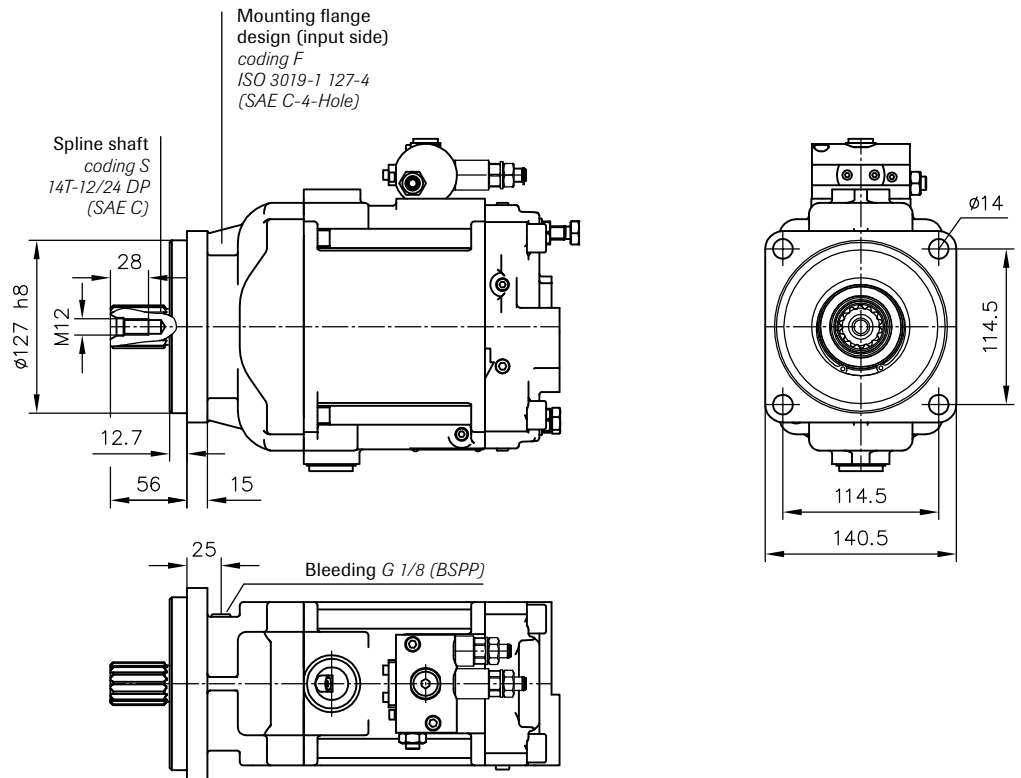

SVH 092 with thru-shaft

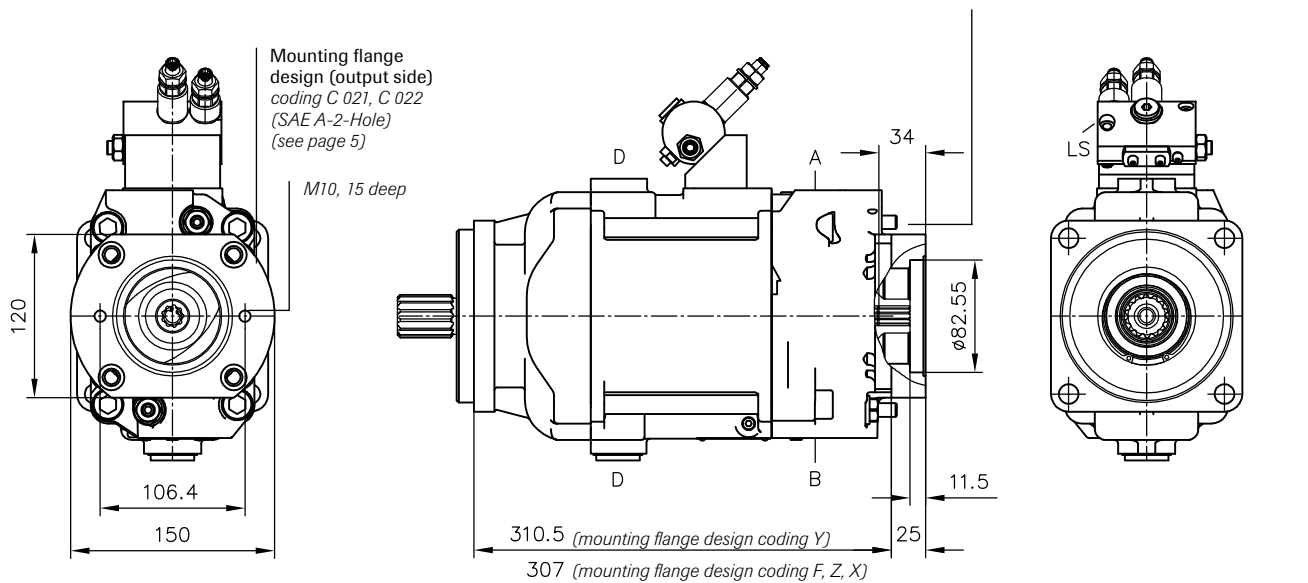

Right hand
A Suction port
B Pressure outlet

Left hand
A Pressure outlet
B Suction port

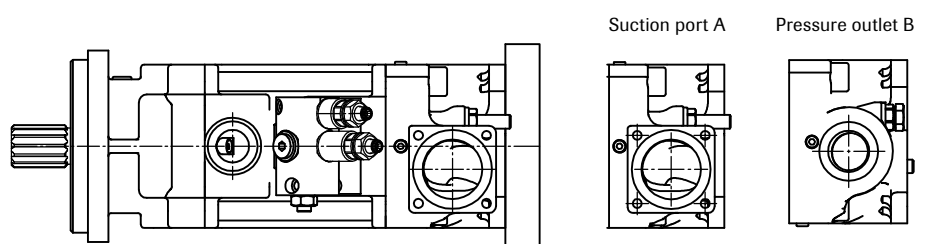

For port sizes, see page 10

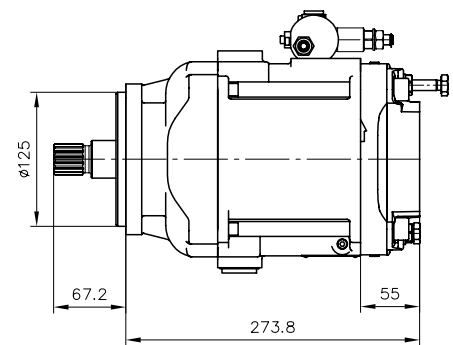
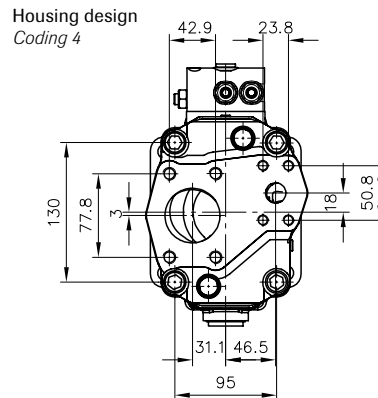
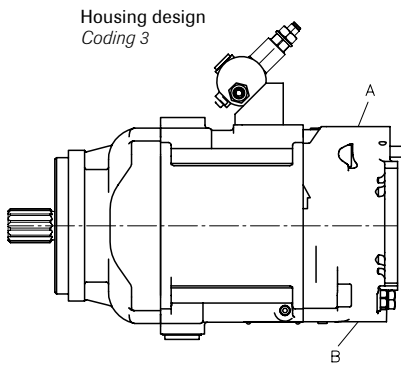
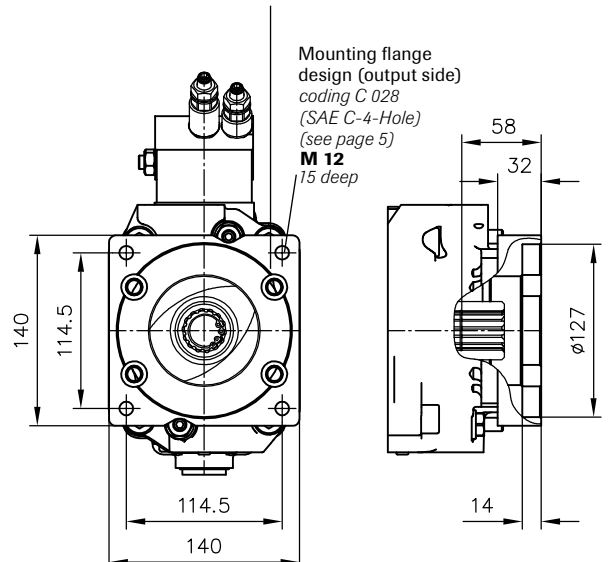
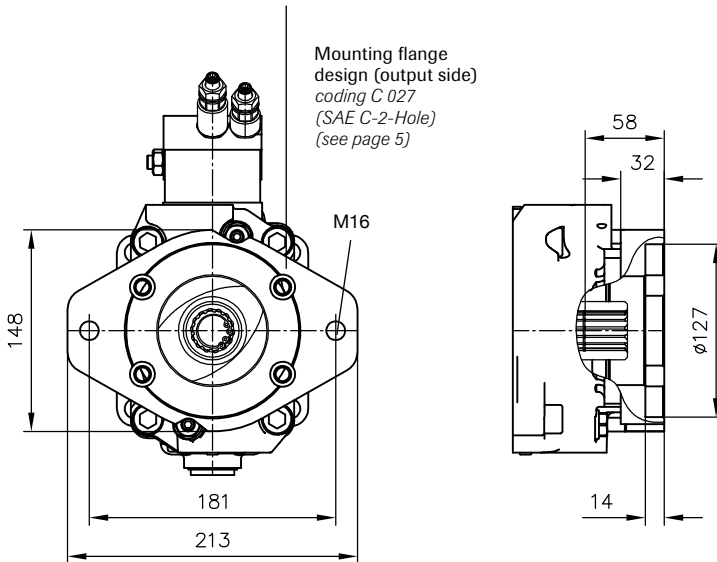
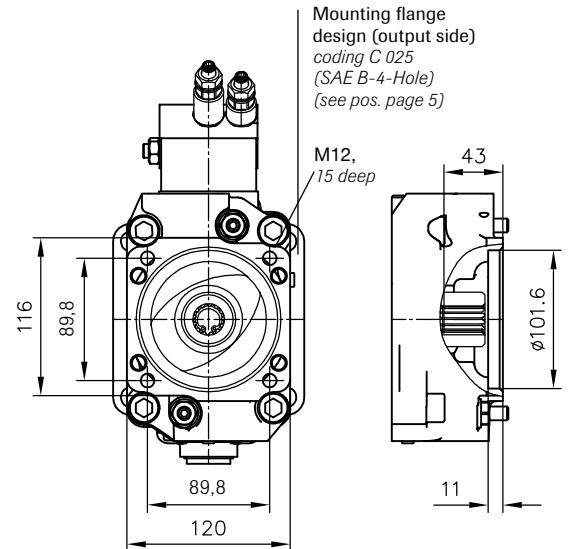
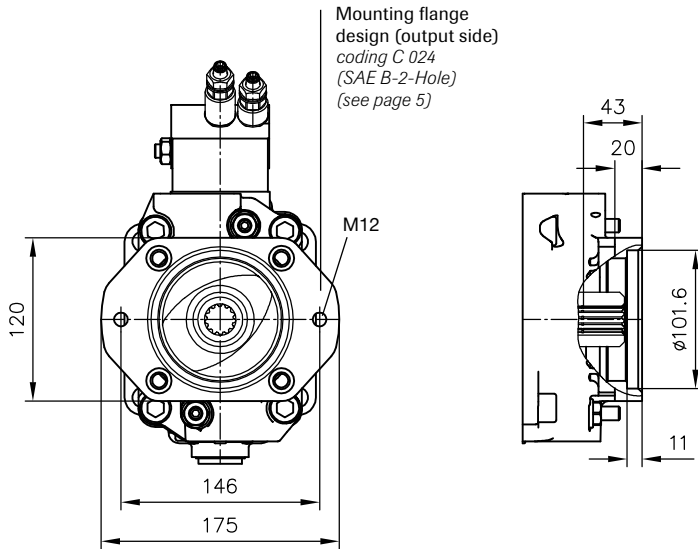

For available mounting flange designs (output side) and coupling sleeves, see page 5

Portar

P=	SAE 3/4" (6000 psi)
S=	SAE 2" (3000 psi)



SVH 112

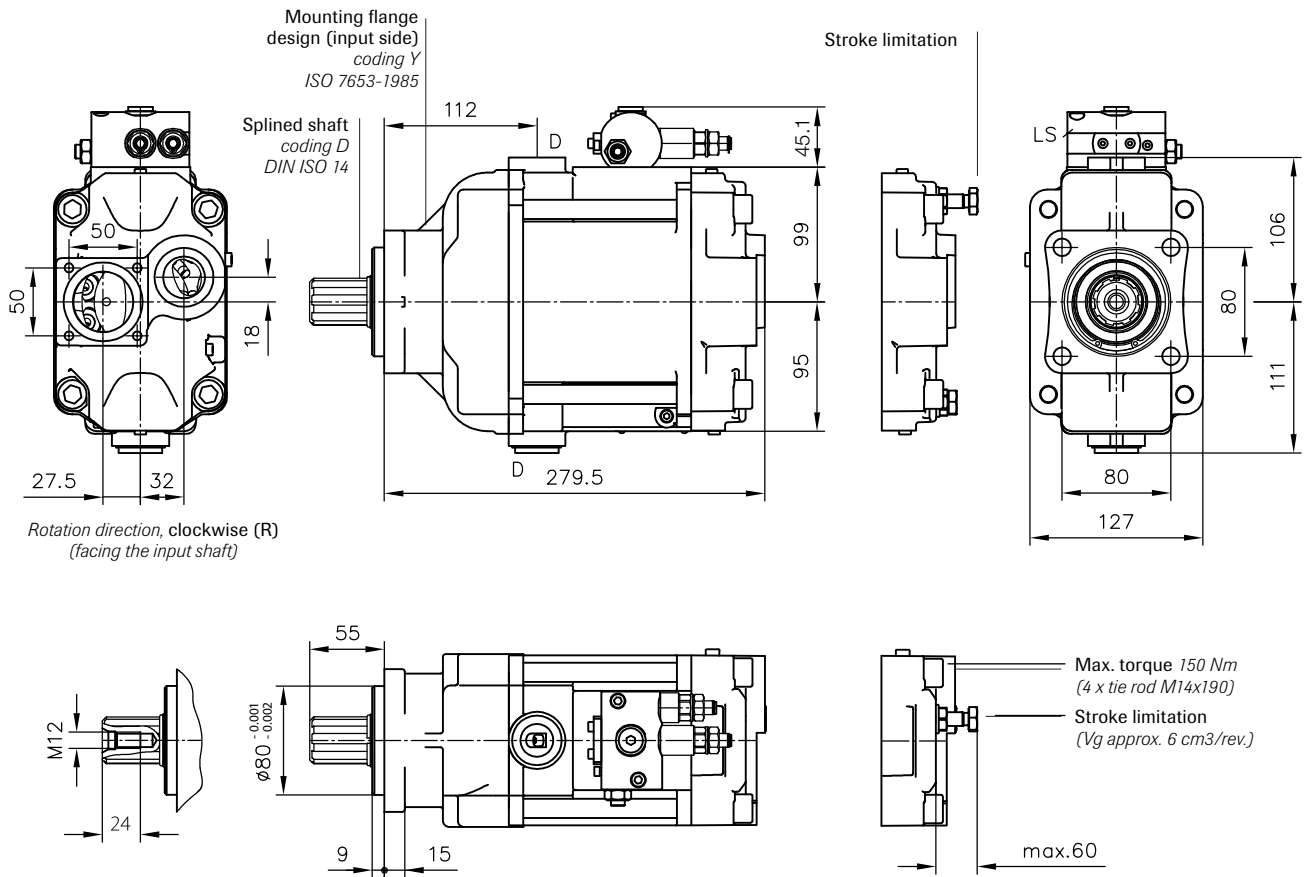

Additional input shaft designs and mounting flange design

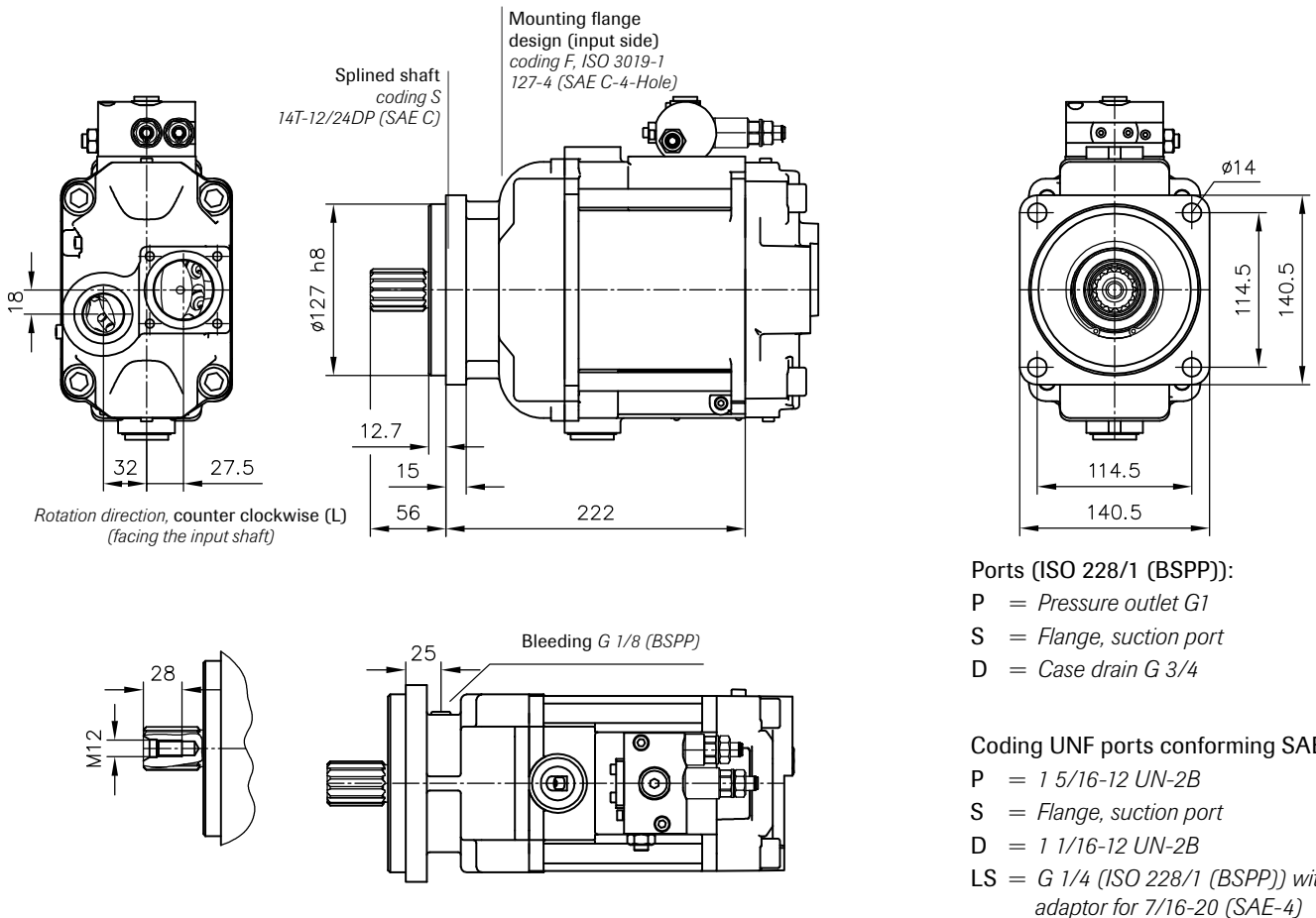



Additional input shaft designs

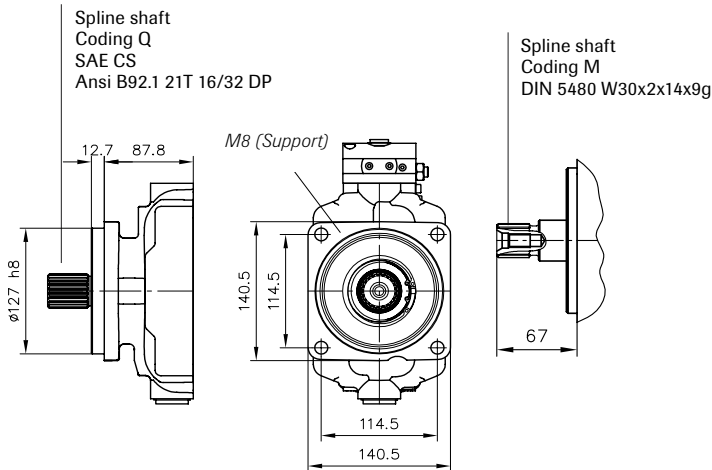

Additional mounting flange design

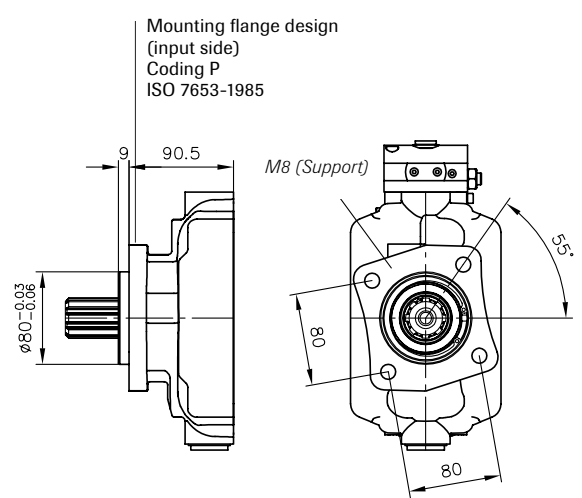

SVH 112 with thru-shaft

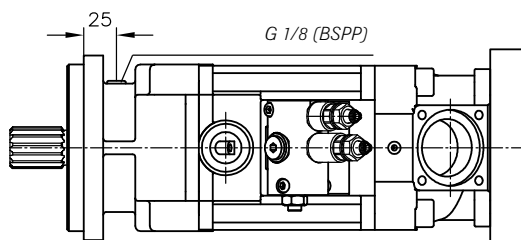
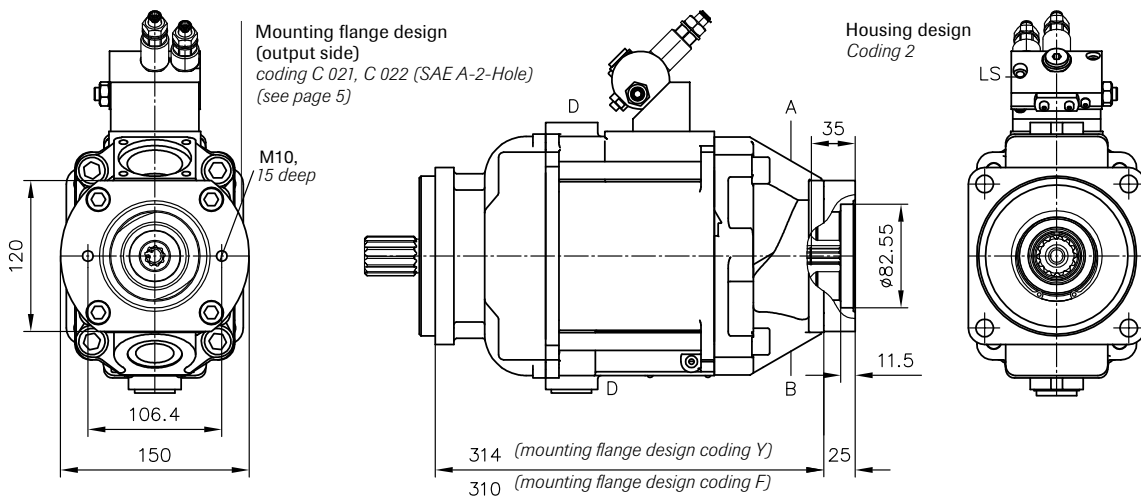

Suction port A

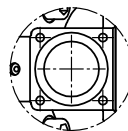

- Right hand
- A Suction port
- B Pressure outlet

Pressure outlet B

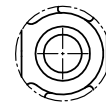

- Left hand
- A Pressure outlet
- B Suction port

For port sizes, see page 13

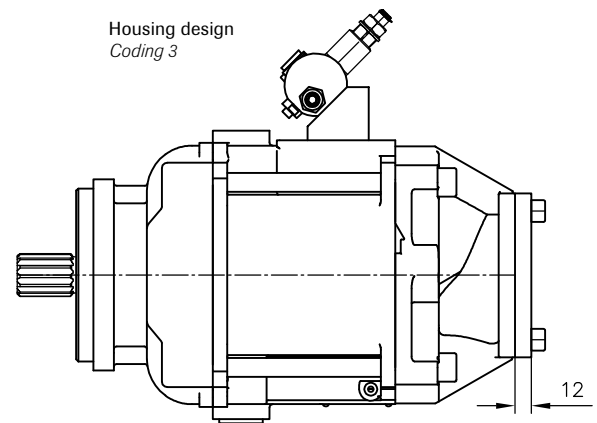
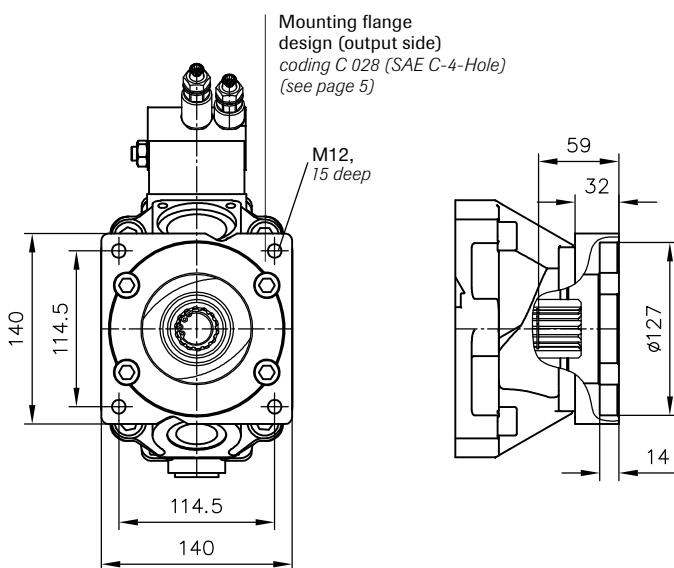
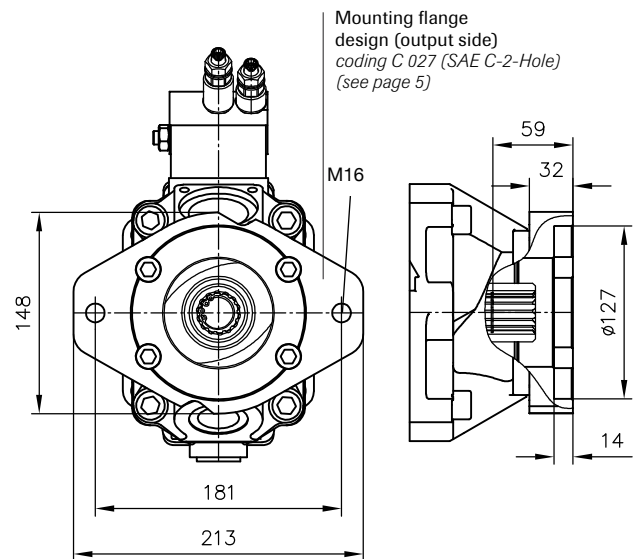
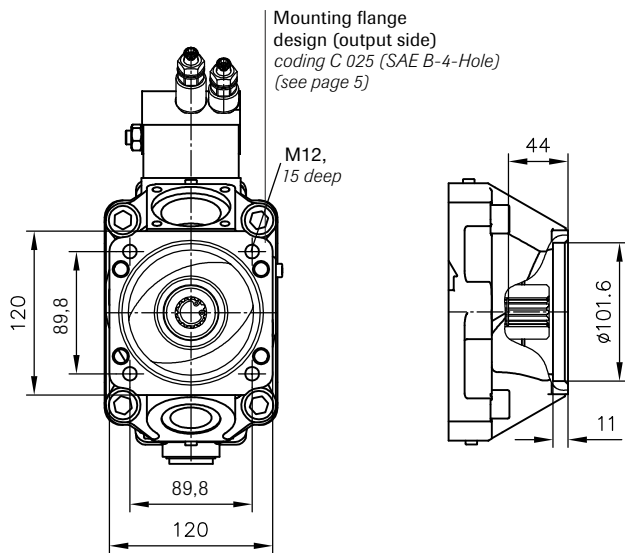
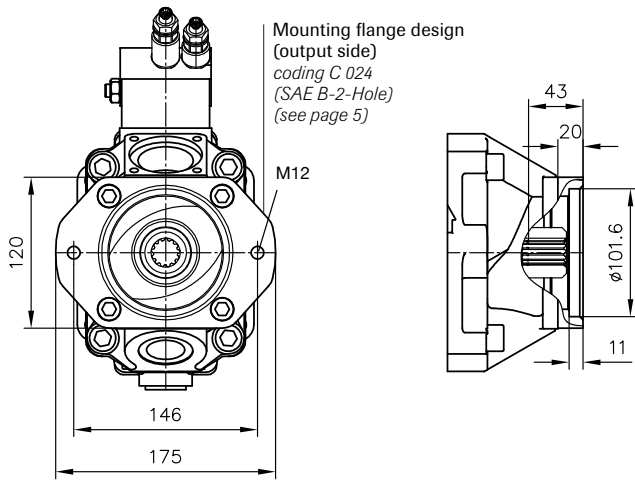



SVH 130

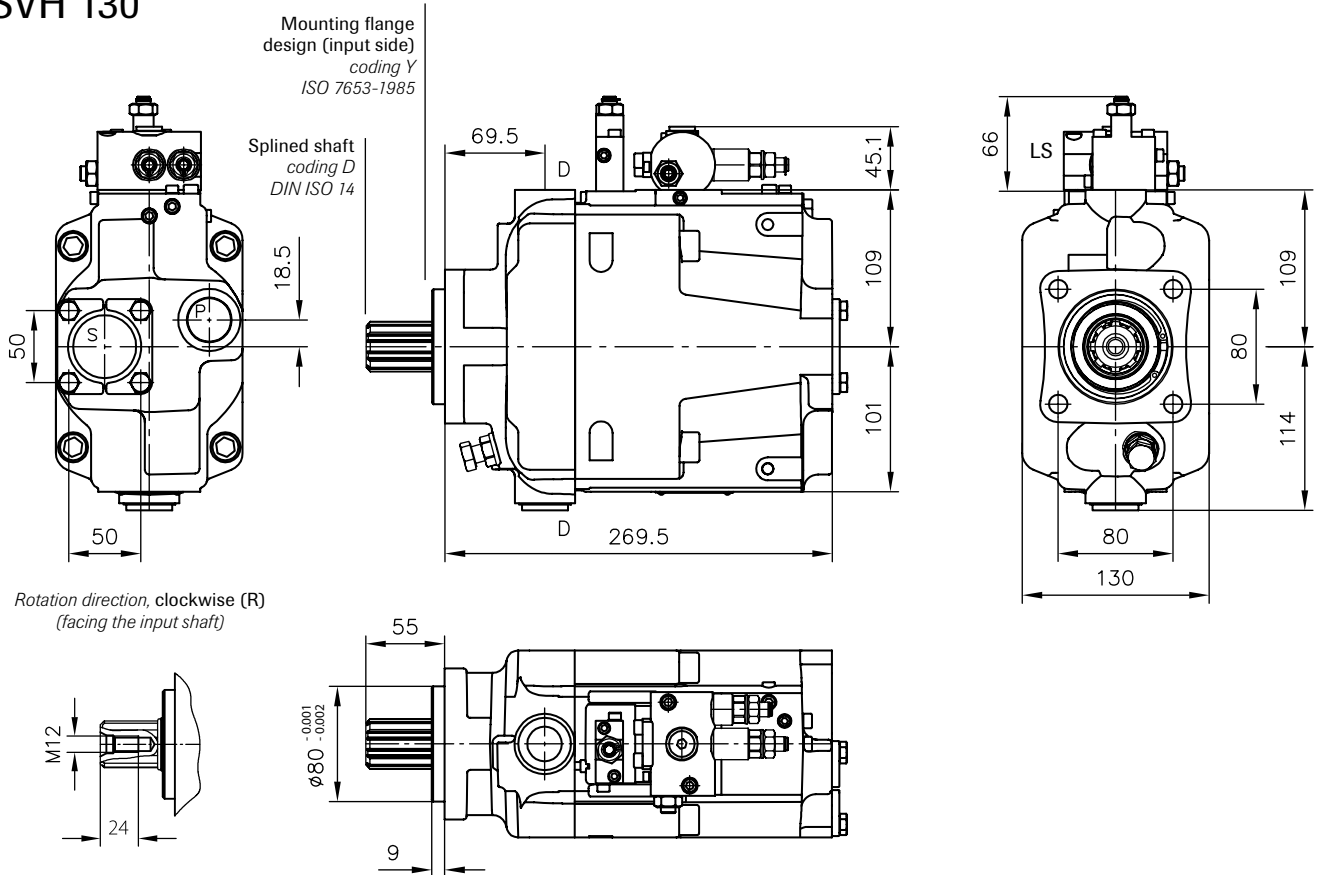

Additional input shaft designs and mounting flange design

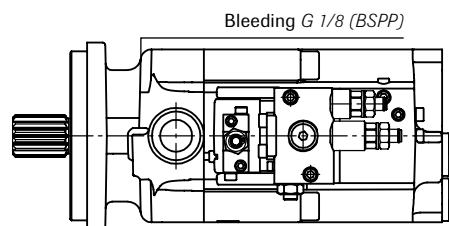
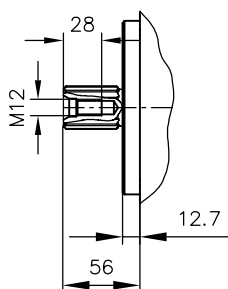
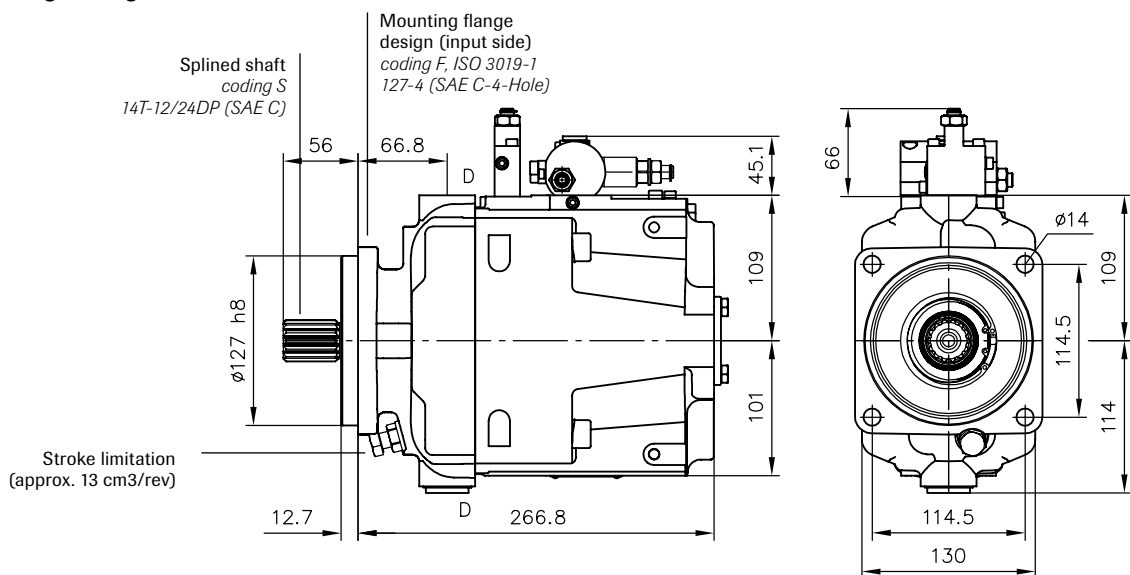

Ports (ISO 228/1 (BSPP)):

- P = Pressure outlet G 1
- S = Flange, suction port
- D = Case drain G 3/4

Coding UNF ports conforming SAE J 514:

- P = 1 5/16-12 UN-2B
- S = Flange, suction port
- D = 1 1/16-12 UN-2B
- LS = G 1/4 (ISO 228/1 (BSPP))
with adaptor for 7/16-20 (SAE-4)



Additional input shaft designs

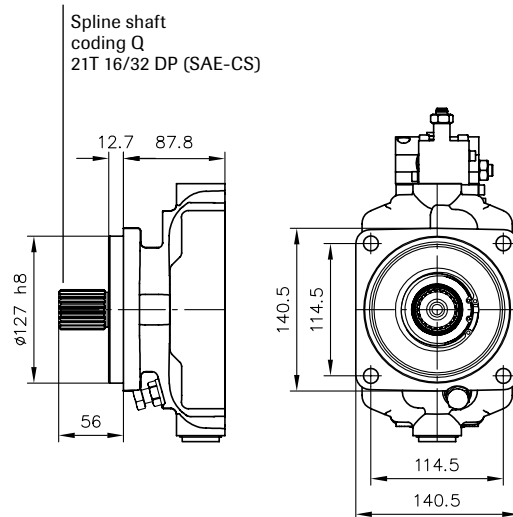

Additional mounting flange design

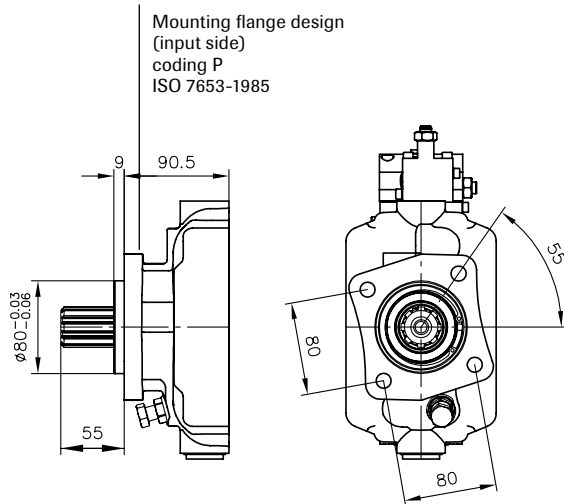



SVH 130 with thru-shaft

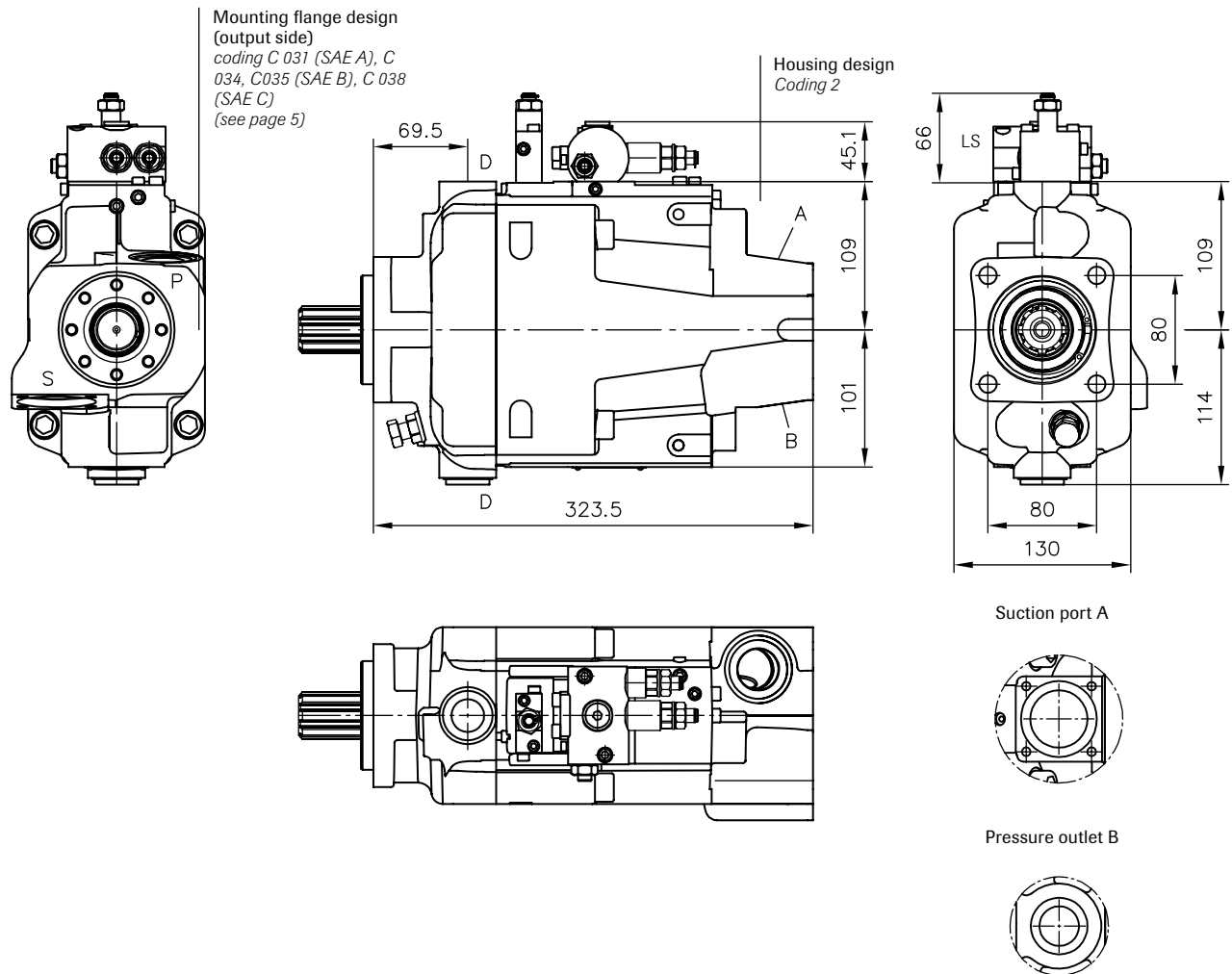

Right hand

A Suction port

B Pressure outlet

Left hand

A Pressure outlet

B Suction port

For port sizes, see page 13

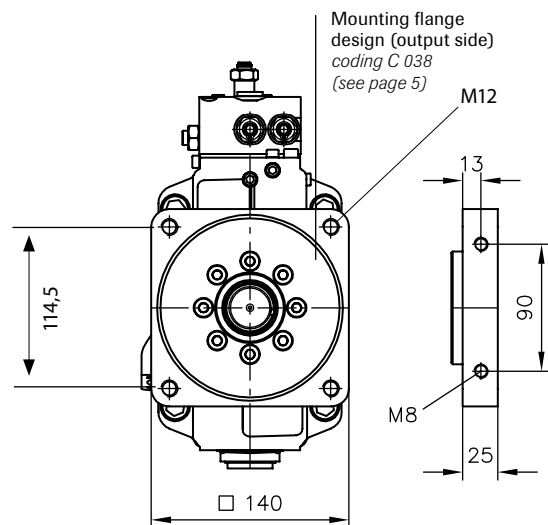
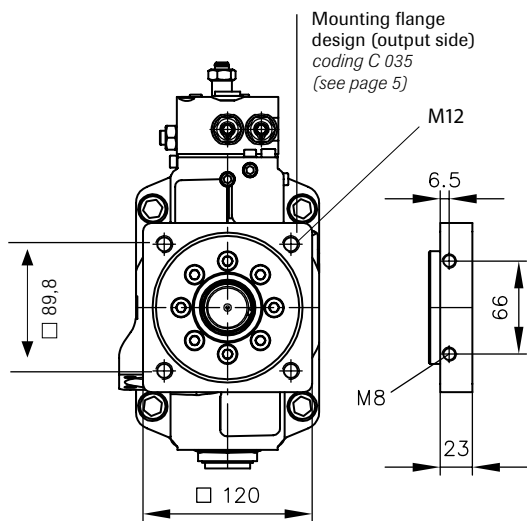
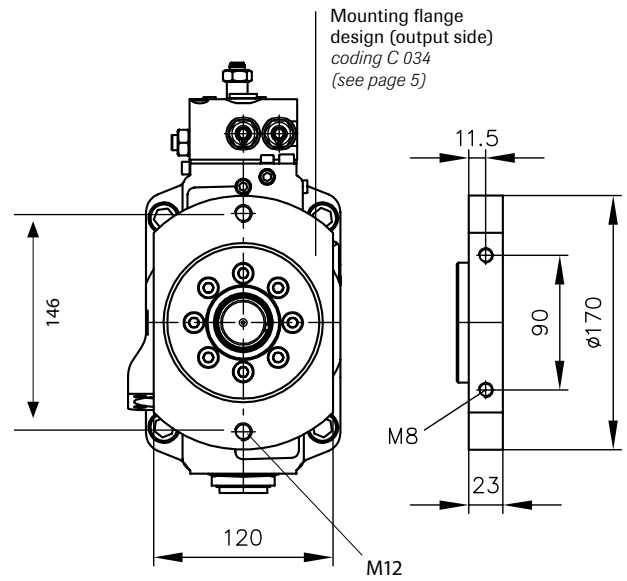
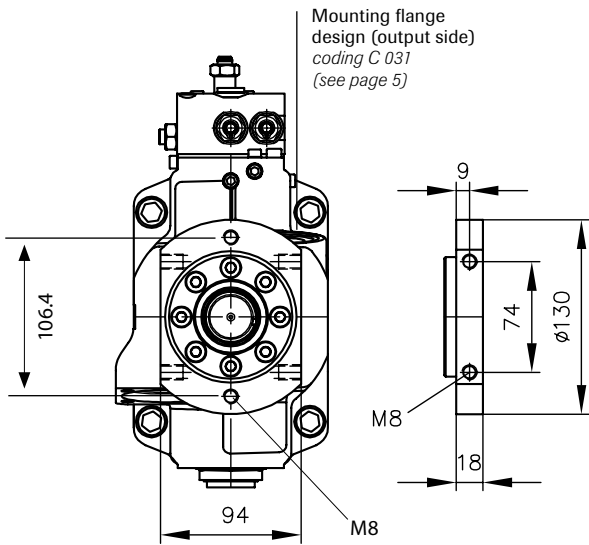

**WARNING**

When the pump is running:

1. *Do not touch the pressure hose*
2. *Watch out for rotating parts*
3. *The pump and hoses may be hot*

*Sunfab reserves the right to make changes in design and dimensions without notice. Printing and typesetting errors reserved.
© Copyright 2015 Sunfab Hydraulics AB. All Rights Reserved.*