

HYDROPNEUMATIC BLADDER ACCUMULATORS



WARNING
NEVER FILL WITH OXYGEN. DANGER OF
EXPLOSION. PRESSURE SHOULD NOT BE LESS
THAN WORKING PRESSURE AND NOT MORE
THAN MAXIMUM PRESSURE. -3) MAKE SURE THE
PRESSURE BEFORE DISASSEMBLING. SEE INSTRU-
CTIONS. -4) DO NOT TAMPER WITH THE BOTTLE.



ATTENZIONE
-1) PRECARICARE CON AZOTO
-2) LA PRESSIONE
INFERIORE A 0,4 LA PRESSIONE
A 9/10 LA PRESSIONE
CUMULATORE ASSICURARE
LE CONDIZIONI DI USO E MANUTENZIONE

Content

	Page
1. General	3
2. Main applications	4 - 5
3. Accumulator selection	6 -17
4. High pressure range	18 - 19
5. Low pressure / Pulsation damper	20 -21
6. ASME U.S. - Range	22
7. Additional gas bottles	23
8. Flanged fluid connections	24
9. Pulse damper connections	25
10. Relief valves - fluid side	26
11. Safety valves gas and fluid sides	27
12. Connection and protection blocks series B10-B20	28 - 29
13. Connection and protection blocks series BS25-BS32	30 - 31
14. Connection blocks series "BC" - gas side	32
15. Support equipments	33
16. Pre-loading and checking set	34 - 35
17. Spare bladders for accumulators	36 - 37
18. Accumulator stations	38
19. Installation	39
20. Checking and charging	40
21. Servicing and maintenance	41 - 42
22. Branches and representatives all over the world	

1.1 Definition and operation

The hydropneumatic accumulator is a device designed specifically for the storage of liquids under pressure. As liquids are, for all practical purposes, incompressible, the objective is achieved by utilising the compressibility of gases (fig. 1):

- A) A flexible separator bladder is fitted into a pressure vessel (accumulator shell).
- B) Through a special valve an inert gas (nitrogen) is introduced into the bladder with pressure P_0 . The bladder expands, filling the entire volume V_0 of the accumulator shell.
- C) When circuit pressure P_1 is higher than the gas precharge pressure P_0 , the liquid valve opens, and the bladder is compressed reducing the gas volume to V_1 .
- D) When the liquid pressure rise to P_2 , the volume of gas reduces to V_2 with an attendant rise in pressure, thus balancing the liquid pressure.

This means that the accumulator has been pressurised $\Delta V = V_1 - V_2$ and a potential energy has been created to be utilised as desired (refer to section 2).

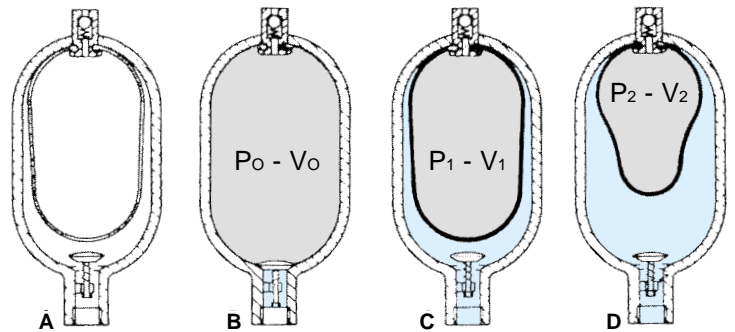

fig. 1

1.2 Construction features

The EPE Bladder Accumulator comprises a steel shell in which is fitted a bladder complete with a gas valve and fluid port with the poppet valve (fig. 2):

- **The shell** is a pressure vessel forged or fabricated from high grade steel designed and manufactured to meet the relevant international standards. For special applications various surface coatings are available as well as a stainless steel construction.
- **The bladder**, which separates the gas from the liquid, is made in nitrile rubber in the standard version. Bladders in butyl, neoprene, ethylene-propylene etc. are available for special uses. The main feature of the EPE bladder, which makes it unique, is the special manufacturing process thanks to which it is produced in one single piece without joints, even in the larger sizes, so as to avoid all the problems which poor gluing may involve. Another advantage of the EPE bladder is the gas valve which, not being vulcanised to the bladder, can be fit to it and removed simply and safely. For this reason the same bladder can be supplied with gas valve in different versions, or the valve can be reused, thus reducing the cost of spare parts.
- **The gas valve** is connected to the bladder by a rubber coated washer to ensure a gas tight joint and a non return valve is incorporated for bladder inflation. The bladder, complete with the gas valve, is fixed to the accumulator shell by a lock nut, and the assembly is protected by a cover.
- **The fluid port valve** prevents the bladder from extruding into the fluid port and, at the same time, allows the liquid to flow. In the high pressure range is used a poppet valve, while in the low pressure range is used a drilled disc. In the latter case the precharge pressure should not exceed 15 bar.

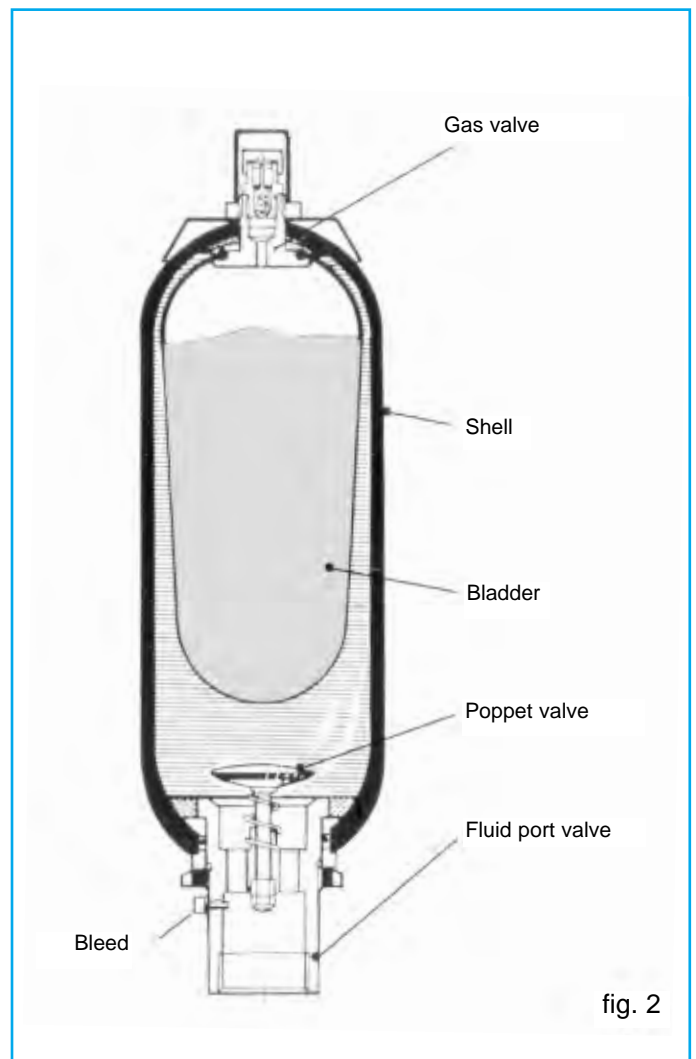

fig. 2

2.1 Fluid power storage

In the case of hydraulic circuits where a large flow rate is required for a short period, alternating with a low or no flow condition, the use of an accumulator allows smaller pumps and motors to be used, thus reducing both installation and operating costs.

The operation cycle shown in fig. 3 would require a pump having a capacity Q_2 . If an oleo-pneumatic accumulator is used, it is possible to store oil during the time periods $(t_2 - t_1)$ and $(t_4 - t_3)$ when requirement is very low or zero, and to reutilize it during t_1 and $t_3 - t_2$, when the required flow rate is higher than pump capacity Q_1 .

This pump must be selected in order to have the volumes $V_1 + V_2 \leq V_3 + V_4$.

There are many potential applications including thermoplastic extruders, transfer lines in steel mills, rolling mills, machine tools, hydraulic presses etc.

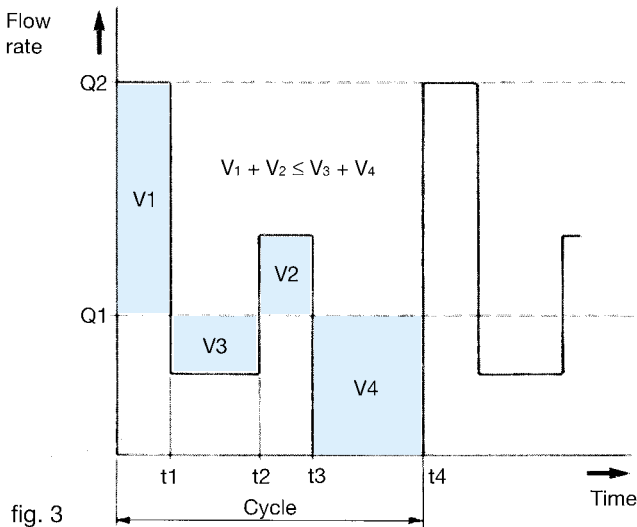

fig. 3

2.2 Pulsation damper

By virtue of their design both piston and diaphragm pumps create pulsation or pressure peaks during operation, this being undesirable and detrimental for both the smooth operation and operational life of components.

The fitting of a bladder accumulator near the pressure line of the pump, will damp the pulsations to an acceptable level (fig. 4). Typical applications are: dosing pumps, pumps with a small number of pistons, etc.

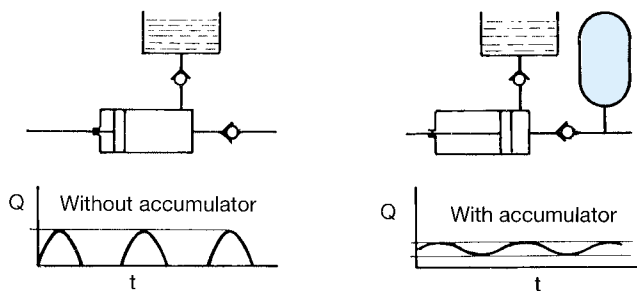

fig. 4

2.3 Emergency energy reserve

In the case of a sudden power loss, e.g. pipe or joint failure, pump breakdown etc. the accumulator can provide sufficient energy to complete an operational cycle or to allow actuators, valves etc. to re-set to a "safe" position, and so prevent damage to equipment or product.

Besides, the availability of such an emergency power source, is essential in case where a hydraulic power supply is required for closing a safety door, electrical switch, safety valve, emergency brakes etc.

Another typical application is the emergency supply of fuel oil to power plant burners.

Fig. 5 illustrates that a failure at "B" causing a loss of energy can be offset operating manually the electro valve "A" thus utilising the potential energy of the accumulator.

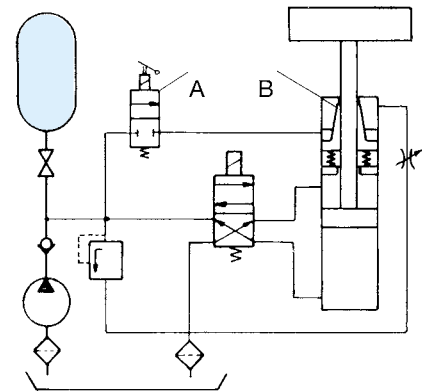

fig. 5

2.4 Volume compensator

In a closed hydraulic circuit a rise in temperature can cause an increase in pressure due to thermal expansion.

An accumulator installed in the line will protect the valves, gaskets, pressure gauges etc. Common applications are found in refineries and pipelines.

2.5 Pressure compensator

When a constant static pressure is required for a long period, an accumulator is indispensable as it will compensate for pressure loss due to seepage through joints, seals etc. as well as balancing pressure peaks which may occur during the operating cycle. Typical applications are found in closing systems, fig. 6, loading platforms, curing presses, machine tools, lubricating systems, etc.

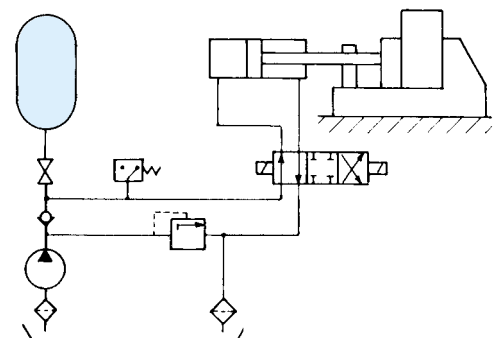

fig. 6

2.6 Counter balancing

The balancing of a force or weight can be achieved by using hydraulic pistons driven by an accumulator, thus avoiding the use of counterweights with attendant dimensional and weight saving. Typical applications are in machine tools (fig. 7), hoists etc.

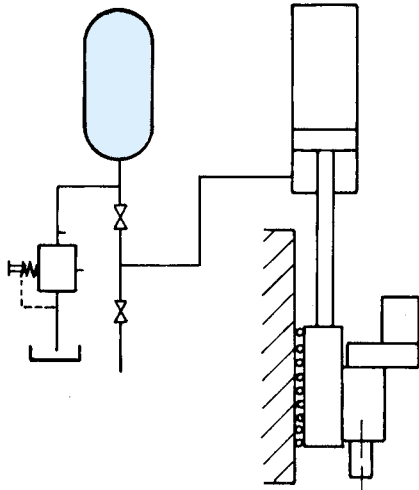

fig. 7

2.7 Hydraulic line shock damper

Rapid valve closure can produce shock waves (water hammer) resulting in overpressurisation of pipes, joints, valves etc. The use of a suitable accumulator can neutralize or significantly reduce the shock. Typical applications are water (fig. 8), fuel and oil distribution circuits, washing equipment etc.

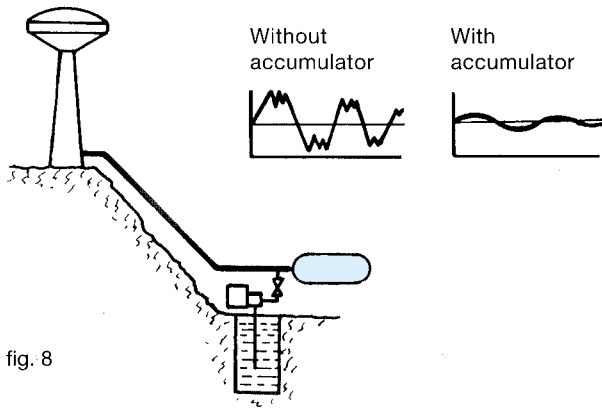

fig. 8

2.8 Shock absorber

Mechanical shocks in hydraulically driven equipment can be absorbed by accumulators. Possible applications are in drive and suspension systems for fork-lifts, mobile cranes, agricultural and civil engineering machinery etc. (fig. 9)

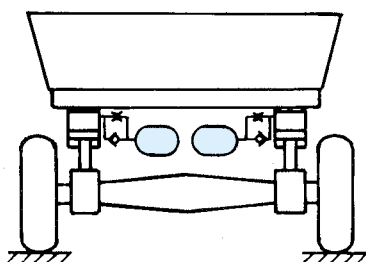

fig. 9

2.9 Hydraulic spring

The accumulator can be used with advantage as an alternative to mechanical springs, e.g. deep drawing (fig. 10). The thrust can be easily controlled with great accuracy over a wide range of pressures by oil pressure control without the need of springs or supports.

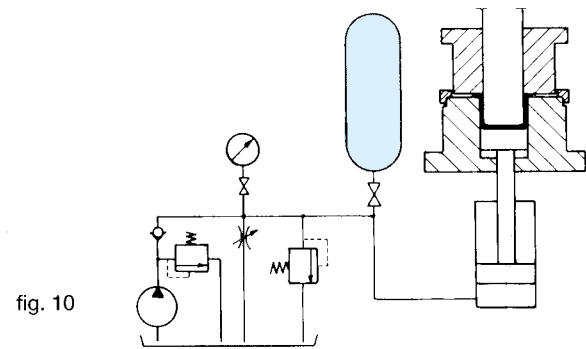

fig. 10

2.10 Fluid separator (transfer barrier)

Fundamentally the accumulator separates two fluids (in the case of hydraulic applications nitrogen and oil). However, the accumulator can be used when pressure has to be transferred between two incompatible fluids, hence the name TRANSFER. Fig. 11 is a simplified diagram for a fatigue test of a vessel "S" using water. The initial pressure pulse is generated by piston pump "P" using oil. An equal volume and pressure is transferred to the water into the vessel by the accumulator. Many similar applications are found in the petro-chemical industries.

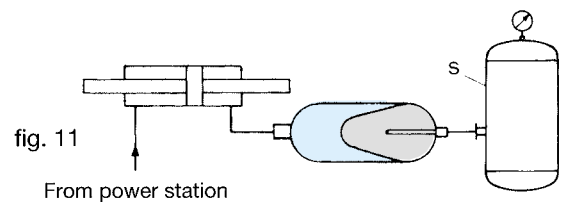

fig. 11

From power station

Fig. 11A shows a typical application of TRANSFER between a liquid and a gas by using an **accumulator with additional gas bottles**. This application is especially convenient in those cases where the amount of liquid required is quite large compared to the small difference between the operating pressures. To reduce the total capacity, therefore the number of accumulators required, the volume of available gas is increased by connecting the accumulators to additional gas bottles (refer to Section 3.11).

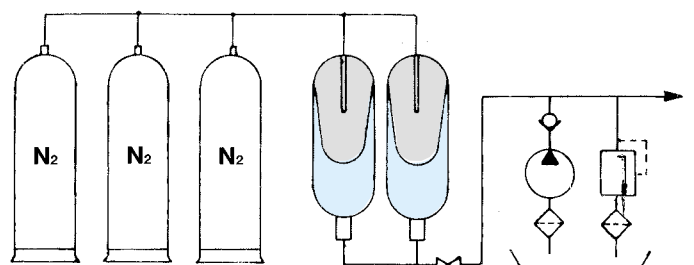

fig. 11A

3.1 Method of selection

Many parameters are involved in the selection of an accumulator, the most important are:

a) Minimum working pressure P_1 and maximum pressure P_2

The value of P_2 must be lower or equal to the maximum authorised working pressure of the accumulator to be chosen for safety reasons.

The value of P_1 is found in the ratio $\frac{P_2}{P_0} \leq 4$

which will give optimum efficiency and operating life.
(For calculation of pre-loading pressure P_0 , refer to Section 3.2)

b) Volume ΔV of liquid to be stored or utilised

This information is required in addition to the maximum and minimum pressure values for the correct sizing of the accumulator.

c) Method and Application

It is important to establish if the gas during operation is subjected to isothermal or adiabatic conditions.
If compression (or expansion) is slow, (more than 3 minutes) so that the gas maintains approximately constant temperature, the condition is **ISOTHERMAL** (examples: pressure stabilisation, volume compensation, counter balancing lubrication circuits). In all other cases (energy accumulator pulsation damper, shock wave damper, etc.) owing to high speed transfer heat inter-change is negligible, and therefore the condition is **ADIABATIC**. Approximately the adiabatic condition will exist when the compression or expansion period is less than 3 minutes.

d) Operating temperature

Operating temperature will determine the choice of materials for the bladder and steel and will also have an influence on the pre-loading pressure, and consequently on the accumulator volume.

e) Type of Liquid

This will determine the choice of materials.

f) Maximum required flow rate

For the same ΔV required, the size or the accumulator connection can be influenced by the immediate flow rate necessary.

g) Location

It is important to know the eventual destination of the accumulator in order that the design can meet local design and test parameters.

Based on the foregoing, it is possible to choose a suitable accumulator for the specific application required.

3.2 Gas precharge pressure

The accurate choice of precharge pressure is fundamental in obtaining the optimum efficiency and maximum life from the accumulator and its components. The maximum storage (or release) of liquid is obtained theoretically when the gas precharge pressure P_0 is as close as possible to the minimum working pressure. For practical purposes to give a safety margin, and to **avoid valve shut-off during operation**, the value (unless otherwise stated) is:

$$P_0 = 0.9 P_1$$

The limit values of P_0 are: $P_0 \text{ min} \geq 0.25 \times P_2$
 $P_0 \text{ max} \leq 0.9 P_1$

Special values are used for:

Pulsation damper and shock absorber

$$P_0 = 0.6 \div 0.75 P_m \quad \text{or} \quad P_0 = 0.8 P_1$$

where:

P_m = average operation pressure.

Hydraulic line shock damper

$$P_0 = 0.6 \div 0.9 P_m$$

where:

P_m = average working pressure with free flow.

Accumulator + additional gas bottles

$$P_0 = 0.95 \div 0.97 P_1$$

Value P_0 is valid for **MAXIMUM OPERATING TEMPERATURE REQUIRED BY THE USER**.

Checking or pre-loading of accumulator takes place generally at a different temperature from the operating one θ_2 , so that the value P_0 at the checking temperature θ_c , becomes:

$$P_{0c} = P_0 \frac{\theta_c + 273}{\theta_2 + 273}$$

for $\theta_c = 20^\circ\text{C}$ we have:

$$P_{0(20^\circ\text{C})} = P_0 \frac{293}{\theta_2 + 273}$$

NOTE Precharge pressure of accumulators directly supplied from the factory is referred to a temperature of 20°C .

3.3 Calculation principles

Compression and expansion of gas inside the accumulator takes place according to the Boyle-Mariotte law regarding the status change in the perfect gases:

$$P_0 \cdot V_0^n = P_1 \cdot V_1^n = P_2 \cdot V_2^n$$

The PV diagram Fig. 12 shows the “pressure-volume” relationship inside the accumulator.

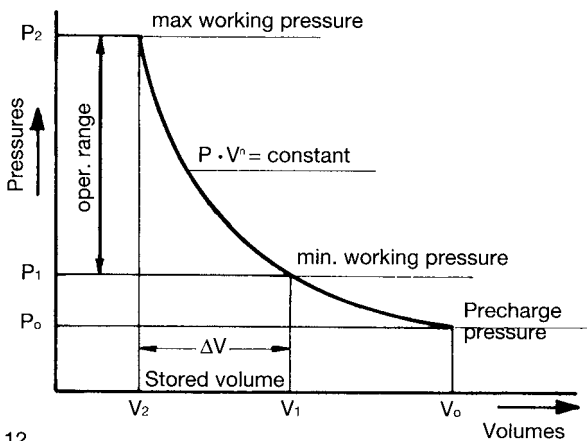

fig. 12

where:

V_0 = Nitrogen pre-charge volume at pressure P_0 (litres).
It is the maximum volume of gas which can be stored in the accumulator and it is equal to, or slightly lower than, nominal capacity.

V_1 = Nitrogen volume at pressure P_1 (litres).

V_2 = Nitrogen volume at pressure P_2 (litres).

ΔV = Volume of discharged or stored liquid (litres).

P_0 = Precharge pressure (bar).

P_1 = Minimum operating pressure (bar).

P_2 = Maximum operating pressure (bar).

n = Polytropic exponent.

The curve of volume variation as a function of pressure is dependant on the exponent n , which for nitrogen is contained between the limit values:

$n = 1$ In case compression or expansion of nitrogen takes place so slowly that a complete interchange of heat is allowed between gas and environment, that is at constant temperature, **the condition is isothermal.**

$n = 1,4$ When operation is so quick that no interchange of heat can take place, **the condition is adiabatic.**

In fact, these are theoretical and not practical conditions. It is however possible to state, with reasonable accuracy, that when an accumulator is used as a volume compensator, leakage compensator, the condition is isothermal. In the remaining applications, such as energy accumulator, pulsation damper, emergency power source, dynamic pressure compensator, water hammer absorber, shock absorber, hydraulic spring, etc., it is possible to state, with reasonable accuracy, that the condition is adiabatic.

When is required a more accurate calculation, is possible to use intermediate values of n as function of t , that is of expansion or compression time, according to diagram (fig. 13):

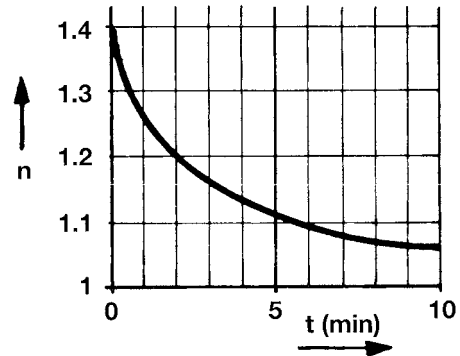

fig. 13

Note: In all calculations, pressures are expressed as **absolute bar** and **Temperature as Kelvin degrees.**

3.4 Volume calculation (isothermal condition)

When $n = 1$, the Boyle-Mariotte law becomes

$$P_0 \cdot V_0 = P_1 \cdot V_1 = P_2 \cdot V_2$$

so that:

$$V_1 = V_0 \cdot \frac{P_0}{P_1} \text{ and } V_2 = V_0 \cdot \frac{P_0}{P_2}$$

The difference between volume V_1 (at minimum operating pressure) and V_2 (at maximum operating pressure) gives the amount of stored liquid (See Section 1.1):

$$\Delta V = V_1 - V_2 = V_0 \frac{P_0}{P_1} - V_0 \frac{P_0}{P_2}$$

so that:

$$\Delta V = V_0 \left(\frac{P_0}{P_1} - \frac{P_0}{P_2} \right)$$

Accumulator volume V_0 will be:

$$V_0 = \frac{\Delta V}{\left(\frac{P_0}{P_1} \right) - \left(\frac{P_0}{P_2} \right)}$$

which could be also written:

$$V_0 = \frac{\Delta V}{P_0 \left(\frac{1}{P_1} - \frac{1}{P_2} \right)}$$

which shows that accumulator volume increases when ΔV is increasing, when P_0 is decreasing and when the difference between the two operation pressures P_1 and P_2 is decreasing. The values of ΔV and V_0 could be deduced more quickly from the diagrams on pages 12 and 13.

3.4.1 Volume compensator (isothermal)

A typical example of calculation in the isothermal condition is when the accumulator is used as a volume compensator.

Assume a tube with ØI.D.=77,7 mm, 120 m long and inside which some oil is flowing at a pressure of 10 bar and a temperature of $\theta_1 = 10^\circ\text{C}$ and $\theta_2 = 45^\circ\text{C}$.

Permissible change of pressure $\pm 8\%$.

The volume variation will be:

$$\Delta V = V_T (\theta_2 - \theta_1) (\beta - 3\alpha) \\ = 596 (45 - 10) (0.00095 - 3 \cdot 0.000012) = 18,2 \text{ lt.}$$

where:

V_T = piping volume (litres).

θ_2 = max. temperature ($^\circ\text{C}$).

θ_1 = min. temperature ($^\circ\text{C}$).

β = cubic expansion coefficient of fluid ($\frac{1}{^\circ\text{C}}$).

α = linear expansion coefficient of piping ($\frac{1}{^\circ\text{C}}$).

P_1 = min. permissible operating pressure (bar).

P_2 = max. permissible operating pressure (bar).

where:

$$P_o = 0.9 \cdot 10 = 9.0 \text{ bar}$$

$$P_1 = -8\% \text{ of } 10 = 9.2 \text{ bar}$$

$$P_2 = +8\% \text{ of } 10 = 10.8 \text{ bar}$$

and necessary volume will be:

$$V_o = \frac{\Delta V}{\frac{P_o}{P_1} - \frac{P_o}{P_2}} = \frac{18.2}{\frac{10}{10.2} - \frac{10}{11.8}} = 137 \text{ lt.}$$

Problem solution requires the use of an accumulator station with 3 accumulators type **AS55P360**...

3.4.2 Leakage compensator (isothermal)

- a) Assume a molding press working at 200 bar which has to be kept closed during the curing time and at constant pressure. Min. permissible pressure 198 bar. After the mold has been closed, the pump is stopped. The oil leakages are in the order of 2 cm³/minute. Curing time is 60 minutes.

$$\Delta V = Q_l \cdot t = 0.002 \times 60 = 0.12 \text{ lt.}$$

$$P_o = 0.9 \cdot 198 = 178 \text{ bar}$$

$$P_1 = 198 \text{ bar}$$

$$P_2 = 200 \text{ bar}$$

$$V_o = \frac{\Delta V}{\frac{P_o}{P_1} - \frac{P_o}{P_2}} = \frac{0.12}{\frac{179}{199} - \frac{179}{201}} = 13.41 \text{ lt.}$$

The capacity of the standard accumulator closest to the calculated value is **15 litres**. So the chosen accumulator is **AS15P360**...

- b) If it is required to know when the pump must operate again to reload an accumulator of 15 litres to maintain the condition stated on a), we will have:

$$t = \frac{\Delta V}{Q_l}$$

$$\Delta V = V_o \left[\frac{P_o}{P_1} - \frac{P_o}{P_2} \right]$$

$V_o = 14.5$ litres of nitrogen for accumulator AS15P360 (see page 18)

$$\Delta V = 14.5 \left[\frac{179}{199} - \frac{179}{201} \right] = 0.13 \text{ lt.}$$

where:

$$t = \frac{0.13}{0.002} = 65 \text{ min.}$$

3.5 Volume calculation (adiabatic condition)

Starting from the basic formula:

$$P_o \cdot V_o^n = P_1 \cdot V_1^n = P_2 \cdot V_2^n$$

and following what is shown for isothermal calculation, we have:

$$\Delta V = V_o \left[\left(\frac{P_o}{P_1} \right)^{\frac{1}{n}} - \left(\frac{P_o}{P_2} \right)^{\frac{1}{n}} \right] \quad \text{where } \frac{1}{n} = 0.7143$$

$$V_o = \frac{\Delta V}{\left(\frac{P_o}{P_1} \right)^{\frac{1}{n}} - \left(\frac{P_o}{P_2} \right)^{\frac{1}{n}}}$$

Formulas are valid when operation is taking place in adiabatic conditions both in the expansion as well as the compression phases.

Bear in mind however that accumulator yield, and therefore the accumulator calculation, is influenced by both operating temperature and pressure (see section 3.6 and 3.7).

This values of ΔV and V_o can be obtained from the diagrams on pages 14 and 15.

3.6 Temperature influence

It should be anticipated that the operating temperature will change considerably during the cycle and this variation should be taken into account when the volume is calculated.

If an accumulator is sized to a maximum temperature, then the precharge pressure will be referenced to that temperature. When the temperature drops there will be a comparable reduction of the precharge pressure according to the **Gay Lussac law** on the relationship between pressures and volumes, as a result, you will get a **lower accumulator capacity**.

Therefore it will be necessary to have a higher V_o to accumulate or to yield the same amount of liquid ΔV (see section 3.4).

The relationship between pressures and volumes is:

$$V_{oT} = V_o \frac{T_2}{T_1}$$

where:

$$T_2 = \theta_2 (^{\circ}\text{C}) + 273 = \text{max. working temperature } (^{\circ}\text{K}).$$

$$T_1 = \theta_1 (^{\circ}\text{C}) + 273 = \text{min. working temperature } (^{\circ}\text{K}).$$

V_o = volume calculated neglecting thermal variation (litres)

V_{oT} = increased volume for thermal variation (litres)

Example:

Assume the accumulator volume has to be calculated with the following data:

Stored volume $\Delta V = 1.7 \text{ Lt. in } 2 \text{ s}$

Min. pressure $P_1 = 50 \text{ bar}$

Max. pressure $P_2 = 115 \text{ bar}$

Operating temperature = $+25^{\circ}\text{C} \div +70^{\circ}\text{C}$

The precharge pressure referred to maximal temperature is:

$$P_o = 0.9 P_1 = 45 \text{ bar}$$

Volume, calculated in adiabatic conditions, will be:

$$V_o = \frac{\Delta V}{\left(\frac{P_o}{P_1}\right)^{\frac{1}{n}} - \left(\frac{P_o}{P_2}\right)^{\frac{1}{n}}} = \frac{1.7}{\left(\frac{46}{51}\right)^{0.7143} - \left(\frac{46}{116}\right)^{0.7143}} = 4.12 \text{ lt.}$$

Keeping in mind the temperature, we have:

$$V_{oT} = V_o \frac{T_2}{T_1} = 4.12 \frac{343}{298} = 4.74 \text{ lt.}$$

The precharge pressure at 20°C will be:

$$P_{o(20^{\circ}\text{C})} = 46 \times \frac{293}{343} = 39.3 \text{ abs. bar} = 38.3 \text{ relative bar}$$

The accumulator type is **AS5P360....**

3.7 Correction coefficient for high pressure

The formulas refer to ideal gases, but industrial nitrogen used in accumulators does not behave according to ideal gas laws when pressures increase.

It is convenient to keep in mind this characteristic for pressure $P_2 > 200 \text{ bar}$, both for adiabatic as well as for isothermal conditions.

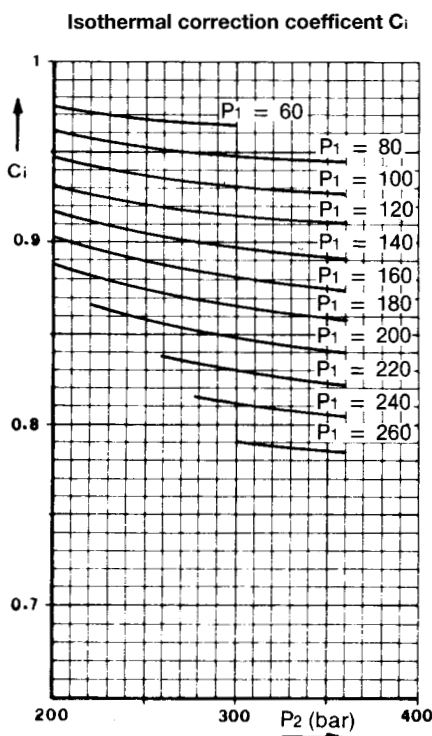

fig. 14

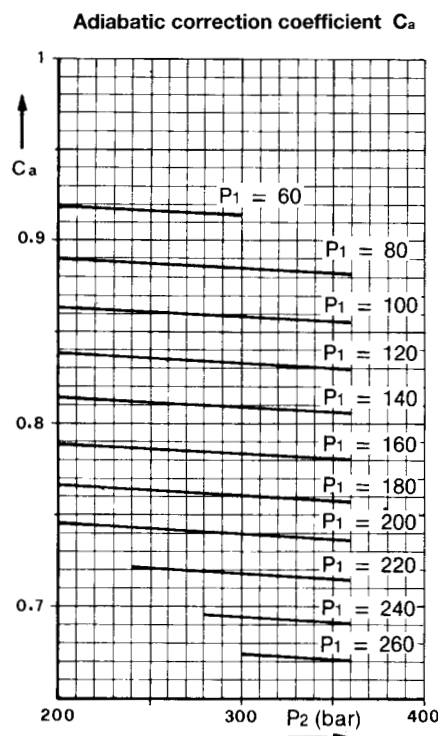

fig. 15

Value of V_o becomes:

$$V_{or} = \frac{V_o}{C_i} \text{ (isothermal)}$$

$$V_{or} = \frac{V_o}{C_a} \text{ (adiabatic)}$$

Yielded volume ΔV becomes:

$$\Delta V_r = \Delta V \cdot C_i \text{ (isothermal)}$$

$$\Delta V_r = \Delta V \cdot C_a \text{ (adiabatic)}$$

where:

V_{or} = real volume of accumulator to be used for operating pressures P_1 and P_2 .

ΔV_r = real yield obtained from accumulator for the same pressures.

C_i, C_a = Coefficients to be deduced from diagrams of Figures 14 and 15.

3.8 Emergency energy reserve

Typical occasion when storage is slow (isothermal) and discharge is quick (adiabatic).

Volume will be given by:

$$V_o = \frac{\Delta V}{\left(\frac{P_o}{P_2}\right)^{\frac{1}{n}} \cdot \left[\left(\frac{P_2}{P_1}\right)^{\frac{1}{n}} - 1\right]}$$

and stored volume by:

$$\Delta V = V_o \left(\frac{P_o}{P_2}\right)^{\frac{1}{n}} \cdot \left[\left(\frac{P_2}{P_1}\right)^{\frac{1}{n}} - 1\right]$$

where:

$n = 1.4$ adiabatic coefficient (quick discharge phase)

$n = 1 \div 1.4$ polytropic coefficient (slow storage phase)

Value is a function of time and it will be deduced from the diagram in Fig. 13.

In the majority of cases it is possible to suppose $n_c = 1$ so that calculation is simplified and result is not affected:

$$V_o = \frac{\Delta V \frac{P_2}{P_o}}{\left(\frac{P_2}{P_1}\right)^{0.7143} - 1}; \Delta V = V_o P_o \frac{\left(\frac{P_2}{P_o}\right)^{0.7143} - 1}{P_2}$$

Example:

An accumulator must discharge 4.6 litres of oil in 3 seconds with a change of pressure from $P_2 = 280$ bar to $P_1 = 220$ bar. The loading time is 4 minutes. Define the capacity keeping in mind that ambient temperature will change from 20°C to 50°C.

$$V_o = \frac{\Delta V}{\left(\frac{P_o}{P_2}\right)^{\frac{1}{1.1}} - \left[\left(\frac{P_2}{P_1}\right)^{\frac{1}{1.4}} - 1\right]}$$

$$= \frac{4.6}{\left(\frac{199}{281}\right)^{0.9091} \cdot \left[\left(\frac{281}{221}\right)^{0.7143} - 1\right]} = 33.63 \text{ lt.}$$

$P_1 = 221$ abs. bar $n_c = 1.1$ (from Figure 13)

$P_2 = 281$ abs. bar $T_1 = (273 + 20) = 293$ °K

$P_o = 0.9 \times 220 = 198 = 199$ bar abs. $T_2 = (273 + 50) = 323$ °K

Considering the correction coefficient for high pressure and the temperature change, we have:

$$V_{oT} = \frac{V_o}{C_m} \times \frac{T_2}{T_1} = \frac{33.63}{0.777} \times \frac{323}{293} = 47.7 \text{ lt.}$$

where:

$C_a = 0.72$

$C_i = 0.834$

$$C_m = \frac{C_a + C_i}{2} = 0.777$$

The precharge pressure at 20°C will be:

$$P_{o(20^\circ\text{C})} = 199 \times \frac{293}{323} = 180.5 \text{ bar} = 179.5 \text{ rel. bar}$$

The accumulator type is **AS55P360...**

3.9 Pulsation compensator Q

A typical calculation in adiabatic conditions due to high speed storage and discharge.

The liquid amount ΔV to be considered in the calculation is a function of type and capacity of pump:

$$\Delta V = K \cdot q$$

Volume becomes:

$$V_o = \frac{K \cdot q}{\left(\frac{P_o}{P_1}\right)^{0.7143} - \left(\frac{P_o}{P_2}\right)^{0.7143}}$$

where:

q = pump displacement (litres)

= $A \times C$ (piston surface x stroke)

$$= \frac{Q}{n} = \frac{\text{flow rate (l/min)}}{\text{strokes/min.}}$$

P = average working pressure (bar)

$P_1 = P - X$ (bar)

$P_2 = P + X$ (bar)

$$X = \frac{\alpha \cdot P}{100} \text{ (bar deviation from average pressure)}$$

α = remaining pulsation \pm (%)

K = coefficient taking into account the number of piston and if pump is single or double acting.

Pump type	K
1 piston, single acting	0.69
1 piston, double acting	0.29
2 pistons, single acting	0.29
2 pistons, double acting	0.17
3 pistons, single acting	0.12
3 pistons, double acting	0.07
4 pistons, single acting	0.13
4 pistons, double acting	0.07
5 pistons, single acting	0.07
5 pistons, double acting	0.023
6 pistons, double acting	0.07
7 pistons, double acting	0.023

Example:

Assume a 3-piston pump, single acting, with a flow rate $Q = 8$ m³/h and operating pressure of 20 bar. Calculate the volume necessary to limit the remaining pulsation to $\alpha = \pm 2.5\%$. Pump R.P.M. 148. Working temperature 40°C.

$$P = 20 \text{ bar} \quad q = \frac{8000}{60 \times 148 \times 3} = 0.3 \text{ lt.}$$

$P_2 = (20 - 0.5) = 19.5$ bar

$P_1 = (20 + 0.5) = 20.5$ bar

$K = 0.12$

$P_o = (0.7 \cdot 20) = 14$ bar

$$X = \frac{2.5 \times 20}{100} = 0.5 \text{ bar}$$

$$V_o = \frac{0.12 \times 0.3}{\left(\frac{15}{20.5}\right)^{0.7143} - \left(\frac{15}{19.5}\right)^{0.7143}} = 1.345 \text{ lt.}$$

$$P_{o(20^\circ\text{C})} = 15 \times \frac{293}{313} = 14 \text{ abs. bar} = 13 \text{ bar rel.}$$

The most suitable accumulators is the low pressure type: **AS1,5P80...**

3.10 Hydraulic line shock damper

A rapid increase in pressure caused by a high acceleration or deceleration in flow is commonly known as water hammer. The overpressure, ΔP_{max} , that takes place in piping when a valve is closed is influenced by the length of the piping, the flow rate, the density of the liquid and the valve shut down time. This is given by:

$$\Delta P_{max} \text{ (bar)} = \frac{2 \gamma L v}{t \times 10^5}$$

The volume of the accumulator required to reduce shock pressure within predetermined limits ΔP , is obtained with:

$$V_o = \frac{Q \left(\frac{2 \gamma L v}{\Delta P_o \times 10^5} - t \right)}{\left(\frac{P_o}{P_1} \right)^{0.7143} - \left(\frac{P_o}{P_2} \right)^{0.7143}}$$

where:

V_o = accumulator gas capacity (litres)

Q = flow rate in the piping (m^3/h)

L = total length of piping (m)

γ = specific gravity of liquid (kg/m^3)

$V = \frac{Q}{S} \times \frac{10^3}{3.6}$ = flow velocity (m/s)

$S = \frac{\pi d^2}{4}$ = internal pipe section (mm^2)

d = internal pipe diameter (mm)

ΔP = allowable overpressure (bar)

P_1 = operating pressure by free flow (absolute bar)

$P_2 = P + \Delta P$ = max allowable pressure (absolute bar)

t = deceleration time (s) (valve shut down, etc.)

Example:

Assume a water pipe ($\gamma = 1000 \text{ Kg/m}^3$) with internal diameter $d = 80 \text{ mm}$, length $L = 450 \text{ m}$, flow rate $Q = 17 \text{ m}^3/h$, operating pressure $P_1 = 5 \text{ bar}$, allowable overpressure $\Delta P = 2 \text{ bar}$, valve closure time $t = 0.8 \text{ s}$.

$$\Delta P_{max} = \frac{2 \times 1000 \times 450 \times 0.94}{0.8 \cdot 10^5} = 10.57 \text{ bar}$$

The accumulator volume necessary to reduce the ΔP_{max} to 2 bar is:

$$V_o = \frac{17 \left(\frac{2 \times 1000 \times 450 \times 0.94}{2 \times 10^5} - 0.8 \right)}{\left(\frac{5.5}{6} \right)^{0.7143} - \left(\frac{5.5}{8} \right)^{0.7143}} = 46.4 \text{ lt.}$$

where: $S = \frac{\pi \times 80^2}{4} = 5026.5 \text{ mm}^2$

$$V = \frac{17 \times 10^3}{5026.5 \times 3.6} = 0.94 \text{ m/s}$$

$$P_o = 5 \times 0.9 = 4.5 = 5.5 \text{ abs. bar}$$

$$P_1 = 6 \text{ abs. bar}$$

$$P_2 = 5 + 2 = 7 \text{ bar} = 8 \text{ abs. bar}$$

An accumulator of 55 litres low pressure range will be chosen, type **AS55P30....**

3.11 Accumulator + additional gas bottles (transfer)

In all cases where a considerable amount of liquid must be obtained with a small difference between P_1 and P_2 , the resultant volume V_o is large compared to ΔV .

In these cases it could be convenient to get the required nitrogen volume by additional bottles.

Volume calculation is performed, in function of the application, both in isothermal as well as in adiabatic conditions using the formulas given before always taking temperature into account.

To get the maximum of efficiency it is convenient to fix for precharge quite a high value. In cases of **energy reserve, volume compensator, hydraulic line shock damper**, etc. it is possible to use:

$$P_o = 0.97 P_1$$

Once the required gas volume is calculated, the volume must be allocated between the minimum indispensable portion V_A , which will be contained in the accumulator, and the remaining portion V_B , which represents the volume of additional bottles.

$$V_{oT} = V_{oA} + V_{oB}$$

where:

$$V_{oA} \geq \frac{\Delta V + (V_{oT} - V_o)}{0.75}$$

That means that the sum of volume of required liquid plus volume change due to temperature must be **lower than 3/4 of accumulator capacity**.

The bottle volume is given by the difference

$$V_{oB} = V_{oT} - V_{oA}$$

Example:

Suppose a $\Delta V = 30 \text{ lts.}$ must be obtained in 2 seconds going from a pressure $P_2 = 180 \text{ bar}$ to $P_1 = 160 \text{ bar}$.
Temperatures: $\theta_1 = 20^\circ\text{C}$; $\theta_2 = 45^\circ\text{C}$

$$P_{o(50^\circ\text{C})} = 0.97 \times 160 = 155 \text{ bar}$$

$$V_o = \frac{\Delta V}{\left(\frac{P_o}{P_1} \right)^{0.7143} - \left(\frac{P_2}{P_1} \right)^{0.7143}} = \frac{30}{\left(\frac{156}{161} \right)^{0.7143} - \left(\frac{156}{181} \right)^{0.7143}} = 382.4 \text{ lt.}$$

$$V_{oT} = 382.4 \times \frac{318}{293} = 415 \text{ lt.}$$

$$V_{oA} = \frac{30 + (415 - 382.4)}{0.75} = 83.5 \text{ lt.}$$

Two accumulators AS55P360.... are used with total $V_o = 100 \text{ lts.}$ plus **6 bottles of 50 lts.** type **BB52P360...**

3.12.1 Selection of volumes (isothermal conditions) - low pressure graph

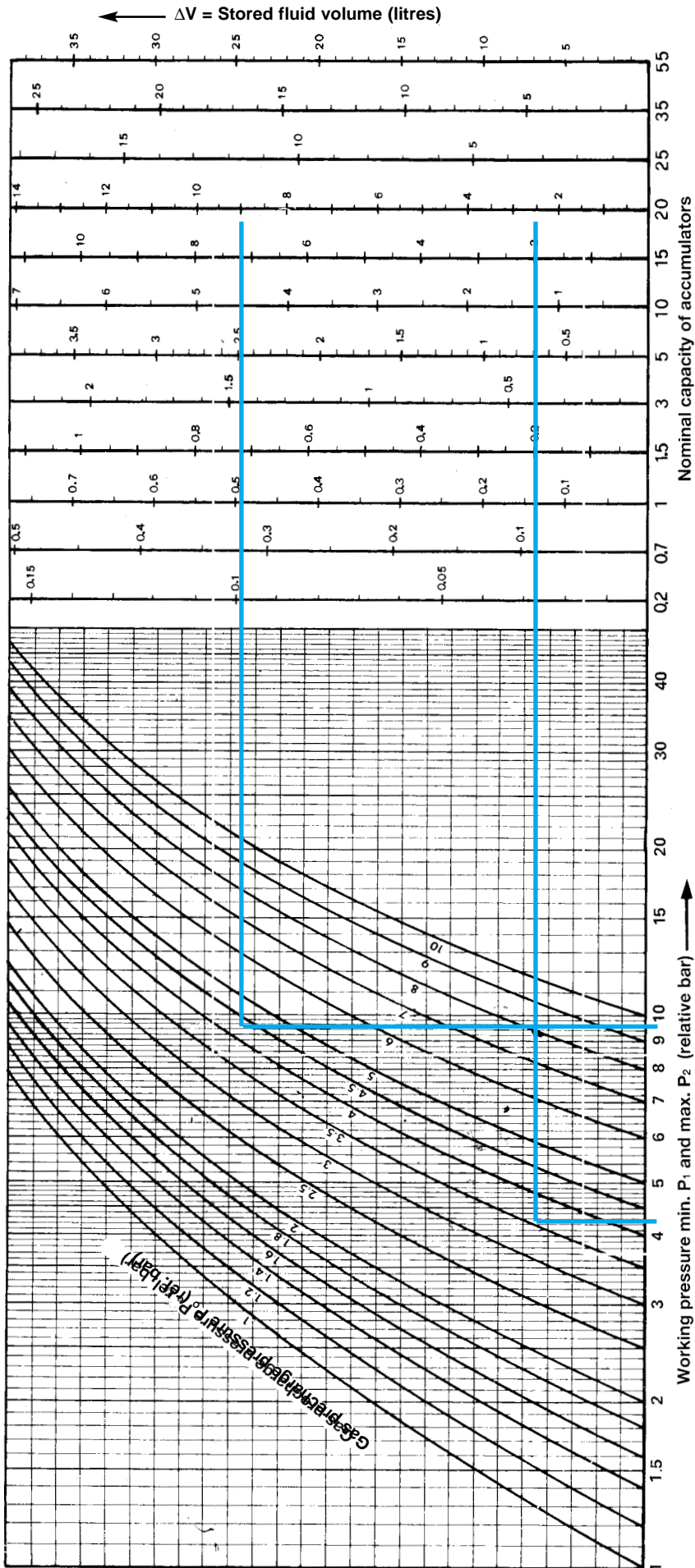

Example I: Evaluation of accumulator volume

Data:
 Max. working pressure $P_2 = 8.5$ bar
 Min. working pressure $P_1 = 3.8$ bar
 Precharge pressure $P_0 = 3.5$ bar
 Required liquid volume $\Delta V = 1.3$ litres

Starting from the 2 intersection points of curve of $P_0 = 3.5$ with the ordinates of $P_1 = 3.8$ and $P_2 = 8.5$ trace 2 straight lines parallel to the abscissa axis reaching the scales of ΔV .

Stored volume, for each capacity, is the one included between the two traced straight lines. In our case the accumulator giving the storage closest to the required one, that is 1.3 lts., has the capacity of **3 litres**.

Example II: Evaluation of stored liquid ΔV

Data:
 Max. working pressure $P_2 = 8.5$ bar
 Min. working pressure $P_1 = 3.8$ bar
 Precharge pressure $P_0 = 3.5$ bar
 Accumulator capacity $V = 15$ litres

Starting from the 2 intersection points of curve of $P_0 = 3.5$ with the ordinates of $P_1 = 3.8$ and $P_2 = 8.5$ trace 2 straight lines parallel to the abscissa axis reaching the scale of ΔV corresponding to 15 litres.

Yielded volume, included between the two straight lines, is approximately **6.7 litres**.

3.12.2 Selection of volumes (isothermal conditions) - high pressure graph

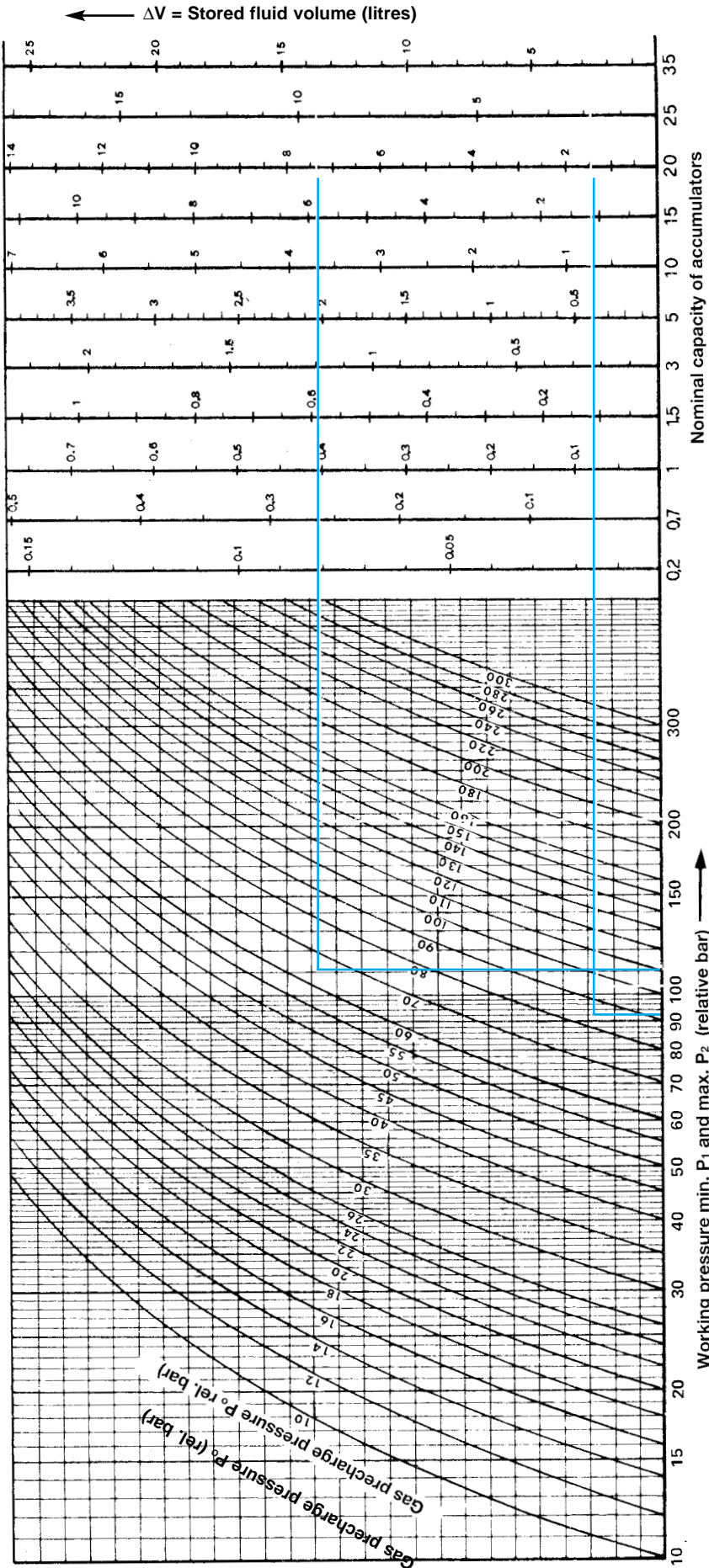

Example I:
Evaluation of accumulator volume

Data:
 Max. working pressure $P_2 = 190$ bar
 Min. working pressure $P_1 = 100$ bar
 Precharge pressure $P_0 = 90$ bar
 Required liquid volume $\Delta V = 7$ litres

Starting from the 2 intersection points of curve of $P_0 = 90$ with the ordinates of $P_1 = 100$ and $P_2 = 190$ trace 2 straight lines parallel to the abscissa axis reaching the scales of ΔV . Stored volume, for each capacity, is the one included between the two traced straight lines. In our case the accumulator giving the storage closest to the required one, that is ≥ 7 lts., has the capacity of **20 litres**.

Example II:
Evaluation of stored liquid ΔV

Data:
 Max. working pressure $P_2 = 190$ bar
 Min. working pressure $P_1 = 100$ bar
 Precharge pressure $P_0 = 90$ bar
 Accumulator capacity $V = 1.5$ litres

Starting from the 2 intersection points of curve of $P_0 = 90$ with the ordinates of $P_1 = 100$ and $P_2 = 190$ trace 2 straight lines parallel to the abscissa axis reaching the scale of ΔV corresponding to 1.5 litres.
 Yielded volume, included between the two straight lines, is approximately **0.615 litres**.

3.13.1 Selection of volumes (adiabatic conditions) - low pressure graph

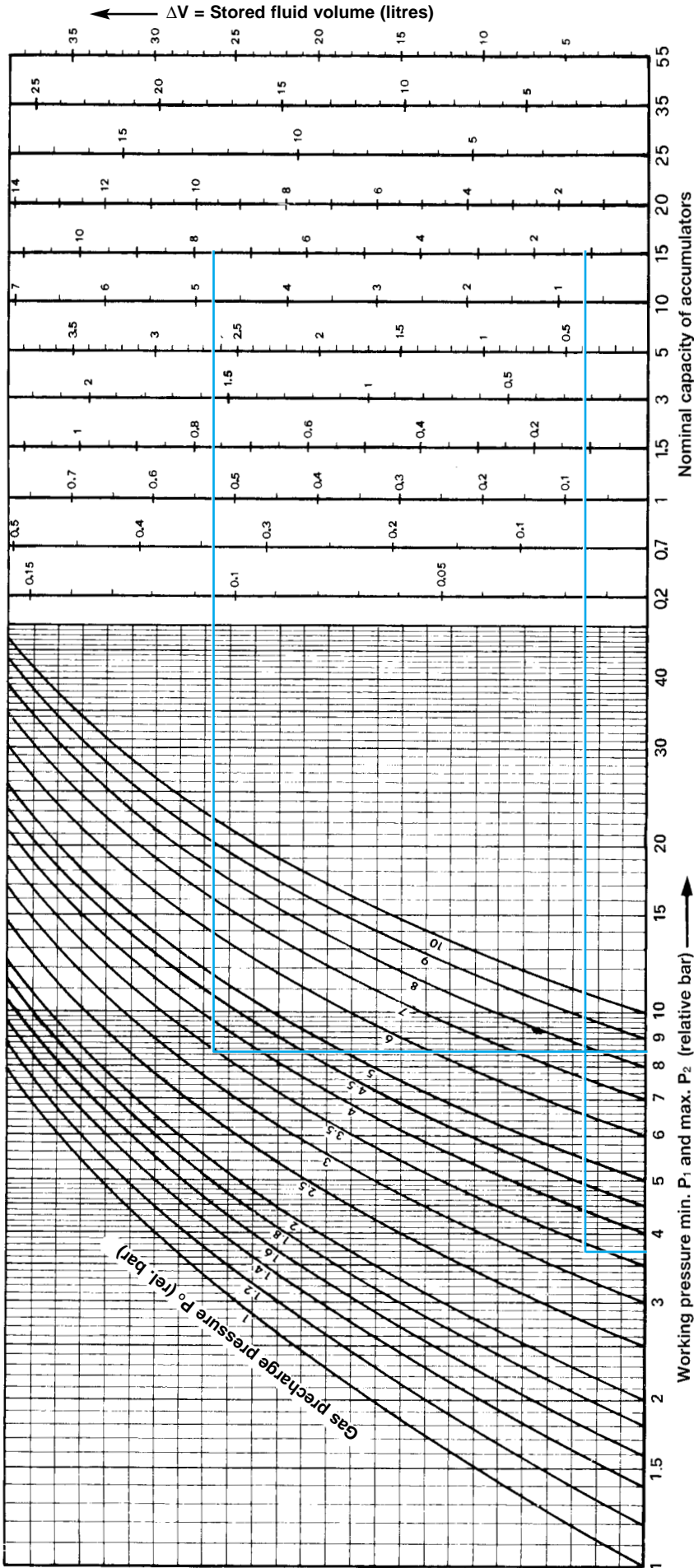

Example I:
Evaluation of accumulator volume

Data:
 Max. working pressure $P_2 = 8.5$ bar
 Min. working pressure $P_1 = 3.8$ bar
 Precharge pressure $P_0 = 3.5$ bar
 Accumulator capacity $\Delta V = 1.3$ litres

Starting from the 2 intersection points of curve of $P_0 = 3.5$ litres with the ordinates of $P_1 = 3.8$ and $P_2 = 8.5$ trace 2 straight lines parallel to the abscissa axis reaching the scales of ΔV .
 Stored volume, for each capacity, is the one included between the two traced straight lines. In our case the accumulator giving the storage closest to the required one, that is 1.3 lts., has the capacity of **5 litres**.

Example II:
Evaluation of stored liquid ΔV

Data:
 Max. working pressure $P_2 = 8.5$ bar
 Min. working pressure $P_1 = 3.8$ bar
 Precharge pressure $P_0 = 3.5$ bar
 Accumulator capacity $V = 15$ litres

Starting from the 2 intersection points of curve of $P_0 = 3.5$ with the ordinates of $P_1 = 3.8$ and $P_2 = 8.5$ trace 2 straight lines parallel to the abscissa axis reaching the scale of ΔV corresponding to 15 litres.

Yielded volume, included between the two straight lines, is approximately **5.3 litres**.

3.13.2 Selection of volumes (adiabatic conditions) - high pressure graph

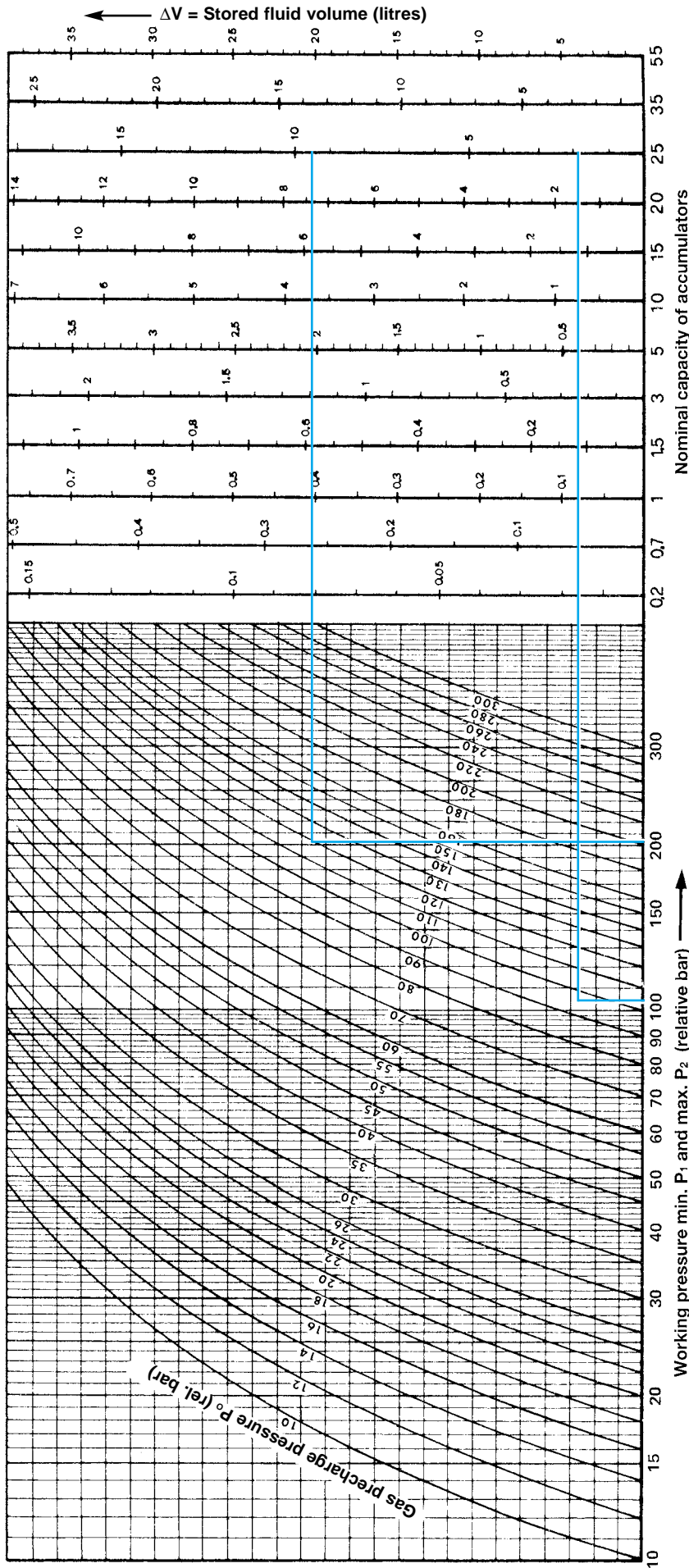

Example I:
Evaluation of accumulator volume

Data:
 Max. working pressure $P_2 = 190$ bar
 Min. working pressure $P_1 = 100$ bar
 Precharge pressure $P_0 = 90$ bar
 Accumulator capacity $\Delta V = 7$ litres

Starting from the 2 intersection points of curve of $P_0 = 90$ with the ordinates of $P_1 = 100$ and $P_2 = 190$ trace 2 straight lines parallel to the abscissa axis reaching the scales of ΔV . Stored volume, for each capacity, is the one included between the two traced straight lines. In our case the accumulator giving the storage closest to the required one, that is ≥ 7 lts., has the capacity of **25 litres**.

Example II:
Evaluation of stored liquid ΔV

Data:
 Max. working pressure $P_2 = 190$ bar
 Min. working pressure $P_1 = 100$ bar
 Precharge pressure $P_0 = 90$ bar
 Accumulator capacity $V = 1.5$ litres

Starting from the 2 intersection points of curve of $P_0 = 90$ with the ordinates of $P_1 = 100$ and $P_2 = 190$ trace 2 straight lines parallel to the abscissa axis reaching the scale of ΔV corresponding to 1.5 litres.

Yielded volume, included between the two straight lines, is approximately **0.49 litres**.

3.14 Flow rate

After the size of accumulator has been defined, as previously stated, it is necessary to check whether the required flow rate (l/min) is compatible with the permissible flow rate for that accumulator, according to the following table.

Maximum flow rate can be achieved with the accumulator installed in vertical position with the gas valve on top. Furthermore it is indispensable that a residual volume of liquid $\geq 0,1 \times V_0$ remains in the accumulator.

Type	Mean flow rate (l/min)	Max perm. flow rate (l/min)
AS 0.2	70	160
AS 0.7-1-1.5	150	300
AS 3-5	300	600
AS 10-55	500	1000

3.15 Bladder material

The choice of elastomer used for the bladder depends on the liquid to be used and on the operating temperatures (and, at times, storage). In the chart below, each polymer has a designated letter which, in the order code, denotes the material used for the bladder, the gaskets and rubber-coated parts. For special liquids, we recommend you to contact our technical information service.

Code letter	Polymer	ISO	Temperature range (°C)	Some of the liquids compatible with the polymer
P	Standard nitrile (Perbunan)	NBR	-20 +85	Mineral, vegetable, silicon and lubricating oils, industrial waters, glycols, nonflammable liquids (HFA - HFB - HFC), aliphatic hydrocarbons, butane, diesel oil, kerosene, fuel oils, etc.
F	Low temperature nitrile	NBR	-40 +70	The same as with standard nitrile + a number of different types of Freon. (This contains less acrylonitrile than the standard and is therefore more suitable for low temperatures, but its chemical resistance is slightly lower).
H	Nitril for hydrocarbons	NBR	-10 +90	Regular and premium grade slightly aromatic gasoline (and all the liquids for standard nitrile).
K	Hydrogenated nitrile	HNBR	-30 +130	The same as with standard nitrile but with excellent performance at both high and low temperatures.
A	For food stuff	NBR	-20 +85	Foods (specify which type when order).
B	Butyl	IIR	-30 +90	Phosphoric esters (HFD-R), hot water, ammonia, caustic soda, some kinds of freon (22-31-502), glycol-based brake fluids, some acids, alcohols, ketones, esters, skydrol 7000, etc.
E	Ethylene-Propylene	EPDM	-20 +90	Brake fluids, hot water, leaching fluids, detergents, water-glycol (HFC), many acids and bases, saline solutions, skydrol 500, etc.
N	Chloroprene (Neoprene)	CR	-20 +85	Freon (12-21-22-113-114-115), water and aqueous solutions, ammonia, carbon dioxide, mineral, paraffin and silicon oils.
Y	Epichloridrin	ECO	-30 +110	Lead-free gasoline, mineral oils.

3.16 Durability of the bladder

It is essential, in order to make the correct choice, to take into consideration the working conditions that the accumulator will be operating in, because these can considerably affect the durability of the bladder. Assuming that the liquid used is **clean** and compatible with the bladder material, there are a number of factors which can affect the life of the bladder:

- **The precharge pressure P_0 .** In most cases the values recommended in section 3.2 are valid although, as the pressure and, above all, the velocity of the yield required increase, there is the danger that in each cycle the bladder will knock against the poppet valve. In these case is possible to use $P_0 = 0,8 \div 0,7 P_1$.
- **The P_2/P_0 ratio.** Any increase in this, will increase the stress the bladder is subjected to in each cycle. Only for special applications it is possible to exceed the ratio $P_2/P_0 = 4$ (in this case consult our Technical Service Department).
- **The maximum operating pressure P_2 .** Any increase in this will subject the bladder to greater stress.
- **Flow rate.** Flow rate does not affect bladder working life if values given in table 3.14 are not exceeded. When approaching the maximum values, make sure that remains a residual volume of liquid $\geq 10\%$ of volume V_0 in the accumulator, in both loading and unloading phases.
- **The frequency** or the number of cycles per day.
- **Installation.** The vertical position with gas valve on top is the recommended arrangement. When position is horizontal the bladder tends to rest and rub against the accumulator body. This could result in quicker wear.
- **The operating temperature.** This is one of the factors which most affects the life of the bladder: at very low temperatures the bladder tends to become brittle; as the temperature rises, reaching, or going beyond the limits for the elastomer, the stress of the bladder is subjected to increases exponentially, which can lead to fracturing within a short time. It should be remembered that the temperature in the accumulator is in many cases higher than the one of the system, and that it rises with each increase of P_2 , of P_2/P_1 , and with the volume of the accumulator (in other words, larger is the accumulator, less is the capacity of dissipate heat).

All the EPE bladder models, in the standard nitrile rubber P version, have undergone the following fatigue test: $P_0 = 65$ bar; $P_1 = 90$ bar; $P_2 = 200$ bar; frequency 10 cycles/min; oil temperature 45 °C; duration > 10⁶ cycles.

3.17 Material of accumulator shell and valves

In standard version, the shell is made of carbon steel and painted on the outside with a coat of rust inhibitor; the valves are made of phosphated carbon steel.

This configuration is suitable for **fluids of group 2** and the whole assembly is indicated in the identification code by the letter **C**.

For special applications, shell and valves, usually in carbon steel, can be nickel coated.

3.18 Testing

Accumulators are pressure vessels subjected to the specific current regulations, or accepted, of the Countries that will be installed.

For all the **European Countries**, design, construction and accumulator test must be done according to the Directive of pressure equipment 97/23/EC. EPE ITALIANA, also in virtue of quality system used EN ISO 9001:2000, works according to **modules H and H1** of total quality guarantee and design control issued by the Notify Body. The above mentioned directive includes the pressure equipment that exceed 0,5 bar. So all the accumulators are involved in this directive even though it provides different procedures of test and certification.

Concerning this, keep in mind that accumulators **up to 1 litre volume included**, even if it is manufactured according to the Directive 97/23/EC, are not marked EC and are not provided with the conformity declaration.

For volumes **higher than 1 litre** each accumulator after the test is marked with the mark **CE** followed by the number that identify the Notify Body.

For these accumulators, both high pressure and low pressure, the documentation necessary includes the conformity declaration and the manual's operator.

It is also possible supply accumulators in accordance with Directive **ATEX 94/9/EC** (enclosure VIII) and with harmonized regulations EN 13463-1 related to equipment not electrical for uses in environment with atmosphere potentially explosive that are included into the classification ATEX EC II2GcT4.

Minimal thickness 25 micron. Identification code letter **N** (specify different thickness separately).

In some cases the execution is completely in stainless steel (indicated by letter **X**).

If specifically requested, the fluid port and/or the gas valve can be supplied in a different material to the one used for the accumulator shell. **Only in this case**, it is necessary to add to the identification code the letter indicating each valve. (see section 3.19).

EPE ITALIANA provide also other tests and certifications for those Countries in which EC regulations are not accepted:

- ASME-U.S. for USA, Canada, South Africa, etc..
- ML (ex SQL) for China.
- Australian Pressure Vessel Standard AS1210-1997 for Australia.
- GOST for Russia.
- RINA and in some cases BS-L Lloyd's Register and Germanischer Lloyd for naval construction.
- For other Countries, in which is not required a specific test, accumulators are in any case manufactured according to the European Directive but are supplied without EC mark and with factory test only.

The documentation related to each regulation is normally provided in a proper envelope along with the goods. If it's not available, will be sent by post or in another way as soon as possible.

In order to define correctly both the price and the availability, **it is necessary that in the inquiry is mentioned the required certification.**

3.19 Model Code

Please note that when compiling the model code **the capacity, operating pressure, the shell material**, etc. should be selected from **those available in each range** of accumulator only (see pages 18 ÷ 22). The precharge pressure should be specified separately, as the flange or fluid port adapter or the adapter on the gas side.

Accumulator type	Nominal capacities ¹⁾	Bladder material	Max working pressure	Shell and valves material	Fluid port connection	Tests and certifications	Fluid port material ²⁾	Gas Valve material ²⁾
AS = Bladder accumulator (standard)	Litres 0,2 - 0,7	P = Standard nitrile (Perbunan)	³⁾ Bar 360 - 550 (High pressure carbon steel)	C = Shell painted carbon steel	G = Female ISO 228	0 = Factory testing	- = The same to material shell	- = The same to material shell
AST = Transfer bladder accumulator	1 - 1,5	F = Nitrile for low temperatures	360 ÷ 100 (High pressure stainless steel)	Valves: Phoshated carbon steel	L = For flange SAE 3000	1 = GOST (RUSSIA)	C = Phoshated carbon steel	C = Phoshated carbon steel
ASL = Liquid separator bladder accumulator	3 - 5	H = Nitrile for Hydrocarbons	80 - 30 (Low pressure carbon steel)	N = Nickel coated carbon steel (thickness 25 µm)	H = For flange SAE 6000	2 = AUSTRALIAN PRESSURE VESSEL STANDARD (AUSTRALIA)	C = Phoshated carbon steel	N = Nickel coated carbon steel 25 µm
	10 - 15	K = Hydrogenated Nitrile	40 - 25 (Low pressure stainless steel)	X = Stainless steel	M = Metric thread	3 = ML (ex SQL) (CHINA)	N = Nickel coated 25 µm	N = Nickel coated carbon steel 25 µm
	20 - 25	A = For food-stuffs		V = Carbon steel with special coating (to be specified)	P = NPT thread	4 = RINA	X = Stainless Steel	X = Stainless Steel
	35 - 55	B = Butyl			S = SAE thread ⁵⁾	5 = BS-LLOYD'S REGISTER		
ASA = Bladder accumulator ASME-U.S.	Gallons 1/4 - 1	E = Ethylene-propylene			R = With adapter ⁵⁾	6 = GERMANISCHER LLOYD		
ASAT = Transfer for ASME-U.S.	2,5 - 5	N = Chloroprene (Neoprene)			F = With flange ⁵⁾	7 = ASME-U.S. (USA)		
ASAL = Liquid separator for ASME-U.S.	10 - 15	Y = Epichlorohydrin	⁴⁾ Psi 4000			8 = 97/23/EC (EUROPE)		
						9 = ATEX (94/9/EC)		
						10 = Other to be specified		

1) Capacity in gallons only for the series ASA.

2) Specify both when **at least one** is made of different material from the accumulator shell

3) Use the proper value among those indicated on pages 18÷21 related to the chosen version

4) Pressure in Psi only for the series ASA.

5) To be specified separately

4.1 Technical features

Max working pressure PS:	360 bar
Test pressure PT:	PS x 1,43 bar
Temperature range min. and max TS:	-40°C ÷ +120°C (subject to restrictions due to bladder material)
Nominal capacities:	0,2 ÷ 55 litres

4.2 Construction features

THE STANDARD VERSION (AS) INCLUDES:

- Shell in hardened and tempered carbon steel, sandblasted and painted outside with a coat of rust inhibitor.
- Valves in phosphated carbon steel.
- Female ISO 228 G threaded fluid port connection.
- Bladder and gaskets in standard nitrile rubber (P).
- Testing and certification according to directive 97/23/EC.
- Preloading with nitrogen at **30 bar** (other values available if specified in order).

N.B. Technical features of **AS** standard version are also valid for **AST** and **ASL** versions except for the structure of gas side valve (see pages 36 and 37).

ON REQUEST the accumulator can be supplied with the following features:

- SHELL AND VALVES PROTECTED with a chemical coating of nickel (25 microns thick. Specify other thickness if required).
- SHELL AND VALVES IN STAINLESS STEEL
0.2 lts. capacity: max working pressure **210 bar** and **360 bar**.
0.7-1-1.5-3 lts. capacities: max working pressure **150 bar**.
5 lts. capacity: max working pressure **120 bar**.
10-55 lts. capacities: max working pressure **100 bar**.
 For other pressure values contact our Technical Department.
- BLADDER IN BUTYL, NEOPRENE, ETHYLENE-PROPYLENE, HYDROGENATED NITRILE, NITRILE FOR LOW TEMPERATURES (-40°C), NITRILE FOR HYDROCARBONS, EPICHLOROHYDRIN FOR FOODSTUFFS.
- WORKING PRESSURE PS = 550 BAR for capacities 0,2 and 0,7 litres in carbon steel.
- SAE 3000 or SAE 6000 FLUID PORT CONNECTION (see page 24).
- NPT, SAE or METRIC THREADED FLUID PORT CONNECTION.
- ADAPTER R with ISO 228 thread for the diameters indicated in the table, with other threads to be specified or blind.
- FLUID PORT FLANGED CONNECTION (specify PN and DN and flange standards. For order code see page 24)¹⁾.
- GAS SIDE FLANGED CONNECTION for special applications¹⁾.
- SAFETY VALVE gas side or liquid side or only with the adapter for this valve (see pages 26-27)¹⁾.
- SPECIAL ANTI-PULSATION CONNECTION liquid side (see page 25)¹⁾.
- TESTINGS AND CERTIFICATIONS DIFFERENT FROM EC (Ask for availability).

1) Specify features separately.

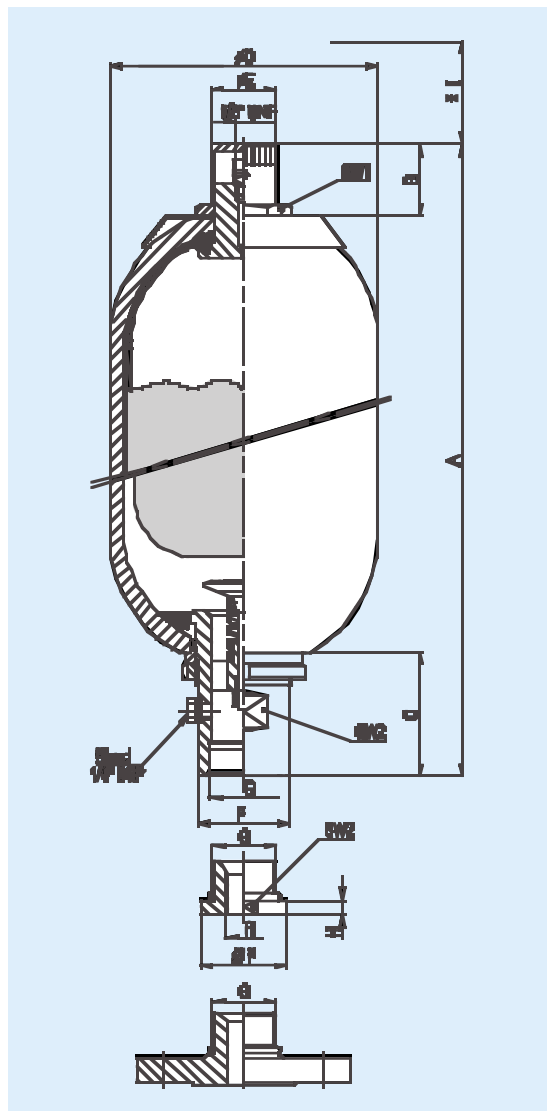

4.3 Dimensions 2)

Type	Max work. pressure (bar)	Gas volume (Litres)	Dry weight (kg)	Fluid port connection		A	B	C	øD	øE	øF	H	I*	SW 1	SW 2
				G BSP ISO228	R BSP ISO228										
AS 0,2	360-550	0,2	1,7	1/2"	—	250 ± 2	22	40	53 + ₀ ¹	20	26	—		24	23
AS 0,7	360-550	0,65	4,2	3/4"	0=blind 3/8" 1/2"	280 ± 3	47	52	90 ± 1	25	36	11	140	32	32
AS 1	360	1	5,2			295 ± 5									
AS 1,5	360	1,5	6,3			355 ± 5									
AS 3	360	2,95	11	1 1/4"	0=blind 3/8" - 1/2" - 3/4"	553 ± 8	65	65	114 ± 1	25	53	11	140	32	50
AS 5	360	5	15			458 ± 10									
AS 10	360	9,1	33	2"	0=blind 3/8" 1/2" 3/4" 1" 1 1/4" 1 1/2"	568 ± 15	60	101	224 ± 2	55	77	11	140	70	70
AS 15	360	14,5	43			718 ± 15									
AS 20	360	18,2	48			873 ± 15									
AS 25	360	23,5	59			1043 ± 15									
AS 35	360	33,5	78			1392 ± 20									
AS 55	360	50	108			1910 ± 20									

* 1 = Overall dimensions of pre-loading unit.

2) = Data related to standard version in carbon steel PS = 360 bar.

Subject to change

4.4 Components and spare parts

Table 4.4.1 provides a list of accumulator components and, for each model, the part number to be used when ordering spare parts: **THIS NUMBER IS VALID FOR STANDARD VERSIONS ONLY.**

For all versions differing from standard it is necessary to give the **manufacturer's serial number and the material.**

The bladder must be ordered according to the instructions provided on Page 37 or giving the accumulator identification code or manufacturer's serial number.

Capacity 0.2 litres

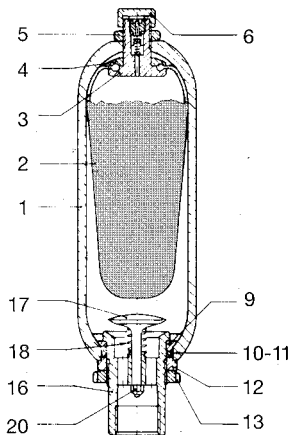

Capacities 0.7÷55 litres

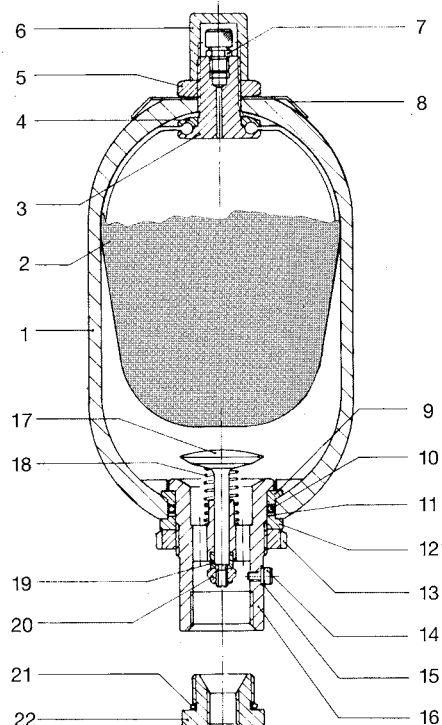

4.4.1 Spare parts list and part number

Item	Description	Pcs.	Models					AS 10-15-20 25-35-55
			AS 0,2	AS 0,7	AS 1 - 1,5	AS 3	AS 5	
1	Accumulator shell	1	Not supplied as spare part					
2	Bladder	1	See detailed designation on Pages 36-37					
3	Gas valve body	1	2001	10107		10202	10333	
4	Rubber-coated washer	1	10024	10104	10106	10205	10334	
5	Gas valve locknut	1	10023	10109			10302	
6	Protection cap	1	10337	10103			10301	
7	Gas-fill valve	1	–	2072				
8	Name plate	1	–	10300-A	10300-B		10300-C	10300-D
9	Retaining ring	1	10035	10123	10127	10146	10222	10317
10	“O” ring	1	OR4112	OR4150		OR159	OR6212	OR181
11	Supporting ring	1	10038	10133		10150	10227	10320
12	Space ring	1	10037	10120		10145	10223	10319
13	Fluid port ring nut	1	10039	10122		10217		10321
14	Bleed screw	1	–	10128				10316-A
15	Seal ring	1	–	10129				10336-A
16	Fluid port body	1	10031	10115		10144		10311
17	Poppet	1	10028	10111		10221		10310
18	Spring	1	10029	10112		10149		10322
19	Brake bushing	1	–	10113		10226		10314
20	Selflocking nut	1	10033	10116		10211		10315
21	Adapter “O” ring	1	–	OR2093		OR3150		OR3218
22	Adapter	1	–	10131/Ø thread		10233/Ø thread		10323/Ø thread
Gas valve assembly (parts 3-4-5-6-7)		1	2002	2021	2022		2042	2062
Fluid port assembly (parts 9 ÷20)		1	2004	2023	2024	2025	2044	2064
Gasket sets		1	2010 { OR2050 10341 10342 OR4112 10038	2030 { OR2050 10341 10342 OR4150 10133 10129 OR2093	2031 { OR2050 10341 10342 OR159 10149 10129 OR3150	2050 { OR2050 10341 10342 OR6212 10227 10129 OR3150	2080 { OR2050 10341 10342 OR181 10320 10336 OR3218	

5.1 Technical features

Max working pressure PS:	30-80 bar
Test pressure PT:	PS x 1,43 bar
Temperature range min. and max TS:	-40°C ÷ 150°C (subject to restrictions due to bladder material)
Nominal capacities:	1.5-3-5-10-15-20-25-35-55 Litres
Precharge pressure:	≤ 15 bar

5.2 Construction features
THE STANDARD VERSION (AS) INCLUDES:

- Shell in welded carbon steel, sandblasted and painted outside with a coat of rust inhibitor.
- Gas valve in phosphated carbon steel.
- Female (G) ISO 228 threaded fluid port connection.
- Bladder in standard oil resistant nitrile rubber (P).
- Testing and certification according to directive 97/23/EC.
- Preloading with nitrogen at **5 bar** (other values available if specified in order).

N.B. Technical features of **AS** standard version are also valid for **AST** and **ASL** versions except for the structure of gas side valve (see pages 36 and 37).

ON REQUEST the accumulator can be supplied with the following features:

- **SHELL AND VALVES PROTECTED** with a chemical coating of nickel (25 microns thick. Specify other thickness if required).
- **SHELL AND VALVES IN STAINLESS STEEL**
1.5-3 and 5 lts. capacities: max working pressure **40 bar**.
10 - 55 lts. capacities: max working pressure **25 bar**.
 For all sizes the certificate for the material and works test can be supplied.
- **BLADDER IN BUTYL, NEOPRENE, ETHYLENE-PROPYLENE, HYDROGENATED NITRILE, NITRILE FOR LOW TEMPERATURE (-40°C), NITRILE FOR HYDROCARBONS, EPICHLOROHYDRIN FOR FOODSTUFF.**
- **WORKING PRESSURE 50 bar** for capacities 10 ÷ 55 litres in carbon steel.
- **ADAPTER R** with ISO 228 thread for the diameters indicated in the table, with other threads to be specified or blind.
- **FLUID PORT FLANGED CONNECTION** (specify PN and DN and flange standards. For order code see page 24)¹⁾.
- **GAS SIDE FLANGED CONNECTION** for special applications (specify flange data)¹⁾.
- **SAFETY VALVE** gas side or liquid side or only with the adapter for this valve (see page 26-27)¹⁾.
- **SPECIAL ANTI-PULSATION CONNECTION** liquid side (see page 25)¹⁾.

1) Specify features separately.

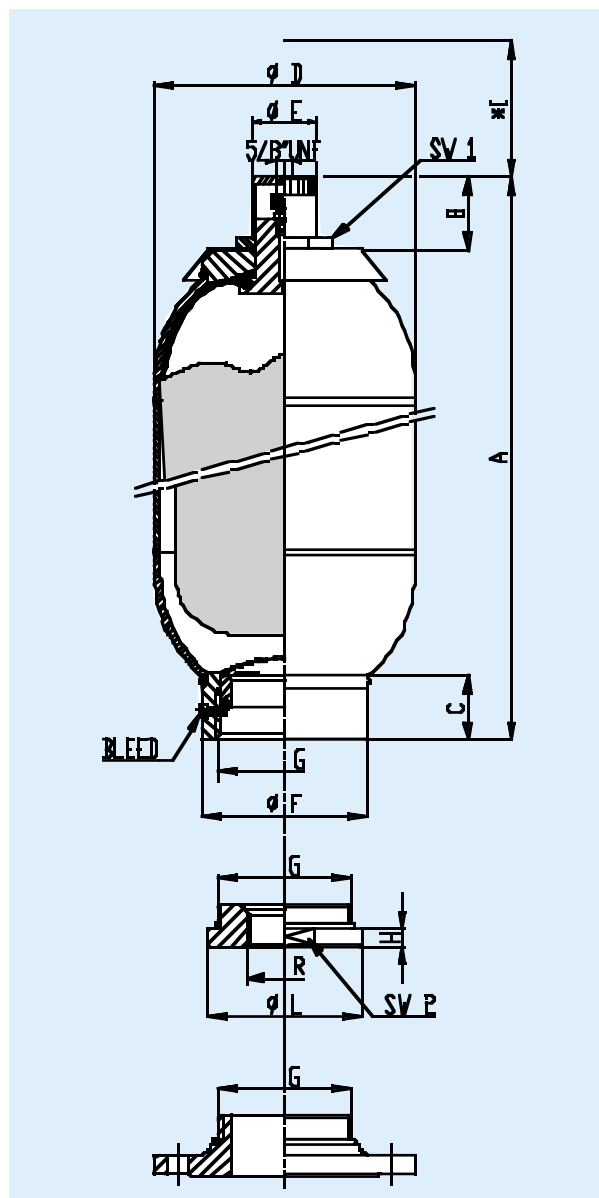
5.3 Dimensions 2)

Type	Max work. pressure (bar)	Gas volume (litres)	Dry weight (kg)	Fluid port connection		A	B	C	ø D	ø E	ø F	H	*I	ø L	SW 1	SW 2
				G ISO 228	R ISO 228											
AS 1,5	80	1,5	6,1	2"	0 = blind	330 ± 3	47	48	114 ± 1	25	75	11	140	74	32	70
AS 3		2,95	9,1		3/4"-1"-1"1/4	510 ± 5										
AS 5		5	15,7		2"1/2	1"-1"1/4-1"1/2										
AS 10	30	9,6	18	4"	0 = blind	475 ± 5	60	50	219 ± 2	55	130	14	140	130	70	120
AS 15		14,5	23		1/2"	615 ± 5										
AS 20		18,8	28		1"1/4	755 ± 8										
AS 25		23,5	33		2" - 3"	900 ± 8										
AS 35		33,5	47			1285 ± 10										
AS 55		50	65			1765 ± 10										

* I = Overall dimensions of pre-loading unit.
 2) = Data related to standard version in carbon steel.

5.4 Components and spare parts

The table 5.4.1 provides a list of accumulator components and, for each model, the part number to be used when ordering; this number is **VALID FOR STANDARD VERSION ONLY**.

For all versions differing from standard it is necessary to give the **manufacturer's serial number and the material**.

Orders for bladder must be carried out as per instructions on Page 37 or giving the accumulator identification code or manufacturer's serial number.

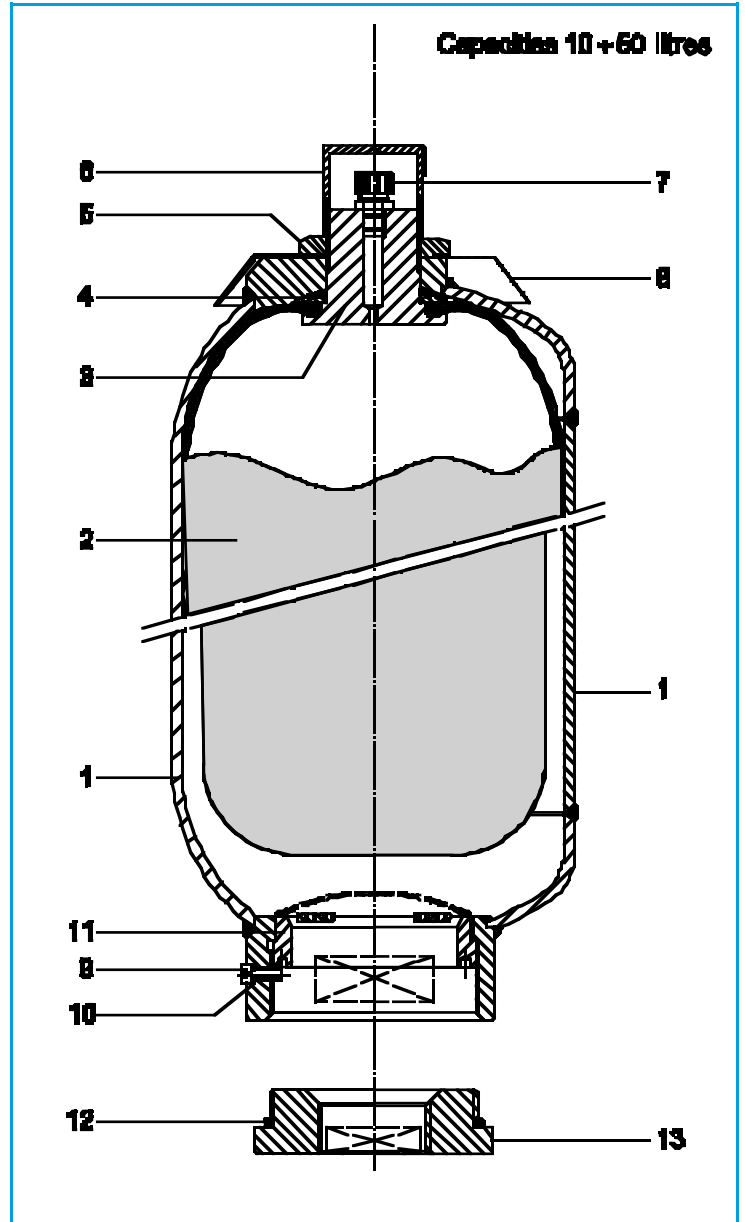
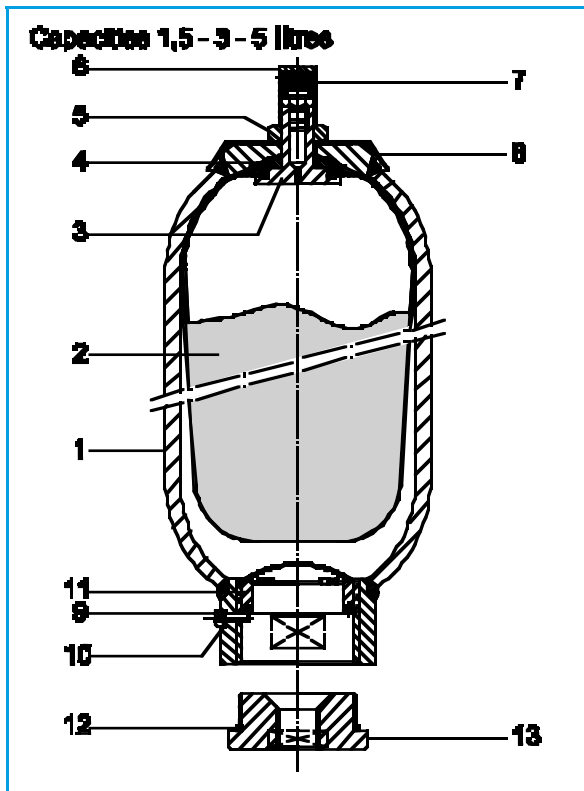

5.4.1 Spare parts list and part number

Item	Description	Pcs.	Models		
			AS 1,5 - 3	AS 5	AS 10-15-20 25-35-50
1	Accumulator shell	1	Not supplied as spare part		
2	Bladder	1	See detailed designation on Page 37		
3	Gas valve body	1	10107	10202	10333
4	Rubber-coated washer	1	10106	10205	10334
5	Gas valve locknut	1	10109		10302
6	Protection cap	1	10103		10301
7	Gas-fill valve	1	2072		
8	Name plate	1	10300-B	10300-C	10300-D
9	Bleed screw	1	10316		
10	Seal ring	1	10336		
11	Anti-extrusion plate	1	10159-1	10241-1	10421-1
12	Adapter "O" ring	1	OR3218	OR3281	OR4425
13	Adapter	1	10323/Ø thread	10244/Ø thread	10444/Ø thread
Gas valve assembly (parts 3-4-5-6-7)			2022	2042	2062
Gasket sets			2032 { OR2050 10341 10342 OR3218	2052 { OR2050 10341 10342 OR3281	2082 { OR2050 10341 10342 OR4425

6.1 Technical features

Max working pressure PS:	4000 p.s.i.
Test pressure PT:	PS x 1,30 p.s.i.
Temperature range min. and max TS:	-40°F ÷ +200°F (-40°C ÷ 93°C) (subject to restrictions due to bladder material)
Nominal capacities:	1/4 gall. ÷ 15 gall. (1 litre ÷ 55 litres)

6.2 Construction features

THE STANDARD VERSION (ASA) INCLUDES:

- Forged steel shell (SA 372 grade E class 70), sandblasted and painted outside with a coat of rust inhibitor.
- Valves in phosphated carbon steel.
- Female SAE threaded fluid port connection.
- Bladder and gaskets in standard nitrile rubber (P).
- Testing and certification according to ASME-U.S. regulations.
- Preloaded with nitrogen at 30 bar (other values available if specified in order).

N.B. Technical features of **ASA** standard version are also valid for **ASAT** and **ASAL** versions except for the structure of gas side valve (see pages 36 and 37).

ON REQUEST the accumulator can be supplied with the following features:

- NICKEL-PLATED SHELL AND VALVES with thickness of 25 microns (Specify other thickness if required).
- SHELL AND VALVES IN STAINLESS STEEL (for working pressures ask to our Technical Department).
- BLADDER IN BUTYL, NEOPRENE, ETHYLENE PROPYLENE, HYDROGENATED NITRILE, NITRILE FOR LOW TEMPERATURE (-40°C), NITRILE FOR HYDROCARBONS, EPICHLOROHYDRIN FOR FOODSTUFF.
- SAE 3000 or SAE 6000 FLUID PORT FLANGED CONNECTIONS (see Page 24 fig. A).
- Fluid port connection female threaded NPT, ISO 228 or metric.
- Adapters with threads to be specified in order.
- Fluid port flanged connections (specify PN and DN in order).

6.3 Spare parts standard version

Type	Gas valve assembly	Fluid port assembly	Bladder complete	Gasket sets	Gas-fill valve	Valve mechanism
ASA 1/4	2376	2024-2	S 1 P 5	2380	2077	2069
ASA 1	2377	2044-2	S 4 P 5	2381		
ASA 2.5	2378	2064-2	S 10 P 5	2382		
ASA 5			S 20 P 5			
ASA 10			S 35 P 5			
ASA 15			S 55 P 5			

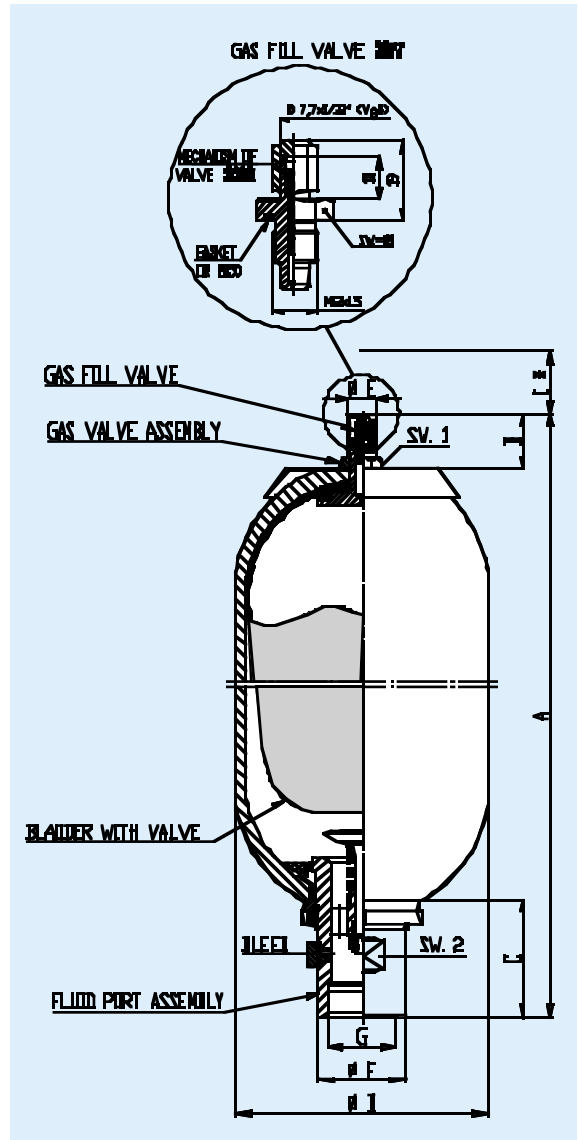

6.4 Identification code

For an accumulator with capacity of 5 gallons, maximum working pressure 4000 psi, bladder in nitrile, shell in SA 372 steel, valves in phosphated carbon steel, standard fluid port connection with SAE thread, ASME-U.S. type approval, the identification code will be: ASA5P4000CS7 (see page 17).

6.5 Dimensions¹⁾

Type	Max working pressure	Nom. nitrogen volume (Gall.)	(Litres)	Dry weight (Kg)	Fluid port connection SAE thread	NPT/BSP thread	A (mm)	B (mm)	C (mm)	øD (mm)	øE (mm)	øF (mm)	*I (mm)	SW 1 (mm)	SW 2 (mm)
ASA 1/4	4000 psi	1/4	1	5,2	SAE 12-1"1/16-12 UN	3/4"	295 ± 5	47	52	114 ± 1	25	36	140	32	50
ASA 1		1	3,5	13	SAE 20-1"5/8-12 UN	1"1/4	392 ± 10								
ASA 2.5		2.5	9	37	SAE 24-1"7/8-12 UN	2"	565 ± 15								
ASA 5		5	19	58			870 ± 15								
ASA 10		10	34,5	96			1382 ± 15								
ASA 15		15	50	133			1905 ± 15								

* I = Overall dimensions of pre-loading unit.
 1) = Dimensions related to the standard version in carbon steel.

7.1 General

Bottles in forged steel, designed as additional nitrogen bottles for bladder or piston accumulators.

7.2 Construction

The ASS version (fig. I) can be supplied with capacity from 0,7 up to 55 litres, both low and high pressure and with all the certifications provided for bladder accumulators except for ASME-U.S.

Dimensions of shells from 0,7 up to 55 litres, not included on the table 7.4, can be deduced for the high pressure range from the table 4.3 and for the low pressure range from the table 5.3.

The ASSA version (fig. I) is provided for shells with ASME-U.S certification, capacity expressed in gallons and pressure expressed in psi.

The BB version (fig. II) is manufactured only with capacity 52 litres and with EC certification.

All the versions are made of hardened and tempered carbon steel, sandblasted, painted outside with a coat of rust inhibitor and are supplied with a plug on the bottom side.

ON REQUEST versions **ASS** and **ASSA** can be supplied with shell nickel coated or internal and external coated with Rilsan. Connections nickel coated or in stainless steel.

On version **BB** the same treatments can be done only on the external surface. Plugs and adapters nickel coated or in stainless steel.

On all the versions can be mounted a bleed or the valve 2072 instead of plug.

7.3 Technical features

Max working pressures:	360 bar 4000 psi (ASME)
Working temperatures:	-40°C ÷ +120°C (ASS) -40°F ÷ +200°F (ASSA) -40°C ÷ +80°C (BB)
Nominal capacity (Fig. I):	10-15-20-25-35-55 litres 2.5-5-10-15 gallons (ASME)
Nominal capacity (Fig. II):	52 litres

Versions ASS and ASSA

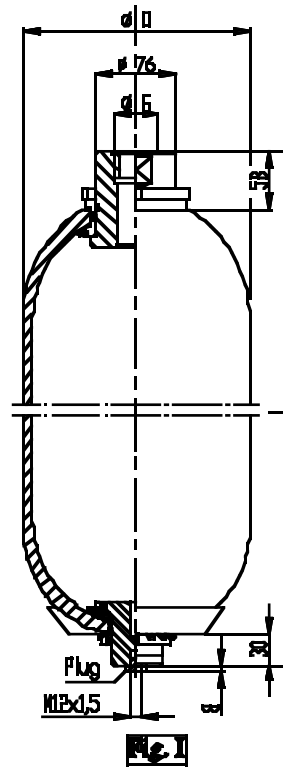

Version BB

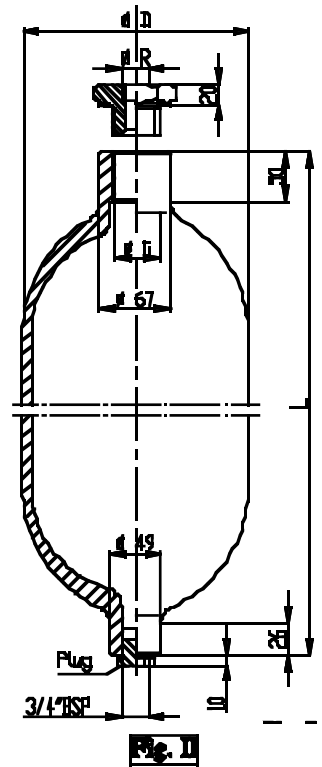

7.4 Dimensions

Type	Max working pressure	Capacity		Weight (Kg.)	Figure	Ø D	Ø G	Ø R	L
		(Litres)	(Gallons)						
ASS 10	360 bar (CE and ML)	10	-	31	I	224 ⁺¹ ₋₄	3/4" BSP 1 1/4" BSP UNI - ISO 228	-	495
ASS 15		15	-	41					645
ASS 20		20	-	45					805
ASS 25		24.5	-	56					970
ASS 35		35	-	74					1320
ASS 55		54	-	102					1837
BB 52	360 bar	52	-	96	II	1 1/2" BSP	1/2" BSP or blind	1760	
ASSA 2.5	4000 psi	-	2.5	35	I	229 ± 1%	SAE 12 1-1/16" - 12 UN SAE 20 1-5/8" - 12 UN	-	503
ASSA 5		-	5	55					808
ASSA 10		-	10	91					1320
ASSA 15		-	15	127					1941

7.5 Identification code

The example shows an additional bottle, type BB with nominal capacity of 35 litres, with a max working pressure of 360 bar; shell and connections in carbon steel; female threaded connection 1 1/2 BSP; EC testing.



Type	Nominal capacity Litres Gallons	Gasket set material (only for ASS and ASSA)	Max working pressure	Material of the shell and connections	Gas connection	Test	Material of connections ¹⁾
ASS = Additional bottle Fig. I	10 2.5	P = Perbunan	360 bar : 97/23/EC ML (ex SQL) ATEX (94/9/EC) AS1210-1997 Gost	C = alloyed steel with rustproof base	G1 = 1-1/4" BSP } ASS G3 = 3/4" BSP } Version	0 = Works 1 = GOST-R 3 = ML (ex SQL) 4 = RINA 5 = BS-LLOYDS REGISTER 6 = Germanischer Lloyd 7 = ASME U.S. 8 = 97/23/EC 9 = ATEX 10 = others to be specified	- = like bottle N = 25 µm nickel-plated X = stainless steel AISI 316
ASSA = Additional bottle ASME version Fig. I	20 10 25 15	F = Nitrile for low temp. H = Nitrile for Hydroc. K = Hydrogenated nitrile A = For food stuffs B = Butyl E = Ethylene-Propylene N = Chloroprene (Neoprene) Y = Epichloridrin	345 bar : RINA B.S. - L.R. Germanischer Lloyd 4000 psi : ASME-U.S.	N = alloyed steel with nickel-plating on the outside only (25 µm) V = alloyed steel with special external painting (to be specified)	S1 = SAE 12 1-1/6" - 12 UN } ASSA S2 = SAE 20 1-5/8" - 12 UN } Version G2 = 1-1/2" BSP } BB R0 = Blind Adapt. } Version R1 = Adapt. 1/2" BSP } A = others to be specified		

1) Specify only if are different from the shell material

Subject to change

8.1 General

In addition to those manufactured with female threaded fluid ports, accumulators can also be supplied with flanged connections. The **high pressure range** is available with fluid port connection (see fig. A and A1) for SAE 3000 and 6000 (capacity 3 ÷ 55 lbs.), or with screwed square flanges (fig. B) or round UNI-DIN-ANSI flanges (fig. C-D). The **low pressure range** is available with UNI-DIN-ANSI flanges (fig. C-D). The order codes are for the **standard version in phosphated carbon steel with nitrile (P) gaskets**. On request, can be done the execution nickel-plated or stainless steel with not standard gaskets.

8.2 Fluid port for SAE flanges

Accumulator model	Fluid port order code	Flange	Work press. (bar)	ø A (mm)	ø B (mm)	ø C (mm)	H (mm)	L (mm)	Gasket OR	Fig.
AS 3 360 bar	2387	1" SAE 6000	360	47.6	38	30.5	9.5	100	4131	A1
	2246	1 1/4" SAE 3000	210	50.8	43	31	8	89	4150	A
	2247	1 1/4" SAE 6000	360	53.3	44	29	10.3	89		A
AS 5 360 bar	2388	1" SAE 6000	360	47.6	38	30.5	9.5	100	4131	A1
	2248	1 1/4" SAE 3000	210	50.8	43	31	8	89	4150	A
	2249	1 1/4" SAE 6000	360	53.3	44	29	10.3	89		A
AS 10 ÷ 55 360 bar	2383	1 1/2" SAE 3000	210	60.3	50	35	8	115	4187	A1
	2268	1 1/2" SAE 6000	360	63.5	51	32	12.5	115		A1
	2271	2" SAE 3000	210	71.5	62	45	9.5	115	4225	A
	2272	2" SAE 6000	360	71.5	67	45	12.5	115		A

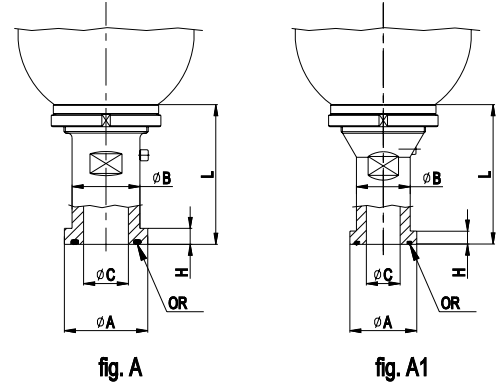

8.3 Square flanges

Accumulator model	Order code	Thread G	ø D (mm)	ø H (mm)	Seal OR	
					radial	frontal
AS 3 - 5 360 bar	10473	1 1/4" ISO 228	26	25	3150	-
	10492	M 40x1.5			-	3168
AS 10 ÷ 55 360 bar	10349	2" ISO 228	32	25	3218	-
	10347	M 50x1.5			-	159
	10448	2" NPT			-	-
ASA 2.5 ÷ 15 4000 p.s.i.	10349-7	1 7/8" - 12 UN			size 24	-

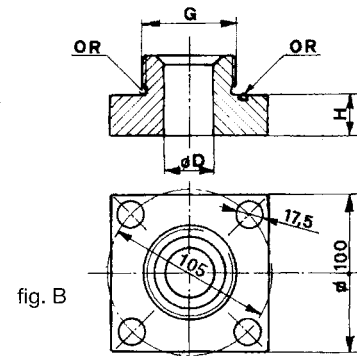

8.4 UNI-DIN-ANSI Flanges

Accumulator model	Order code standard-flanges		mm (inch)	PN bar (lbs)	Fig.	H UNI-DIN-ANSI		G BSP	Seal OR
	UNI-DIN	ANSI				mm	mm		
AS 0,7-1-1,5 360 bar	2205	2207	20 (3/4")	40 (300)	C	23	40	3/4"	2093
	2206	2208				45	59		
AS 3-5 360 bar	2211	2213	25 (1")	40 (300)	D	51	73	1 1/4"	3150
	2212	2214				76	90		
	2215	2217	32 (1 1/4")	40 (300)	C	22	44		
	2216	2218				55	58		
AS 10 ÷ 55 360 bar and AS 1,5-3 80 bar	2221	2224	25 (1")	40 (300)	D	49	67	2"	3218
	2222	2225				51	73		
	2223	2226	40 (300)	250 (1500)	D	76	90		
	2227	2229				56	79		
	2228	2230	50 (2")	64 (400)	C	91	100		
	2231	2234				23	40		
2232	2235	40				55			
AS 5 80 bar	2241	2243	65 (2 1/2")	16 (150)	C	23	45	2 1/2"	3281
	2242	2244				30	52		
AS10 ÷ 55 30 bar	2251	2252	25 (1")	16 (150)	D	52	70	4"	4425
	2255	2257				65	84		
	2256	2258	50 (2")	40 (300)	D	68	90		
	2259	2260				70	90		
	2261	2263	100 (4")	16 (150)	C	31	46		
	2262	2264				44	60		

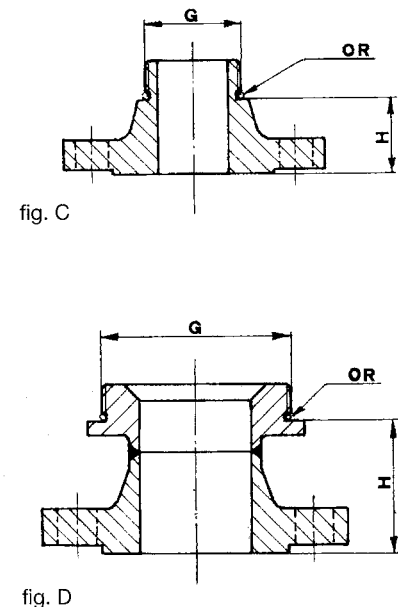

9.1 General

Pulse damper connection is a very useful addition to the bladder accumulator when used as a **pulsations damper**. The flow, due to special construction, is directed inside the accumulator thus greatly increasing efficiency. Construction is such that it can be fitted directly on the liquid connection of all accumulators ranges, both high and low pressure. Versions fig. II, III and IV are for low pressure only. Other pulse dampers, in different sizes, can be supplied on request.

9.2 Construction features

STANDARD VERSION INCLUDES:

- Phosphated carbon steel body.
- Installation side connections: BSP female parallel thread (fig. I and II); with ends for welding neck flange (fig. III and IV).

ON REQUEST:

- BODY NICKEL COATED thickness 25 micron (other thickness to be specified) or in stainless steel.
- FLANGED ENDS (specify DN, PN and standards of flange).

9.3 Operating features

Working pressure:	16 ÷ 80 bar, low pressure 360 bar, high pressure
Temperature range:	-20 ÷ +150°C

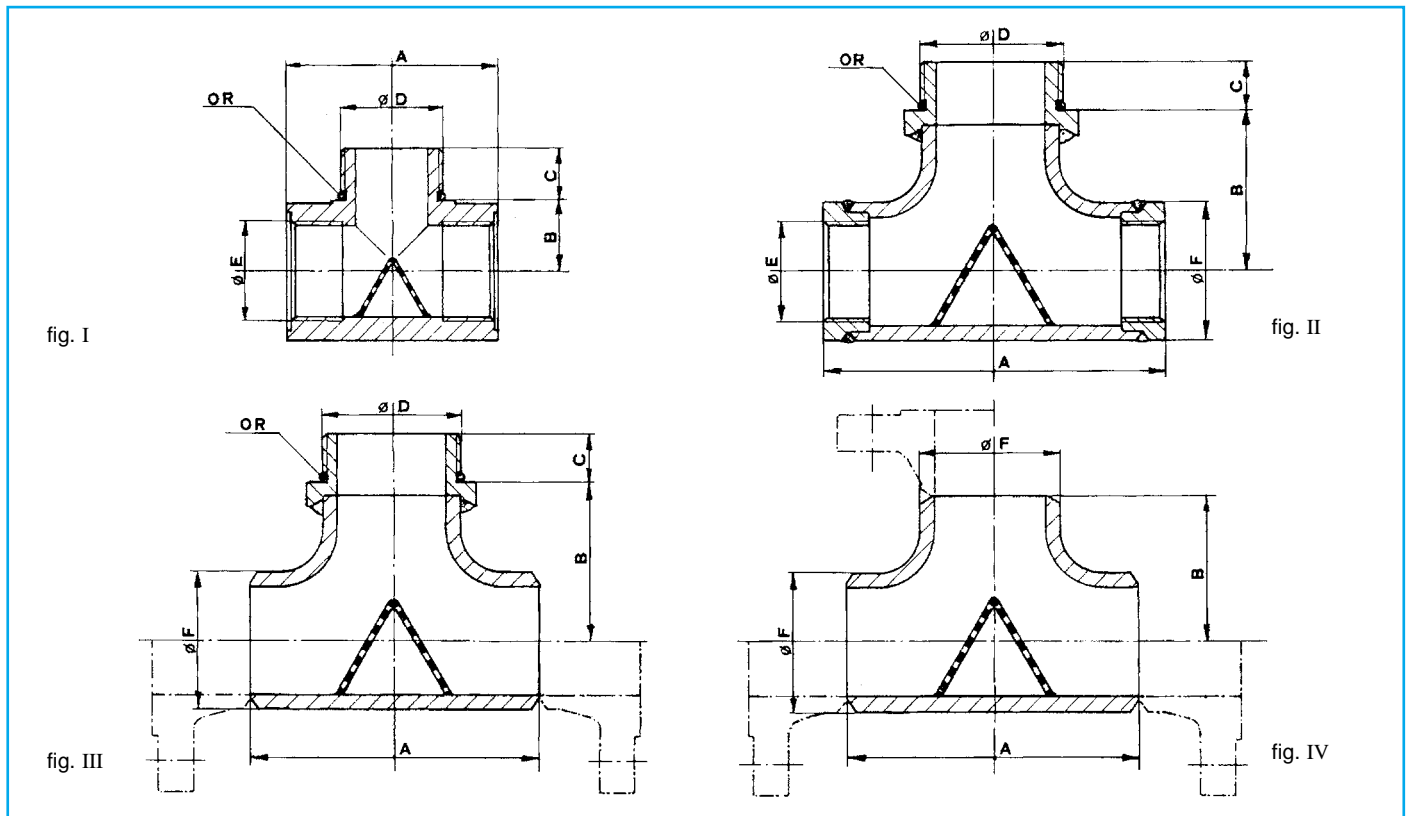

9.4 Dimensions and part number

	High pressure range				Low pressure range								
	AS 0.2	AS 0.7-1-1.5	AS 3-5	AS 10-55	AS 1,5-3			AS 5			AS 10-15-20-25-35-55		
Connection Fig. I - Part No.	2012	2014	2054	2114	-	-	-	-	-	-	-	-	-
Connection Fig. II - Part No.	-	-	-	-	2016	-	-	2056	-	-	2116	-	-
Connection Fig. III - Part No.	-	-	-	-	-	2017	-	-	2057	-	-	2117	-
Connection Fig. IV - Part No.	-	-	-	-	-	-	2018	-	-	2058	-	-	2118
A	46	65	90	120	150	127	127	180	152	152	240	210	210
B	16	19	27	38	70	70	64	82	82	76	112	112	105
C	12	14	18	22	22	22	-	22	22	-	21	21	-
ØD ISO 228	1/2"	3/4"	1"1/4	2"	2"	2"	-	2"1/2	2"1/2	-	4"	4"	-
ØE ISO 228	1/2"	3/4"	1"	1"1/2	1"1/2	-	-	2"	-	-	3"	-	-
ØF	-	-	-	-	60,5	60,3	60,3	73,5	73,1	73,1	114,5	114,3	114,3
OR	10042	2093	3150	3218	3218	3218	-	3281	3281	-	4425	4425	-

10.1 General

The hydraulic system in which the hydropneumatic accumulator is mounted, must have a relief valve installed on the liquid side. This valve should have a **pressure setting equal or lower than the maximum working pressure** marked on the name plate of the accumulator.
The valve must not be used for controlling the system pressure and its setting should only be carried out by authorized personnel.

10.2 Technical and constructional features

Valve DBD... is a direct acting relief valve with conical sealing and it can be adjusted through a screw. If **EC** testing is required, the valve is supplied with **fixed setting and lead seal**. On the execution without certificate the calibration value, marked on the body, indicate the **superior limit** of calibration range; the **lower limit** coincides with the value of the valve just before. It is provided with a protective cap and flat seal. The valve body is in burnished carbon steel; the seals are in Perbunan.

10.3 DBD... relief valve - dimensions

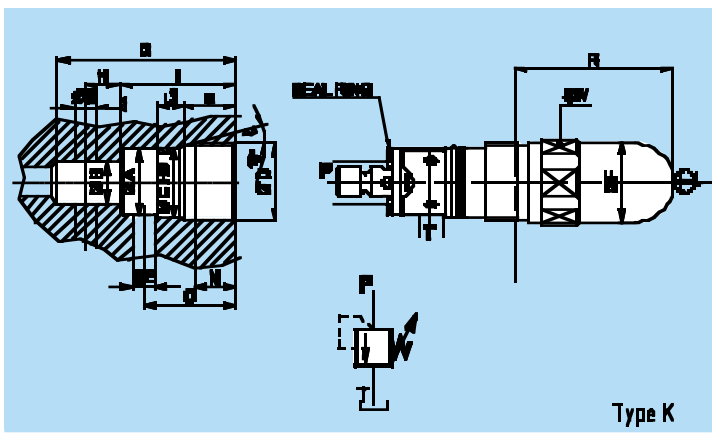

Type	Weight (kg)	øA	øB	øC	øD	øE	øF	G	H	I	L	M	N	O	R	SW
DBD..6...	0,4	24,9	15	25	M28x1,5	6	35	67	11,5±5,5	45	11	19	15	35	70	32
DBD..10...	0,5	31,9	18,5	32	M35x1,5	10	35	80	15,5±7,5	52	12	23	18	41	68	36
DBD..20...	1	31,9	24	40	M45x1,5	20	41	110	21,5±8,5	70	18	27	21	54	66	46

There are three possibilities:

- Cartridge type **DBD...**; this is more frequently used thanks to its practical style and economical advantages (see par. 10.3);
 - Safety valve **VS214/...**; this is used for high flow discharge (par. 11.3);
 - Burst disk **DR8/...**; this is used for narrow spaces and with discharge not conveyed to the tank (see par. 11.4).
- Nominal size: DBD 6 - 10 - 20
 - Standard pressure calibration with CE setting: P=5-630 bar
 - Standard pressure calibration without cert.: P=25-50-100-200-315-400 bar; (630 bar only for DBD10)
 - Overpressure by full flow: 10% of P
 - Blow down: <10% of P
 - Flow rate: max 50lt/1'(DBD6) 120lt/1'(DBD10) 250lt/1'(DBD20)
 - Testing certificate: 97/23/EC

10.4 BPV... blocks for relief valve - dimensions

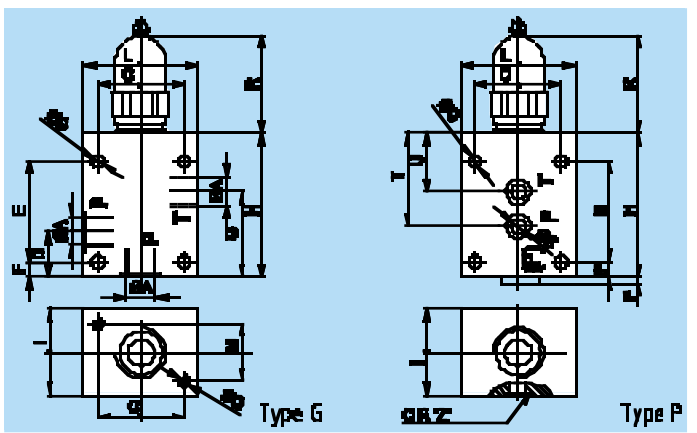

Type	Valve	Weight (kg)	øA (BSP)	øB	C	D	E	F	G	H	I	L	M	P	øQ	S	T	U	Z OR
BPV 6..	DBD..6.. K	1,2	1/4"	6,6	4,5	25	55	10	45	80	40	60	25	3	M6	6	35	55	7x1,5
BPV 10..	DBD..10.. K	3,2	1/2"	9	60	31	70	10	59	100	60	80	40	4	M8	10	41	65	12,3x2,4
BPV 20..	DBD..20.. K	6	1"	9	70	50	100	15	81	135	70	100	50	5,5	M8	20	54	85	22x3

10.5 Identification code

DBD S 10 K 13/ 200 P 8 -

Adjustment method	Nominal size	Mounting method	Operative pressure range	Sealing	Test certification	Material
S = set screw H = handknob A = lockable hand knob (for size 6 and 10 only)	6 = size 6 10 = size 10 20 = size 20	K = cartridge version G = with block BPV TYPE G for threaded connection P = with block BPV TYPE P for subplate mounting	25 = up to 25 bar 50 = up to 50 bar 100 = up to 100 bar 200 = up to 200 bar 315 = up to 315 bar 400 = up to 400 bar 630 = up to 630 bar (for size 10 only) * = on request other calibration with EC	P = fluids on mineral oil base V = fluids on phosphate-ester base	0 = factory testing 8 = 97/23/EC	- = phosphated steel X = stainless steel

10.6 BAPV 10 accumulator block for DBDS10K...

This block is used for the assembling of the valve DBD..10... It is made of burnished carbon steel. The two connections **P** and **P1** are used indifferently for the connection to the accumulator through a nipple and to the system. The discharge line **T** mustn't have counterpressures and must have a free passage.

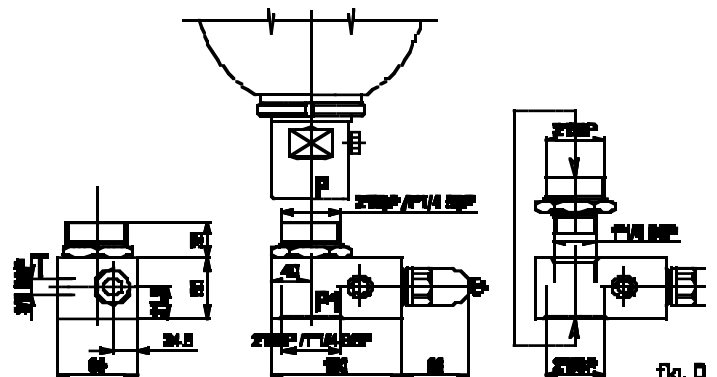

11.1 General

These valves and burst disks are mounted in order to protect the accumulator in case of gas overpressures higher than the value of the maximum allowable working pressure.

So the **calibration** of the valve or of the burst disk **must be equal or lower than this value**.

Are available the following types: valves VS214/... with EC testing (ISPESL on request) and burst disks DR8/... with EC testing (others on request).

For the **designation** merely add the setting pressure and the type of testing to the valve code.

11.2 Installation

The valve or the burst disk must be mounted close to the gas valve and in direct contact with the nitrogen contained into the accumulator. In particular cases are installed on the fluid side (see page 26-28-29-30-31).

Each type of valve or of burst disk can be supplied with adapter for a direct mounting on the different types of gas valves.

A shut-off cock between accumulator and valve is allowed only if it is sealed in "open" position.

Before mounting, be sure that the accumulator is completely discharged.

11.3 Safety valve type VS214/... (with related adapters)

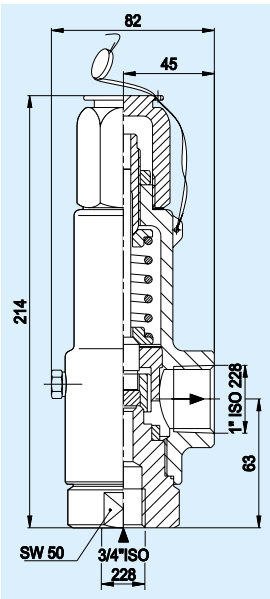

Technical and constructional features

This valve is characterised by a port size of 9,5 mm. and by a copra-aluminium disc with flat seat. Seals are not provided; valve tightness is ensured by an accurate lapping of disc surfaces. The body is made of steel A105, the disc is made of AISI 431.

- Port size : Ø 9.5 mm
- Calibrations P : up to 413 bar on request
- Overpressure by full flow : 10% of P
- Blow down : 7% of P
- Lift mm 2,1 : fluid nitrogen
- Spring adjustment : ± 5% calibration
- Gas discharge coefficient : K = 0,95
- Liquids discharge coefficient: K = 0,6
- Temperatures range : min. -20°C max +150°C
- Test certificate : 97/23/EC (ISPESL on request)

Gas side adapters

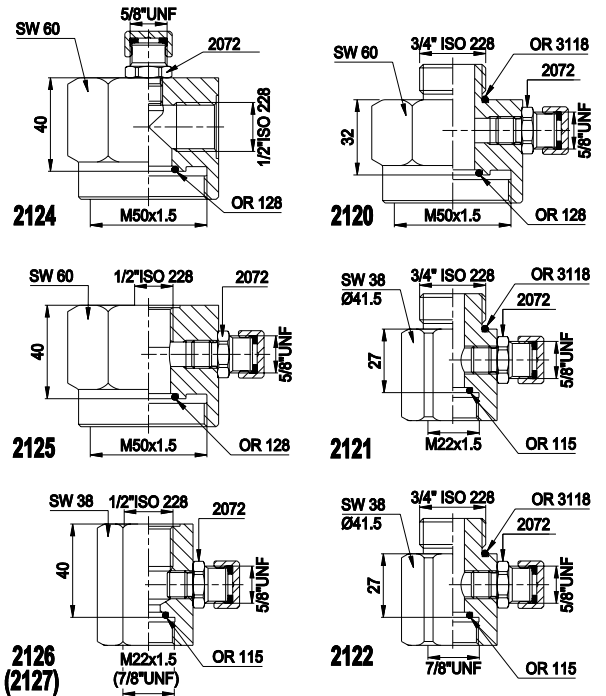

11.4 Burst disk type DR8/... (with related adapters)

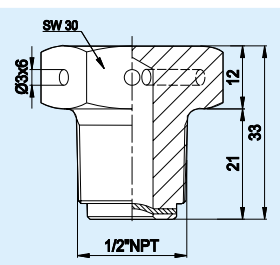

Technical features

- Materials : AISI 316L
- Port size : 6 holes Ø 3
- Calibration : on request
- Overpressure : ± 10%
- Temperature range : min. -40°C max +150°C
- Test certificate : 97/23/EC

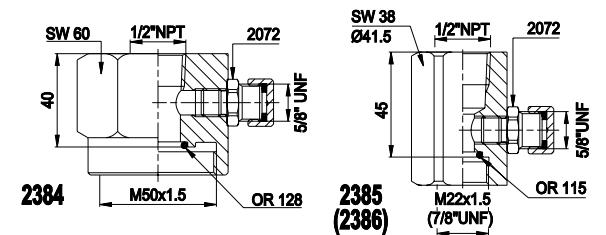

11.5 Some gas side adapters for the connection of valves and manometers ¹⁾

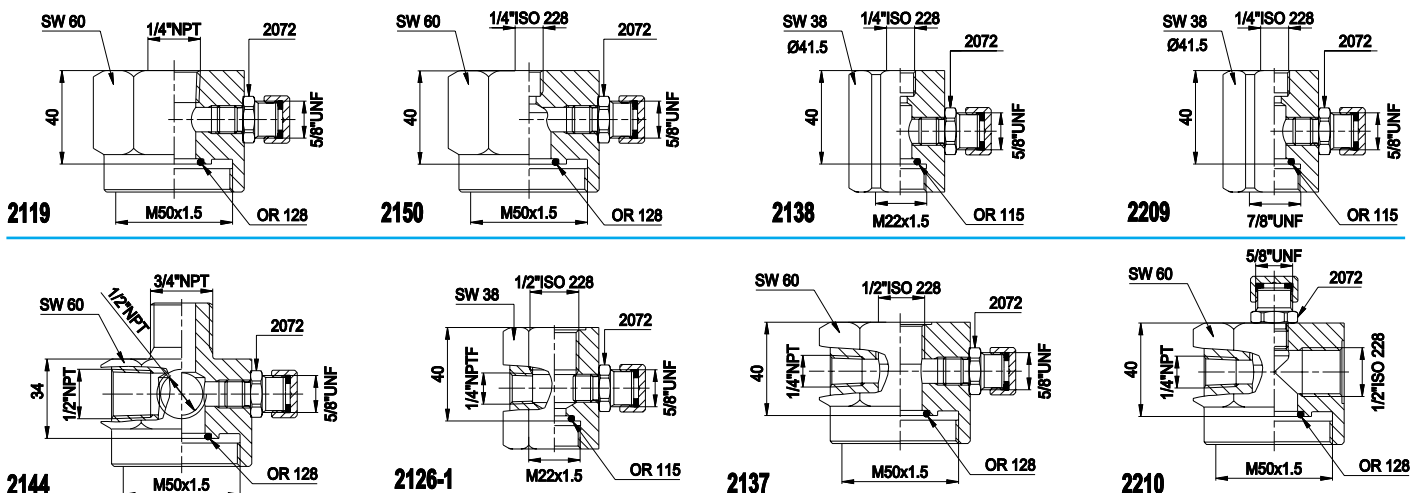

1) Other versions on request

12.1 General

Safety blocks series B10-20 combine in a compact unit all the components required for an easy **connection** of accumulator on an hydraulic circuit and its **protection** from overpressure.

They also allow a quick disassembly of the accumulator or a check of accumulator pre-charge pressure also when the system is operating. Series **B10-B20** is suitable for accumulators from **0,7 litres up to 55 litres**.

12.2 Construction

STANDARD VERSION INCLUDES:

- Phosphated steel body.
- **3-way** ball valve, in chrome-plated steel, connecting accumulator to inlet or discharge.
- Seat for assembling of relief valve.
- Installation side connection, BSP female parallel threaded ISO 228.
- Accumulator side connection, metric female parallel threaded.
- Flow control valve for adjusting the flow rate during the accumulator discharge (Only on B20).
- Discharge and manometric connections.
- Gaskets for mineral oil (Perbunan).

ON REQUEST it is supplied with:

- BODY nickel-coated; relief valve in stainless steel.
- NIPPLE for connection to accumulator.
- PLUG no. 2375 for closing of valve seat.
- RELIEF VALVE TYPE DBDS not adjusted (see page 26).
- RELIEF VALVE TYPE DBDS sealed with lead and EC certified.
- VALVE TYPE VS214/... with ISPESEL certificate or EC (see page 27).
- TWO-WAY SOLENOID VALVE for electrical discharge, "normally open".
Technical features (voltage, frequency, etc.) or version "normally close" have to be specified.
- GASKETS IN VITON.



12.3 Technical features

Diameter of inlet port:	Ø 10 or 20 mm.
Nominal flow rates at ~ 10 m/s:	B10 = 50 l/min; B20 = 190 l/min
Max. working pressure:	360 bar
Temperature range:	- 20 ÷ +80°C standard (70°C with electrovalve) - 20 ÷ +150°C (seals in Viton)
Relief valve:	- Ø flow = 10 mm. - DBDS not adjusted (see chapter 10.2) - DBDS adjustable from 5 to 360 bar with EC certification - VS214/... with EC or ISPESEL certification
Solenoid valve:	- Power voltage = DC 24V - 110 V AC 110/220V - Power consumption = 26W - Protection = IP65

12.4 Identification code

The example shows a safety block series B, with inlet port 20 mm, with only manual discharge, with relief valve type DBDS tested by EC at 360 bar, accumulator side connection 2" BSP, installation side connection 3/4" BSP, gaskets in Perbunan, block in phosphated steel. (If the solenoid valve will be installed, specify electrical data in detail).



Type and inlet port	Discharge	Relief valve (see pages 26-27)	Valve calibration (bar)	Accumulator side connection	Installation side connection	Gasket material	Block material
B 10	M = Only manual	A = without valve with plastic plug B = valve type DBDS... (Not adjusted) C = valve type VS214/... (ISPESEL certified) P = valve type DBDS... (EC certified) V = valve type VS214/... (EC certified) T = without valve (with plug 2375)	Valves type DBDS10 or VS214 adjusted with certificate 5 ÷ 360 Valves DBDS10 not adjusted* 25 - 50 - 100 200 - 315 - 400 (*superior limits of regulation range)	G = 2" BSP G1 = 1"1/4 BSP G3 = 3/4" BSP M = M 50x1,5 M1 = M 40x1,5 G = 2" BSP G1 = 1"1/4 BSP M = M 50x1,5 M1 = M 40x1,5 H = without nipple S = SAE thread A = other	B10 R = 1/2" BSP female B20 R = 3/4" BSP female	P = Nitrile V = Viton	- = Phosphated steel N = Nickel coated steel 25 µm

12.5 Spare parts No.

In addition to the spare part number specify the complete block designation or its serial number, especially for non-standard version.

Type	Accumulator side connection Ø A					Ball of shut off valve with gaskets	Relief valve DBDS not adj. (without testing)	Relief valve DBDS adjusted (with cert. EC)	Safety valve Testings		Gaskets sets
	3/4" BSP	1"1/4 BSP	2" BSP	M40x1,5	M50x1,5				EC	ISPESEL	
B 10	10450	10451	10452	10453	10454	2132	2105/(bar)*	2106/(bar)/EC	VS214/(bar)/EC	VS214/(bar)/ISPESEL	2140
B 20	-	10470	10471	-	10472	2133		

*Choose, among limits of regulation range, the value just higher than working pressure

Subject to change

12.6 Dimensions

- BLOCK TYPE B10
- MANUAL DISCHARGE

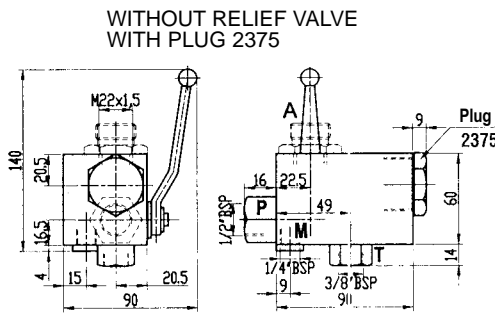
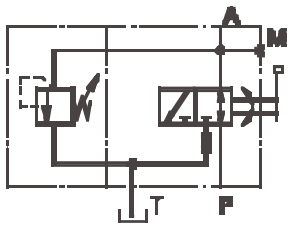

- WITH RELIEF VALVE DBDS10
- NOT ADJ. OR "€€" TESTING

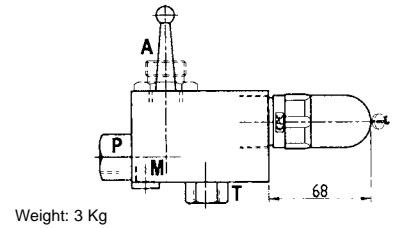

- BLOCK TYPE B10
- WITH RELIEF VALVE
- WITH ELECTR. & MANUAL DISCHARGE

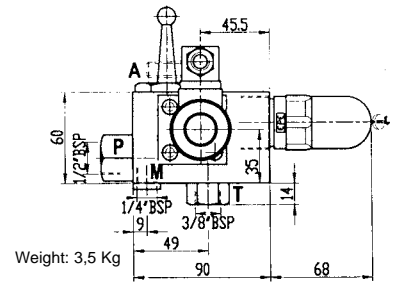
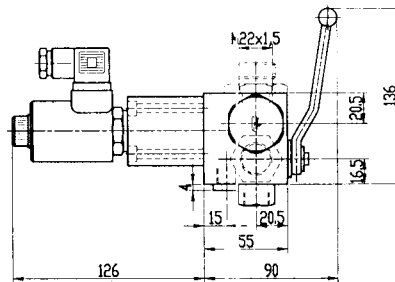
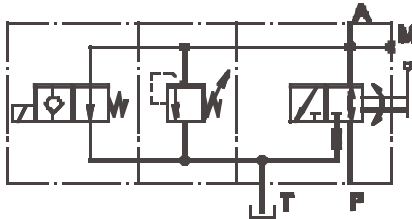

- BLOCK TYPE B20
- MANUAL DISCHARGE

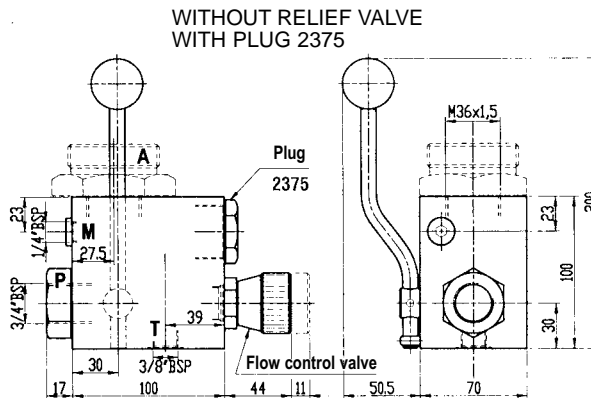
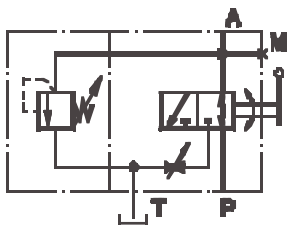

- WITH RELIEF VALVE DBDS10
- NOT ADJ. OR "€€" TESTING

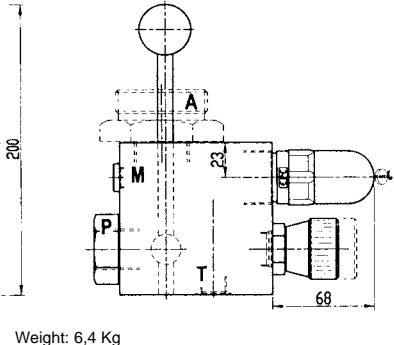

- BLOCK TYPE B20
- WITH RELIEF VALVE
- WITH ELECTR. & MANUAL DISCHARGE

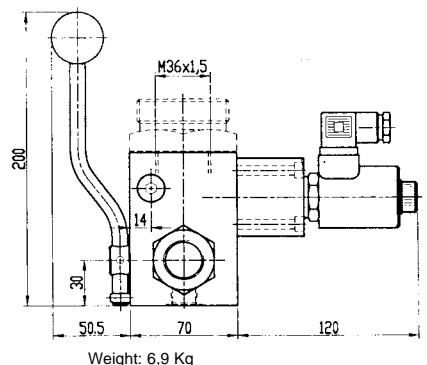
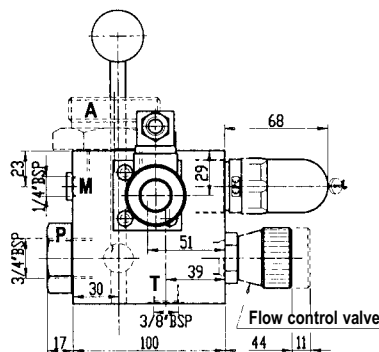
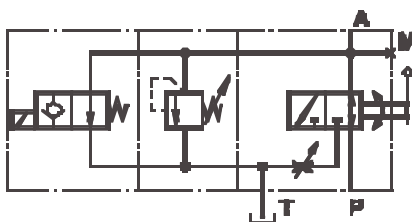

- DBDS RELIEF VALVE
- CERTIFICATION ACCORDING TO DIRECTIVE 97/23/EC

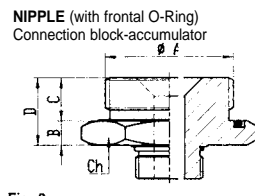
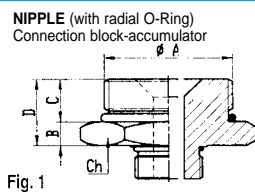
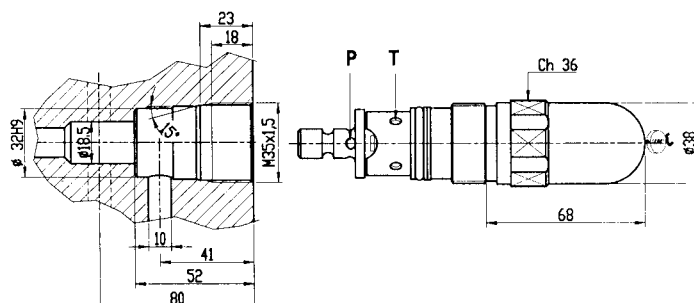

Order No.	Type	Fig.	Ø A	B	C	D	Ch
10450	B10	1	3/4" BSP	8	14	20	36
10451		1	1" 1/4 BSF	8	14	20	50
10452		1	2" BSP	8	16	24	70
10453		2	M40x1,5	8	14	20	50
10454	B20	2	M50x1,5	8	16	24	70
10470		1	1" 1/4 BSF	10	16	26	50
10471		1	2" BSP	10	20	30	70
10467		2	M40x1,5	10	16	26	50
10472	2	M50x1,5	10	20	30	70	

Subject to change

13.1 General

Safety blocks series BS25-32 combine in a compact unit all the components required for an easy **connection** of accumulator on an hydraulic circuit and its **protection** from overpressure.

They also allow a quick disassembly of the accumulator or a check of accumulator pre-charge pressure also when the system is operating.

Series **BS25-32** is suitable especially for applications with accumulators of **10 + 55 litres** where are required **big flow-rates**.

13.2 Construction

STANDARD VERSION INCLUDES:

- Phosphated steel body.
- Shut off ball valve DN25 or DN32.
- Valve for accumulator discharge.
- Discharge connection T 3/8" BSP lateral (see page 31).
- Seat for assembling of relief valve.
- Installation side connection, BSP female parallel thread.
- Accumulator side flange, 2" BSP male parallel threaded.
- Discharge and manometric connections.
- Gaskets for mineral oil (Perbunan).

ON REQUEST it is supplied with:

- BODY nickel-coated or stainless steel; relief valve in stainless steel.
- PLUG no. 2375 for closing of valve seat.
- RELIEF VALVE TYPE DBDS not adjusted (see pag. 26).
- RELIEF VALVE TYPE DBDS sealed with lead and EC certified.
- VALVE TYPE VS214/... with ISPEL certificate or EC (see page 27).
- TWO-WAY SOLENOID VALVE for electrical discharge, "normally open".
Technical features (voltage, frequency, etc.) or version "normally close" have to be specified.
- CONNECTION T1 installation side (see pag. 31).
- INSTALLATION SIDE CONNECTION for SAE and CETOP flanges.
- FLANGE on accumulator side different from 2" BSP.
- FLANGE on installation side (to be specified in detail).
- GASKETS IN VITON.



13.3 Technical features

Diameter of inlet port:	Ø 25 or 32 mm.
Nominal flow rates at ~ 6 m/s:	BS25 = 180 l/min; BS32 = 290 l/min
Max. working pressure:	400 bar
Temperature range:	- 20 ÷ +80°C (70°C with electrovalve) - 20 ÷ +150°C (seals in Viton)
Relief valve:	- Ø flow = 10 mm. - DBDS not adjusted (see chapter 10.2) - DBDS adjustable from 5 to 400 bar, EC cert. - VS214/... adjustable from 5 to 400 bar with EC or ISPEL certification
Solenoid valve:	- Power voltage = DC 24V - 110 V AC 110/220V - Power consumption = 26W - Protection = IP65

13.4 Identification code

The example shows a safety block series BS, inlet port 25 mm, with manual discharge only, lateral discharge connection standard T 3/8" BSP, with relief valve type DBDS with EC testing calibrated at 360 bar, accumulator side connection 2" BSP, installation side 1" BSP, gaskets in Perbunan, block in phosphated steel. (If the solenoid valve will be installed, specify electrical data in detail).

BS25 M P 360 G R P - - -

Type and inlet port	Discharge	Relief valve (see pages 26-27)	Valve calibration (bar)	Accumulator side connection Ø A	Installation side connection	Gaskets material	Block material	Discharge connection position
BS 25	M = Only manual	A = without valve, with plastic plug B = valve type DBDS... (not adjusted) C = valve type VS214/... (ISPEL certified) P = valve type DBDS... (EC certified) V = valve type VS214/... (EC certified) T = without valve (with plug 2375)	Valves type DBDS10 or VS214 adjusted with certificate 5 ÷ 400 Valves DBDS10 not adjusted* 25 - 50 - 100 200 - 315 - 400 (superior limits of regulation range)	H = without flange G = 2" BSP G1 = 1"1/4 BSP M = M 50x1,5 M1 = M 40x1,5 P = 2" NPT S = SAE thread (to be specified) A = other (to be specified)	R = BSP female par. thread S = SAE drilling ¹⁾ C = CETOP drilling ¹⁾ FS = with SAE flange ¹⁾ FC = with CETOP flange ¹⁾	P = Nitrile V = Viton	- = Phosphated steel N = Nickel-coated steel 25 µ X = Stainless steel	- = Lateral standard T=3/8" BSP 1 = Installation side T1 Ø 5 (see page 31)

1) Specify flange data in detail.

13.5 Spare parts No.

In addition to the spare part number specify the complete block designation or its serial number, especially for non-standard versions.

Type	Accumulator side flange Ø A					Ball of shut off valve with gaskets	Complete valve for manual discharge	Relief valve DBDS without certif.	Relief valve DBDS with cert. EC	Safety valve EC or ISPEL	Gaskets sets
	2" BSP	1"1/4 BSP	M50x1,5	M40x1,5	2" NPT						
BS 25	10349	10473	10347	10492	10448	2134	2152	2105/(bar)*	2106/(bar)/EC	VS214/(bar)/...	2142
BS 32	-	-	-	-	-	2135					2143

*Choose, among limits of regulation range, the value just higher than working pressure

Subject to change

14.1 General

The block series BC is used in order to make safer and more practical the connection of one or more additional nitrogen bottles with a bladder accumulator “transfer” version or with a piston accumulator. It includes substantially the following equipment:

- Shut-off valve **R** that remains open during the operation in order to assure the free nitrogen flow between bottles and accumulator and vice versa; it should be closed only for a check or for the accumulator maintenance.
- Check valve **VR** that guarantee the nitrogen passage from accumulator to bottles even when the cock **R** is wrongly closed.
- Safety valve **VS214** or burst disk for the protection of overpressures.
- Filling valve **PC** for the charging or the check of nitrogen pre-charge through pre-loading set PC250S1.

14.2 Construction features

THE BASIC VERSION INCLUDES:

- Body in phosphated steel with shut-off valve (**R**) and check valve (**VR**).
- Nipple for safety valve.
- Female threaded nipple on accumulator side (**A**) and gas side (**B**).
- Female threaded nipple for manometer (**M**).
- Valve with connection for pre-loading and checking set PC250S1.
- Gasket sets in NBR (Perbunan P).

ON REQUEST:

- Body in nickel-plated carbon steel.
- Safety valve with EC or ISPESEL testing.
- Burst disk with EC testing.
- Gaskets in VITON.
- Pressure gauge with possible isolator valve (to be specified in detail).

14.3 Identification code

The example given below shows a BC block made of phosphated steel, with 25 mm port, safety valve tested by EC and calibrated at 210 bar, a “1” BSP connection both on the accumulator and on the bottle side, Perbunan gaskets.



Type	Safety valve or burst disk	Calibration (bar)	Connection sides A and B	Gaskets material	Surface treatment
BC 25	A = without valve C = with VS214/... valve with ISPESEL certificate V = with VS214/... valve with 97/23/EC certificate R = with burst disk	5 ÷ 400 (calibration value indicated by the user)	G = “1” BSP (Standard) A = Other to be specified	P = Perbunan V = Viton	- = phosphated steel N = Nickel-plated steel 25 µm

14.5 Spare parts No.

In addition to the spare part number it is essential to indicate also the complete identification code of the block or its serial number.

Type	Valve with gaskets	Check valve	Gas filling valve	Safety valve ISPESEL tested	Safety valve EC tested	Burst disk EC tested	Gaskets
BC 25	2134	2305	2072	VS214/(bar)/ISPESEL	VS214/(bar)/EC	DR8/(bar)	2304

Subject to change

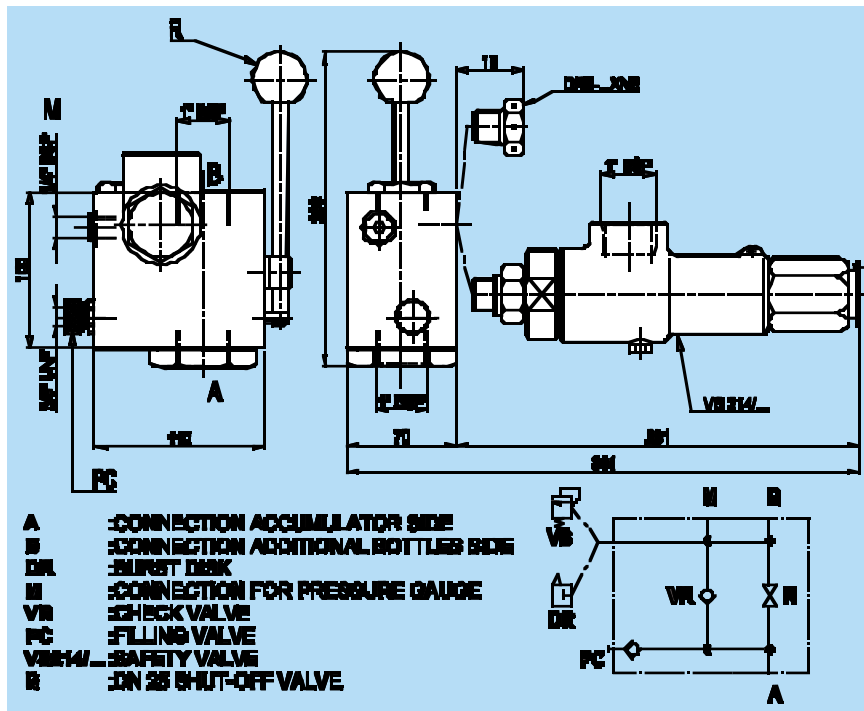

14.3 Technical features

Port:	25 mm.
Max working pressure:	400 bar
Working temperature:	-20°C / +80°C (+150°C with Viton seals)
Safety valve:	VS214/... with EC or ISPESEL certification and calibrated at the value indicated by the user
Burst disk:	DR8/... with EC certification

15.1 General

The fixing must be done in such a way as to not lie with outward stresses on the shell or on the accumulator connection. Especially for the horizontal assembling and for the most heavy types is necessary to use fixing equipments (clamps, brackets, etc...) that support the accumulator and avoid dangerous vibrations.

15.2 Construction

Clamps and brackets are manufactured of galvanized carbon steel but, on request, they can be supplied entirely in stainless steel. The support ring are of nitril rubber 80°Sh. On request can be used other elastomers.

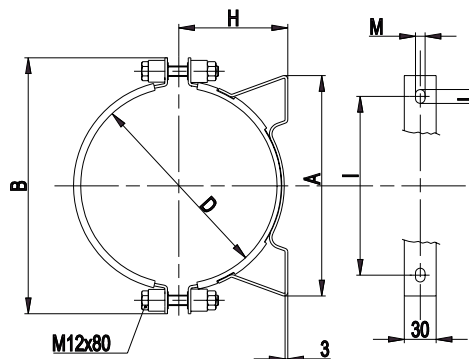
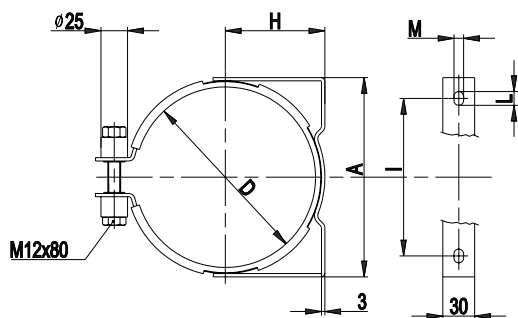
15.3
Clamps

Dimensions and order code

Accumulator Type	Accumulator Max. press. (bar)	Order code	Fig.	Weight (kg)	A	B	D	H	I	L	M
AS 0,7	360 - 550	10155	I	0,65	125	—	89 ÷ 93	53 ÷ 55	90	13	9
AS 1-1,5-3	80 - 360	10157	II	0,85	135	194	114 ÷ 122	66 ÷ 70	100	13	9
AS 5	80 - 360	10250	II	1,1	185	251	167 ÷ 176	95 ÷ 100	146	13	9
AS 10 ÷ 55	30 - 360	10410	II	1,35	298	285	215 ÷ 227	120 ÷ 126	216	20	10

15.4 U-Bolt clamps and plastic pipe saddles
Dimensions and order codes

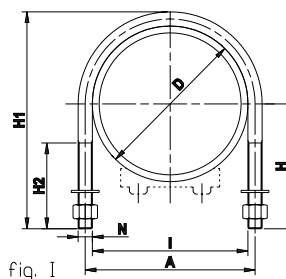
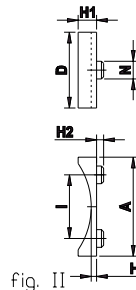
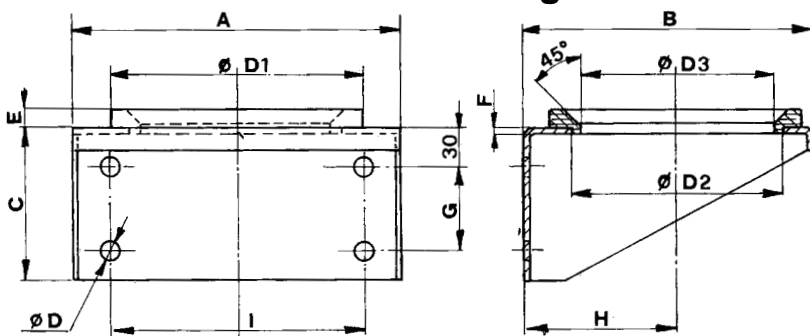
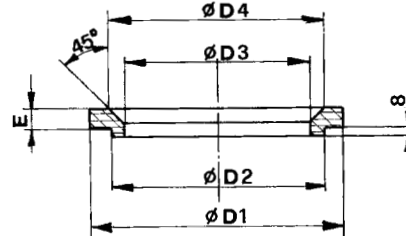
Accumulator Type	Order code	Fig.	Weight (kg)	A	D	H	H1	H2	I	N
AS1 - 1,5 - 3	11468	I	0.12	123	115	84	149	35	115	M8
ASA 1/4	11475	II	...	75	70	8	17	10	40	15
AS 5	11469	I	1.74	178	168	118	211	45	168	M10
ASA 1	11476	II	...	140	75	8	26	10	90	25
AS 10:55 ASS 10:55	11470	I	2.75	236	220	157	282	60	220	M16
ASA 2.5:15 BB52	11477	II	...	140	75	8	26	10	90	25

U-Bolt clamps

Plastic pipe saddles

15.5
Bracket with ring

Support ring

Dimensions and order code

Accumulator Type	Order code Bracket with ring	Order code Support ring	Weight (kg)	A	B	C	ø D	ø D1	ø D2	ø D3	ø D4	E	F	G	H	I
AS 5	10263		1,5	200	175	90	11	140	120	90		10	3	40	96	140
AS 10 ÷ 55	10363		3,6	260	232	120	17	200	170	150		15	3	70	125	200
AS 1 ÷ 5		10266	0,13					140	120	90	112	10				
AS 10 ÷ 55		10345	0,22					200	170	150	175	15				

16.1 General

It is used for the periodic check of accumulator pre-charge and for the inflation of accumulators themselves after the replacement of the bladder or it is used for the change of pre-charge value. For the inflation is necessary a connection to a bottle filled with industrial dry nitrogen with a pressure higher than the precharge value required, provided with **pressure reducer** (mandatory, for safety reasons, during the inflation of accumulators with PS < 210 bar). Furthermore the use of a pressure reducer make easier the **slow and graduated** inflow of nitrogen on the bladder avoiding in this way the possibility of damaging of the bladder itself.

16.2 Construction

STANDARD VERSION includes:

- Valve body complete with ring nut connection to accumulator gas valve, pressure gauge, bleed and non return snap-in hose connection.
- 3 m charging hose for high pressure series complete with bottle connections.
- One connection nipple to pressure reducer.
- Set of spare gaskets.
- Case.

ON REQUEST:

- ADAPTER for special accumulator gas valves.
- CHARGING HOSE with lenght of 6 m.



16.3 Technical features

Max working pressure: 600 bar

Accumul. connection: 5/8" UNF (standard)
7/8" UNF; ø 7,7x1/32" (Vg8); 1/4" ISO 228; (on request)

Bottle connection: See designation (ch 16.5), drawings and table ch. 16.7 page 35

Pressure gauges: - Ø 63 connection 1/4" ISO 228
- Full scale 250 bar for high pressure accumulators
- Full scale 25 bar for low pressure accumulators

Weight: 1,8 kg (case included)

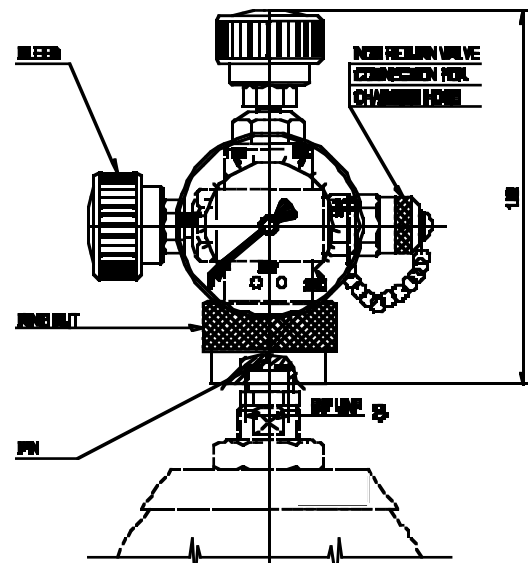

16.4 Spare parts

Gasket set	2160	Complete bleed	2164
Non-return valve	2162	Charging hose	2166/(metres)
Central pin	2165	Pressure gauge	2163/(bar)

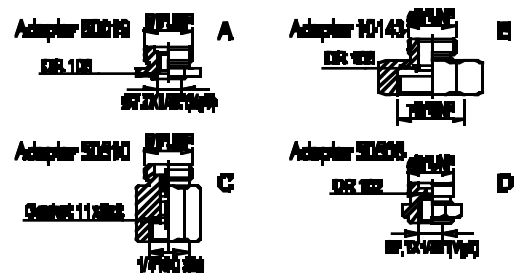

16.5 Identification code

The example below shows equipment for filling and checking with pressure gauge of 250 bar, with accumulator connection 5/8" UNF and standard bottle connection, complete with 3 m hose and case.

SAMPLE OF DESIGNATION:

PC 250 S 1 - -

Type	Pressure gauge (bar)	Connection to accumulator	Connection to bottle ¹⁾ (according to Country standards)				Charging hose (metres)
PC Pre-loading and checking	25	S = 5/8" UNF (standard) A = ø 7,7x1/32" (Vg8) (adapter 50019) B = 7/8" UNF (adapter 10143) C = 1/4" ISO 228 (adapter 50510) D = ø 7,7x1/32" (Vg8) (long thread) (adapter 50508)	1 = Italy 2 = Austria Czech Republic Denmark Finland Germany Netherlands Norway Poland Sweden Switzerland	3 = Belgium Egypt France Hungary Mexico Morocco Romania Saudi Arabia Slovenia Spain Tunisia	4 = Argentina Australia Great Britain Greece India Indonesia New Zeland Philippines Portugal Singapore Turkey	5 = Brazil South America 6 = South Africa 7 = Canada USA 8 = Russia Venezuela 9 = Japan 10 = Taiwan 11 = China 12 = Korea	- = 3 m (standard) L = 6 m (on request)

1) Other types on request

16.6 Connection charging hose - pressure reducer

The use of pre-loading set for the inflation of accumulators "low pressure" series requires, for safety reasons, the use of a **pressure reducer mounted on the nitrogen bottle** calibrated at a pressure equal or lower than the max working pressure PS marked on the accumulator body. The connection nipple between charging hose and reducer it is showed by the side of the page and it is normally supplied with the pre-loading set.

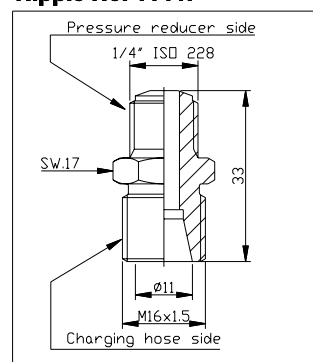
Nipple No. 11447

16.7 Connection charging hose - additional bottle

For "high pressure" accumulators and, in general, for all the types with PS ≥ 210 bar, it is possible to connect the nitrogen bottle through the proper nipple without the use of pressure reducer.

The proper nipple has to be chosen according to the origin Country of nitrogen bottle, as showed on the table below.

The number of the column indicated with **x** stands for the fig. of the nipple valid for such Country and coincide with the number used for the indication of bottle connection in the designation code (ch. 16.5).

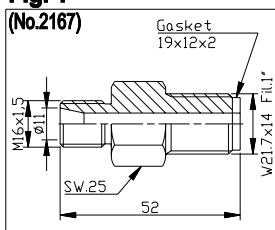
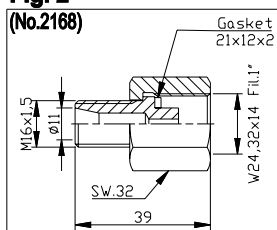
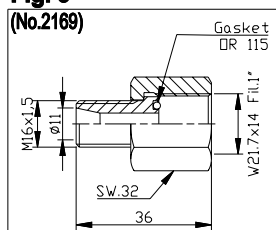
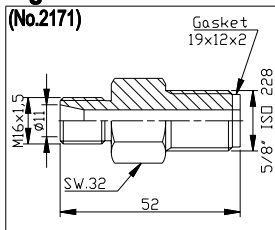
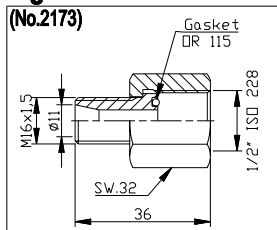
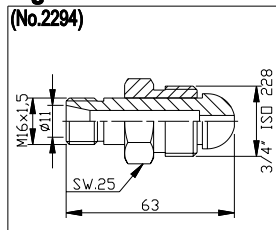
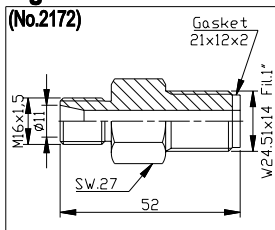
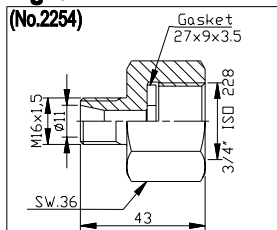
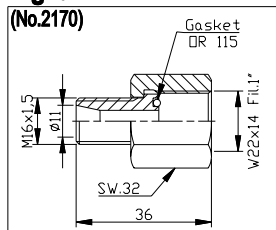
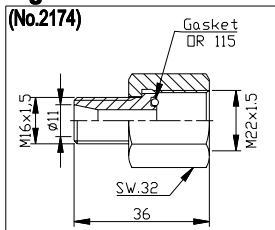
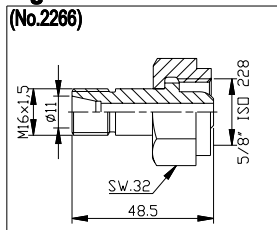
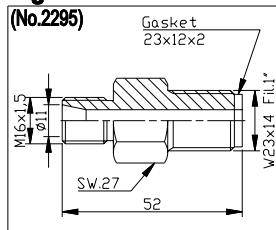
Each nipple has an own code (indicated on) to be used for spare parts order and not on the designation of the pre-loading set.

Fig. 1
(No.2167)

Fig. 2
(No.2168)

Fig. 3
(No.2169)

Fig. 4
(No.2171)

Fig. 5
(No.2173)

Fig. 6
(No.2294)

Fig. 7
(No.2172)

Fig. 8
(No.2254)

Fig. 9
(No.2170)

Fig. 10
(No.2174)

Fig. 11
(No.2266)

Fig. 12
(No.2295)

COUNTRY	Fig. No.											
	1	2	3	4	5	6	7	8	9	10	11	12
Argentina				X								
Australia				X								
Austria	X											
Belgium	X											
Brazil					X							
Canada						X						
China											X	
Czech Republic	X											
Denmark	X											
Egypt			X									
Finland	X											
France			X									
Germany	X											
Great Britain				X								
Greece				X								
Hungary			X									
India				X								
Indonesia				X								
Italy	X											
Japan									X			
Korea											X	
Mexico			X									
Morocco			X									
Netherlands	X											
New Zealand				X								
Norway	X											
Philippines				X								
Poland	X											
Portugal				X								
Romania			X									
Russia								X				
Saudi Arabia			X									
Singapore				X								
Slovenia			X									
South Africa					X							
South America					X							
Spain			X									
Sweden	X											
Switzerland	X											
Taiwan										X		
Tunisia			X									
Turkey				X								
USA					X							
Venezuela								X				

Subject to change

17.1 General

The EPE bladder is made by two different and separable parts. One is the rubber bladder of which the main feature lies in an original and well developed process that allows the construction in a **single piece**. The second part is the gas valve assembly that is seal connected on the bladder mechanically. This unique method allows to seal connect on the same bladder **different types**

of gas valve assembly (see pag. 37).

The two parts, bladder and gas valve assembly, can be ordered separately (for the assembling see pag. 41) so when is necessary the replacement of the bladder, it is possible to use again the gas valve assembly saving in this way money on the purchasing price of the spare bladder.

17.2 Technical and constructional features

- THE BLADDER**, used in the standard version of the accumulators of all the series offered by EPE, is made in butadiene-acrylonitrile rubber (NBR) with medium-high ACN content which we have denoted "**standard nitrile**" and distinguished with the letter **P**. The "**P**" bladder is above all suitable for use with mineral oils but gives also excellent results with many other liquids (see ch. 3.15 page 16). The operating temperature range is between -20 and $+85^{\circ}\text{C}$. For special requirements, temperatures exceeding the above limits, special liquids, etc. the bladder can be supplied in the following materials: Nitrile for low temperatures (**F**), Nitrile for hydrocarbons (**H**), Hydrogenated Nitrile (**K**), for foodstuffs (**A**), Butyl (**B**), Ethylene-propylene (**E**), Neoprene (**N**), Epichlorohydrin (**Y**).

N.B. Not all the bladders sizes are available in all the materials. Please consult our Technical Service Department before ordering.

- THE GAS VALVE** used in the EPE accumulators is made of phosphated carbon steel, in the following three versions:
 - S = STANDARD**, (fig. 1a). For capacities from 0,2 to 55 litres with inflating valve 5/8" UNF. This valve can be supplied with $\varnothing B$ and special inflation connections (see ch. 18.4).
 - ST = TRANSFER** (fig. 1b). Suitable for use with the accumulator connected to one or more additional nitrogen bottles. For capacities from 5 to 55 litres.
 - SL = LIQUID SEPARATOR** (fig. 1c). It is used when a liquid is also inside the bladder. For capacities from 0,2 to 55 litres.

- UPON REQUEST**, all the valves can be supplied with chemical nickel coating 25 μm . (other thickness to be specified) or in stainless steel.

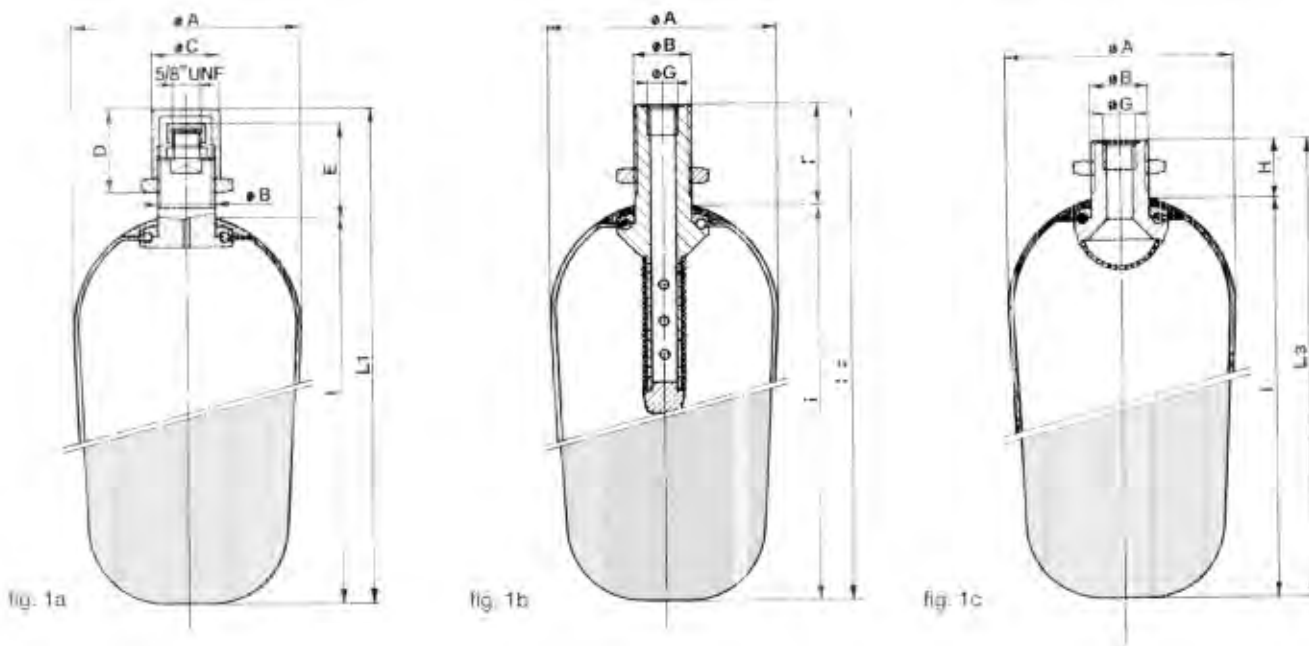

17.3 Bladder dimensions and spare codes for standard valves

Nominal capacities (Litres)	Bladder dimensions with valves fig. 1a - 1b - 1c												Bladd. weight kg	Gas valve assembly												
	$\varnothing A$	$\varnothing B$	$\varnothing C$	$\varnothing G$ ISO 228	D	E	F	H	I	L ₁	L ₂	L ₃		fig. 1a code No.	fig. 1a weight kg	fig. 1b code No.	fig. 1b weight kg	fig. 1c code No.	fig. 1c weight kg							
0,2	38	5/8" UNF	20	1/8" BSP	-	25	-	23	155	180	-	178	0,03	2002	0,1	-	-	2003	-							
0,7	75	M22x1,5 (Spec. $\varnothing B$ s. section 18.4)	25	1/4" BSP	47	51	36	28	126	182	-	154	0,07	2021	-	-	2027-1	0,27								
1	148								204	184	176	0,13	2022	0,3	2026	0,55	2027	0,18								
1,5	198								254	234	226	0,17														
2,5	325								381	361	353	0,30														
3	146								M50x1,5 (Spec. $\varnothing B$ s. section 18.4)	55	1" BSP	60	63	72	43	374	430	410	402	0,36	2042	0,42	2043	1,1	2048	0,33
4																215	272	252	247	0,33						
5	284															341	321	316	0,43	2062	1,7	2065	2,6	2073	1,1	
10	315															390	387	358	0,96							
12	400															475	472	443	1,08							
15	450															525	522	493	1,29							
20	583	658	655	626	1,79																					
25	735	810	807	778	2,22																					
35	1080	1155	1152	1123	3,28																					
55	1535	1610	1607	1578	4,59	2066	3,1	2067								3,6										

All dimensions in mm

Subject to change

17.4 Special gas valve

EPE bladders, in addition to their use in EPE accumulators, are perfectly interchangeable with many others brands available in the market.

In order to do that, gas valves (see below) are available with non-standard stem diameters ($\varnothing B$) and charge-connections.

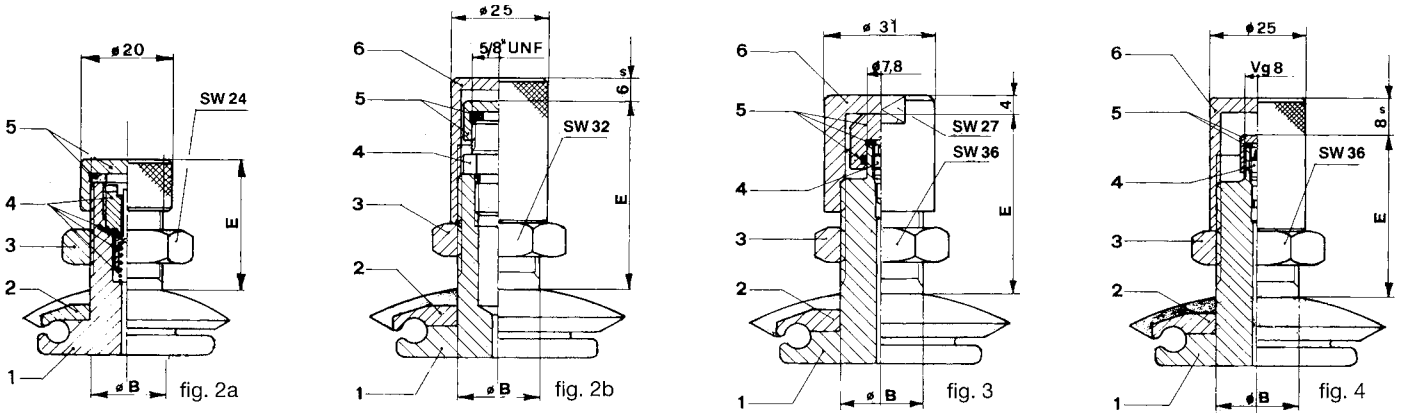

17.4.1 Dimensions and spare codes for special valves

Nominal capacities (litres)	Fig.	Bladder with valve code	Dimensions		Weight Kg	1) Spare order codes						
			$\varnothing B$	E		2) Gas valve assembly	Item 1 valve body	2) Item 2 washer	Item 3 locknut	Item 4 fill valve	Item 5 valve cap	Item 6 protect. cap
0,7 - 1 - 1,5 2,5 - 3	2a	S...2	5/8" UNF	26	0,15	2015	10110	10105	10023	2070	10337	-
	3	S...3	7/8" UNF	46	0,38	2019	10118	10106	10108	2069	10201	10200
	4	S...4			0,3	2020	10119				10134	10135
4 - 5	2a	S...2	5/8" UNF	30	0,27	2041	10255	10257	10023	2070	10337	-
	3	S...3	7/8" UNF	49	0,48	2045	10258	10205	10108	2069	10201	10200
	4	S...4			0,4	2046	10259				10134	10135
10 - 12 - 15 20 - 25 - 35 55	2b	S...2	M22x1,5	57	0,75	2061	10332	10331	10109	2072	10337	10103
	3	S...3	7/8" UNF	52	0,83	2084	10329		10108	2069	10201	10200
	4	S...4			0,75	2085	10330				10134	10135

1) The code denotes components made in carbon steel and washer coated in standard nitrile rubber. For different executions, add the letter N for nickel plated steel and the letter X for stainless steel to the code number.

2) If the washer is coated with an elastomer different from the standard nitrile, the code number should be followed by both the letter denoting the steel and the letter denoting the elastomer.

17.5 Identification code

The letter sequence denoting the bladders is very simple and follows the first part code of EPE accumulator (the type without the letter A, size, bladder material), to which is added **0** when the valve is not required and **1** when the bladder has to be completed with valve (fig. 1a-1b-1c).

For bladders used as a replacement in another brand of accumulator, in addition to the size and the material of the bladder, should

be indicated also the exact type of valve. The valve can be selected from either the standard types (fig. 1a/1b/1c), and denoted by 1, or from the special valves, respectively denoted by 2 (fig. 2a-2b), 3 (fig. 3), 4 (fig. 4), 5 (see page 22) and 6 for other types to be specified. When uncertain, the best way is to indicate also the type and brand of the accumulator. The example given is of a standard version bladder, for a 25 litres accumulator, in Nitrile, complete with $\varnothing B$ valve = M50x1,5 in phosphated C40 steel.

S
25
P
1
-

Bladder Type	Nominal capacities (Litres)	1) Bladder material	Gas valve	Gas valve material
S = Standard (fig. 1a) ST = Transfer (fig. 1b) SL = Liquid separator (fig. 1c)	0,2 - 0,7 - 1 1,5 - 2,5 - 3 4 - 5 - 10 12 - 15 - 20 25 - 35 - 55	P = Nitrile standard F = Nitrile for low temp. H = Nitrile for hydrocarbons K = Hydrogenated nitrile A = Nitrile for food-stuffs B = Butyl E = Ethylene-propylene N = Chloroprene (Neoprene) Y = Epichloridrin	0 = without valve 1 = with valve: standard $\varnothing B$ (fig. 1a, 1b, 1c) 2 = with valve: special $\varnothing B$ (fig. 2a, 2b) 3 = with valve: special $\varnothing B$ and filling connection (fig. 3) 4 = with valve: special $\varnothing B$ and filling connection (fig. 4) 5 = with valve for ASME U.S. (see page 22) 6 = others (on request)	- = Phosphated carbon steel N = Nickel coated carbon steel, thick 25 μm X = Stainless steel AISI 316

1) Features and compatibility see page 16

Subject to change

18.1 General

Accumulator stations are used when the flow rate or volumes required exceed the capacity of one single accumulator available from our range. These stations are assembled in a single line of 2 up to 5 accumulators (fig. A) or a double line of up to 8-10 accumulators (fig. B). The stations can also be used for the installation of piston accumulators connected to additional nitrogen bottles.

18.2 Version with welded manifold

A welded steel framework, made of welded steel and painted with a coat of rust inhibitor, supports the accumulators. According to their intended number and overall dimensions, they can be positioned in a single (fig. A) or double row (fig. B). Each accumulator leans on a flexible ring, is fastened with two clamps and has a connection block mounted (series **B10/20** or more often, series **BS25/32**). A **delivery manifold** consisting of a central pipe to which several branch pipes have been welded for connection to the relevant blocks (dimensions to be defined according to the flow rate and working pressure). Its two ends are female threaded ISO 228 or, on request, flanged. One of the two ends is closed off by a plug or blind flange. The same thing is applied also to the manifold which connects the discharges of the single blocks. On request a pressure gauge or a pressure switch can be installed for controlling the delivery pressure and a basin for collecting the oil. The double station can also be used for the installation of **transfer accumulators** connected to the **additional nitrogen bottles** mounted in parallel to the same. Various other versions can be supplied so it is advisable to contact our technical department in order to make the best choice.

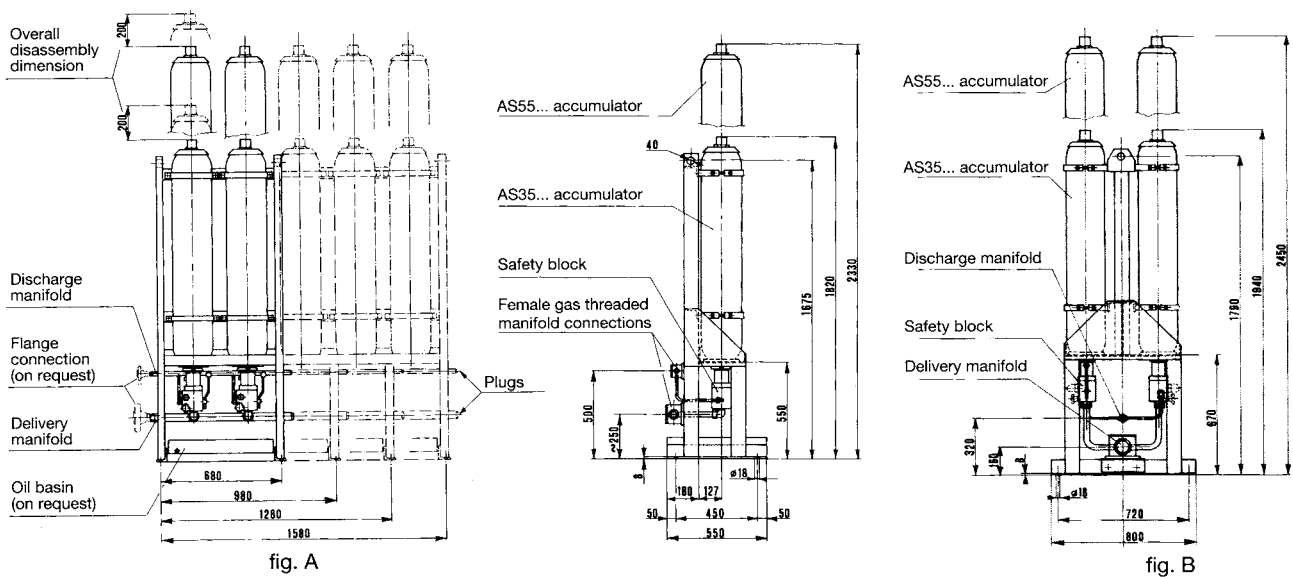

18.3 Version with block

This version involves the assembly of accumulators on a block acting as support and delivery and discharge manifold. In the most complete version (fig. D) each accumulator is isolated using the series BS25 or BS32 safety block on which all the accessories indicated on pages 30/31 can be mounted. The discharge of each accumulator, through the block, is obtained in the same delivery manifold.

18.4 Designation



Type	No. of accumulator	Accumulator type	Capacity	Drawing
Accumulator station	No. of accumulators installed	S = bladder P = piston F = other	Accumulator size	Drawing no.

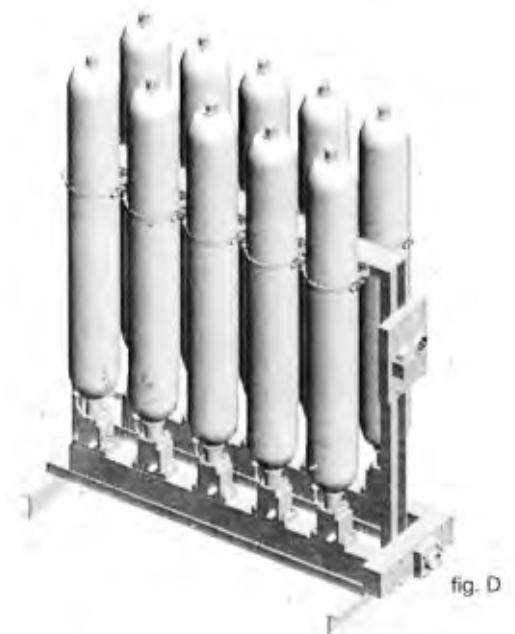

19.1 General

All EPE accumulators are carefully inspected and tested at the factory and are exactly as designated by **the code** printed on the name plate fixed on gas valve side of each accumulator.

On the name plate are printed also the following data:

- The max working pressure PS expressed in bar;
- Temperatures TS, minimum and maximum, allowable (°C);
- The pre-charge value P₀ expressed in bar (glued label);
- Fabrication number of the accumulator;
- EC mark along with the number of the Notified Body (only when provided by the regulations);
- Fabrication date: month/year;
- Group of Fluids and some essential regulations for the safety;
- Name, logo, Country and phone number of the manufacturer.

ATTENTION: The max working pressure marked on the accumulator must be ≥ than the calibrated pressure of the relief valve mounted in the hydraulic circuit.

Before undertaking any work (repairs, replacement, etc.) on a hydraulic circuit mounting an accumulator, **it is mandatory to release completely the liquid pressure.**

Test certificates, if required, are supplied with the accumulator or forwarded by mail or in another way.

19.2 Preliminary checking

Upon receipt check:

- That there has been no damage in transit.
- The identification code indicated on the name plate is as ordered.

Before installation is also important to ensure that: the gas pressure corresponds to the required value.

The initial gas pressure must be selected to meet the service requirement.

In general the design values are as follows:

P₀ = 0,9 P₁ (energy reserve, line shock absorber, etc.)

P₀ = 0,6 - 0,7 P₁ (pulsation damper).

Gas precharge pressure is of a crucial importance for the correct operation of the accumulator and for the durability of the bladder.

The gas pressure, when the accumulator is supplied precharged, **is related to a temperature of 20°C.**

In the case of accumulators supplied without pre-loading pressure, or after repair work, it is necessary to perform the inflation with nitrogen; must be also performed the check of the system using the equipment type PC... following the procedure provided on ch. 20 page 40.

19.3 Installation

To achieve a high degree of efficiency, the accumulator should be fitted **as close as possible** to the installation that it serves.

POSITION is possible from vertical one (gas valve on top) to the horizontal one.

It is recommended to leave:

- space necessary for testing and filling equipment.
- manufacturer name plate stating initial pressure visible.
- access to vent screw unobstructed.

Correct **FASTENING** is given using clamps and brackets arranged as per figure.

Is absolutely forbidden welding of supports or machining on the accumulator shell.

THE CONNECTION to the fluid valve, directly or through an adapter or a flange, have to be done with the means of a spanner so that the **fluid valve can be not turned independently** of the accumulator shell.

- A **non-return valve** has to be fitted between pump and accumulator.
- To be sure that the pressure limiter valve of the circuit is directly connected with the accumulator and calibrated at a value lower than the working pressure marked on the name plate of the accumulator.
- Is often recommended foreseen a shut-off and discharge valve in order to isolate the accumulator (for periodic checks or repairs) also during the system operation.

All these functions are obtained with the application of connection block **EPE series B** or **BS** limiting encumbering joints (see pages 28 ÷ 31).

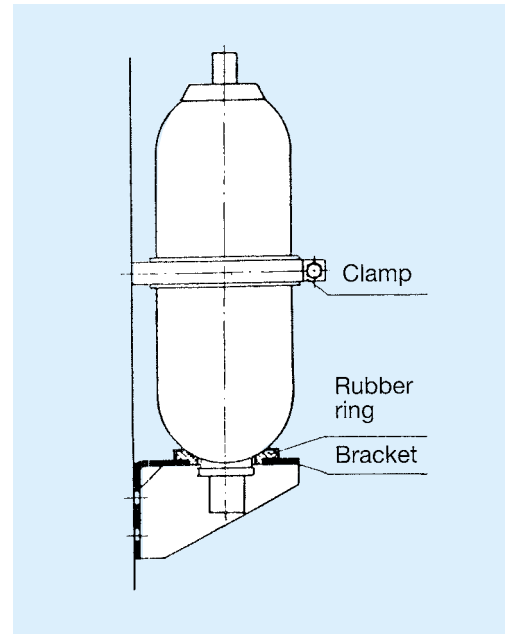

19.4 Initial operating

In order to avoid risk of damage to the bladder, make sure that the **accumulator has been precharged.**

Then place the circuit under pressure, check the connections for leaks and proceed to bleed the air.

Then **tighten the gas valve locknut carefully.**

Start up definitively the hydraulic system.

The accumulator completely works automatically.

19.5 Periodic checks

It has to be ensured the **maintenance** of gas pre-charge.

The first check have to be done **within the first week** after the start up of the system.

If has not been noticed any leakage, the following check should be carried out **after 3 months** and afterwards **every 6 months.**

For heavy uses the check have to be carried out monthly.

20.1 General

In order to guarantee the correct functioning of the accumulator, it is necessary to keep constant the gas precharge pressure. Therefore periodically the gas precharge pressure must be checked with **EPE pre-loading equipment PC250S...**

The same equipment have to be used for re-inflating the bladder (after a repair, for a changing of use, etc..) connecting with the proper hose to a dry nitrogen bottle provided with a pressure reducer so that the nitrogen goes into the bladder of the accumulator very slowly in order to avoid bursts of the bladder itself. **IN ANY CASE MUST BE USED ONLY NITROGEN, NEVER AIR OR OXYGEN.**

20.2 Pressure check

This is a simple operation and the correct procedure is as follows:

- **Isolate** the accumulator from the system and reduce the liquid **pressure to zero.**
- Remove the protective and sealing caps from the gas valve and from the gas-fill valve.
- Before mounting the **PC250** equipment, ensure that knob **A is unscrewed**, that bleed valve **B is closed** and that non-return valve **C is screwed tight.**
- Connect the unit to the gas-fill valve by means of the knurled nut **D.**
- Screw valve **A** to the point where pressure is registered.

If the value **correspond** to the one established, remove the equipment, unscrewing the nut **D**, taking care before of:

- **Unscrew** the knob **A**
- **Open** the bleed **B**

20.3 Pressure reduction

If the pre-charge value is **higher** than the one required, has to be reduced opening slowly the bleed valve **B** till the reaching of the correct value required.

It is advisable to **discharge slowly** and to check again after few minutes from the discharge operation. After that it is possible to remove the PC250 equipment as above described.

20.4 Increase or reset precharge pressure

If the pre-charge is lower than the established value (or if it is necessary the re-inflating of the bladder after a repair) proceed as follow (the pre-loading unit **is already set** as indicated at ch. 20.2):

- Fit the nipple to the nitrogen bottle or to the pressure reducer.
- Fit the hose extremity to the nipple.
- Connect the other hose extremity to the check-coupling **C** after taking off its cap.
- Open **slowly** the shut-off valve or the pressure reducer of the nitrogen bottle and keep it open till the reaching of a pressure slightly higher than the required value, then **close** the shut-off valve.
- **Unscrew** the knob **A** and **decompress** the equipment through the bleed valve **B.**
- Disconnect the micro-hose from the check-coupling **C.**
- **Close** the bleed valve, replace the **cap** on the check-coupling **C** and wait few minutes for the pressure stabilisation.
- Screw the valve **A** till the pressure can be read. This should be slightly higher than the required value.
- Adjust, through the bleed valve, the pre-charge value and proceed with the removal of the equipment as previously described.
- Use soap water test for checking leakages from the gas-fill valve of the accumulator.
- Replace the gas-fill valve cover and the external protection cap.

The accumulator now is ready for use.

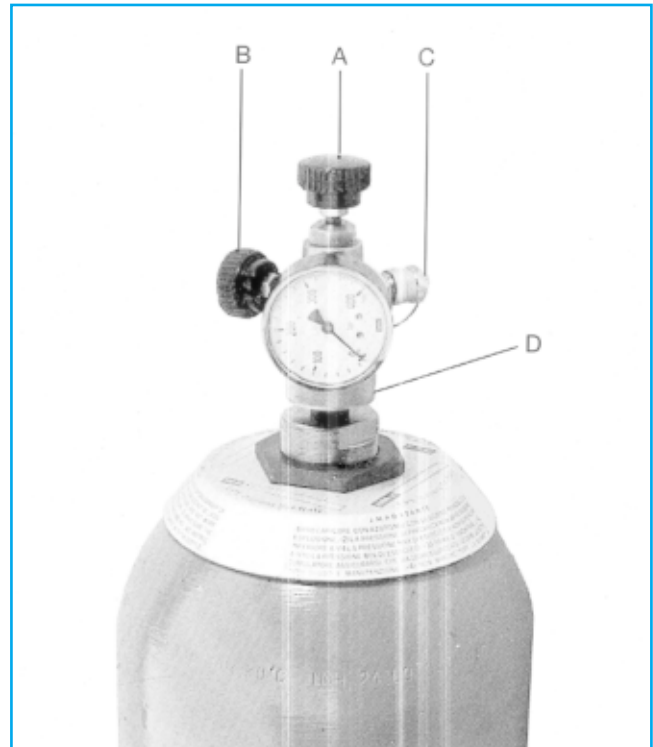

IT IS NECESSARY TO USE A PRESSURE REDUCER IN ORDER TO INFLATE THE ACCUMULATORS (E.G. LOW PRESSURE SERIES) THAT HAVE A MAX WORKING PRESSURE LOWER THAN THE PRESSURE OF THE NITROGEN BOTTLE.

N.B.: The pre-loading unit PC250 is supplied with one manometer 0 ÷ 250 bar. Of course in order to check pressures higher than 250 bar **it is necessary** to be equipped with a manometer with a suitable full-scale.

Also for low pressures the accuracy of measuring is higher using a suitable manometer: e.g. with pressures ≤ 30 bar it is advisable a full-scale of 60 bar.

21.1 General

If the accumulator has to be stripped for any reason, the following procedure **must be followed in the sequence shown**.

Before removing accumulators for servicing, the gas **pressure must be reduced to zero**. As the liquid connections for the high pressure and low pressure ranges differ (fig. A and B), the procedures will be slightly different. While the bladder is exactly the same in the two types.

21.2 Dismantling of the accumulator

First, the accumulator must be cut off and discharged from the liquid pressure and removed from the hydraulic circuit, after that place the accumulator horizontally in a vice then proceed, for both the types, as follows:

- **Remove** the protection **cap** of gas valve.
- **Discharge completely the gas** from the bladder by means of the PC250 unit.
- **Dismantle** the gas-fill valve.

Only at this point the liquid connection can be dismantled.



LOW PRESSURE RANGE

HIGH PRESSURE RANGE



fig. A

fig. B



1



4



2



5



3



6

HIGH PRESSURE RANGE

- 1) Remove the bleed screw.
- 2) Remove the ring nut and the spacer ring.
- 3) Push the fluid port body into the vessel and remove gaskets.
- 4) Remove by bending the rubber coated retaining ring.
- 5) Remove the fluid port body.
- 6) Remove the nut that tightens the gas valve and the name plate.
- 7) Remove the bladder from the liquid side by slightly twisting.



7

LOW PRESSURE RANGE

The opening of the fluid side is released removing:

- The bleed screw
- The spring ring
- The anti-extrusion plate

At this point proceed as for the high pressure range removing the nut that tightens the gas valve and the name plate and, finally, removing the bladder with the gas valve from the liquid side.

21.3 Cleaning and inspection

Clean carefully all the components including the bladder and the inside of the accumulator body.

Mainly check that:

- THE BLADDER is not **worn**, **damaged** or **with bulges** due to not suitable liquids.

- THE POPPET VALVE slides freely, that the **spring** is not damaged and that the **selflocking nut** fixing the brake bushing is tighten carefully.

- GASKETS AND SEALS are not worn.

- THE INTERIOR SURFACE of accumulator body doesn't have cracks or signs of failure.

REPLACE ALL SUSPECT AND WORN PARTS. THE BLADDER CANNOT BE REPAIRED.

21.4 Bladder - gas valve assembly

If the bladder have to be replaced and the gas valve is in good condition, it is possible to fit the new bladder to the old gas valve (or viceversa) taking care to ensure that the edge of the mouth piece makes a **perfect fit** with the valve seat. Then the valve is put into place, by means of hands, pressing on the rubber coated washer until it is no longer possible to remove it unless force is used. The bladder can now be inserted into the accumulator.



21.5 Assembling of accumulator

Ensured that all components are in good conditions and **perfectly clean**, reassemble in the following order:



HIGH PRESSURE RANGE

- 1) Insert the bladder (for large sizes use a threaded tube M 12 x 1,5).
- 2) Mount the name plate and the nut of the gas valve body.
- 3) Tighten the nut holding the gas valve stem with a spanner.
- 4) Insert the liquid valve and then the rubber coated retaining ring.
- 5) Locate the valve on to the support ring fit gaskets and spacer ring.
- 6) Tighten the ring nut making sure the assembly is centrally located.
- 7) Fit the bleed screw with gasket. Pour a small quantity of liquid into the accumulator in order to lubricate the inside.

Finally mount the gas-fill valve, precharge the accumulator according to instructions of section 20.4 and tighten again the gas valve nut.



LOW PRESSURE RANGE

Proceed as for the high pressure range introducing the bladder and fitting it with the proper nut.

Then insert the anti-extrusion plate into the liquid connection, fastened by the spring ring (ensure perfect location on the seat).

Finally fill according to instructions section 16.4 and **tighten again the gas valve nut**.

The accumulator can now be installed in the system (ref. section 19.3 and 19.4).

- (AUS) AUSTRALIA**
STAUFF CORPORATION PTY LTD
 24-26 Doyle Avenue
 P.O. BOX 227 Unanderra NSW 2526
 Tel.: 0061 2 42711877
 Fax: 0061 2 42718432
 E-mail: stauff@stauff.com.au
-
- (B) BELGIUM + LUXEMBOURG**
EMAC S.A.
 Industrialaan 1, Zone Maalbeek
 1702 Groot-Bijgarden
 Tel.: 0032 2 4810211
 Fax: 0032 2 4810301
 E-mail: bpa@emac.be
- (L)**
-
- (BY) BIELORUSSIA**
HYDRO-CONNECT ODO
 Kalinowski st. 53/3
 220103 Minsk
 Tel.: 00375 17 2839420
 Fax: 00375 17 2839767
 E-mail: info@hydro-connect.com
-
- (BR) BRAZIL**
HT-HIDRAUTRONICA ICEI LTDA
 Rua: E. Volpini, 45 - Sao J. Batista
 CEP: 31515-190 Belo Horizonte - Minas Gerais
 Tel.: 0055 31 34941657
 Fax: 0055 31 34941831
 E-mail: gsf@hidrautronica.com.br
-
- (CO) COLOMBIA**
HYDRÁULICA Y NEUMÁTICA LTDA
 Cra. 50FF No.7 Sur-17
 Apartado Aereo No.49204 Medellin
 Tel.: 0057 4 3621600
 Fax: 0057 4 3620969
 E-mail: turbinas@hidraulicayneumatica.com.co
-
- (SK) SLOVAKIA REPUBLIC + HUNGARY**
HYDRAULIK INNOVATION GMBH
 Oberbreitenstrasse, 17a
 4050 Traun/Linz
 Tel.: 0043 7229 516660
 Fax: 0043 7229 5166614
 E-mail: Hydrinno@aon.at
-
- (RC) CHINA**
STAUFF (SHANGAI) INTERNATIONAL TRADING CO. LTD
 Shangdian Mansion,
 331 Binzhou Rd., Pudong, Shanghai 200126
 Tel.: 0086 21 58456818
 Fax: 0086 21 58456680
 E-mail: stauffsh@public.sta.net.cn
-
- (DK) DENMARK**
PMC TECHNOLOGY A/S
 Klausdalsbrovej, 11 - 2860 Soborg
 Tel.: 0045 70 212121
 Fax: 0045 70 212122
 E-mail: info@pmctechnology.dk
-
- (F) FRANCE**
ABDON S.A.R.L.
 11, Rue Louis Blanc - 13400 Aubagne
 Tel.: 0033 4 42842046
 Fax: 0033 4 42842072
 E-mail: christian.abdon@wanadoo.fr
-
- (GB) GREAT BRITAIN**
EPE (U.K.) LTD
 16 Manor Industrial Estate
 Flint, Flintshire, CH6 5UY
 Tel.: 0044 1352 730720
 Fax: 0044 1352 730820
 E-mail: epe.uk@btconnect.com
-
- (GR) GREECE**
HYDRAULIC TECH. O.E. SARAFIANOS BROSS
 Monastiriou 100 - 54627 Thessaloniki
 Tel.: 0030 2310 525523
 Fax: 0030 2310 516531
 E-mail: isip@otenet.gr
-
- (ATHENS HYDRODYNAMIC S.A.)**
 56, Athinion Avenue - 10441 Athens
 Tel.: 0030 210 5221155
 Fax: 0030 210 5221485
 E-mail: hydrodyn@otenet.gr
-
- (NL) HOLLAND**
EPE GOLDMAN B.V.
 Admiraal Trompstraat, 4
 3115 HH Schiedam
 Tel.: 0031 10 4269999
 Fax: 0031 10 4269080
 E-mail: sales@epe-goldman.com
-
- (IND) INDIA**
EPE PROCESS FILTERS & ACCUMULATORS PVT. LTD.
 59-A, C.I.E., Gandhinagar, Balanagar
 Hyderabad 500 037
 Tel.: 0091 40 23085750
 Fax: 0091 40 23086781
 E-mail: business@epe-india.com
-
- (IL) ISRAEL**
OZ HYDRAULICS & PNEUMATICS LTD
 No.5 Horkanus, North Ind. Area
 71293 Lod
 Tel.: 00972 8 9777640
 Fax: 00972 8 9777679
 E-mail: oz-hydraulics@oz-hyd.co.il
-
- (ROK) KOREA**
LEE HWA SPECIAL TRADING CO., LTD
 RA 1323 Chungang Complex, Guro-Dong
 Guro-Ku, Seoul 152-721
 Tel.: 0082 2 26165511
 Fax: 0082 2 26167545
 E-mail: KEG9463@chollian.net
-
- (MAL) MALAYSIA**
POWERMATICS HYDRAULICS & ENGINEERING (M) SDN. BHD
 No.7 Lengku Keluli 2, Kaw Perindustrian Bukit
 Raja, 41050 Klang, Selangor
 Tel.: 0060 3 33448000
 Fax: 0060 3 33446000
 E-mail: sales@powermatics.com
-
- (MEX) MEXICO**
ALFA HIDRAULICA S.A.
 A. Gonzales 244 col. Sta M. Aztahuacan
 C.P. 09570 - D.F.
 Tel.: 0052 555 6923077
 Fax: 0052 555 6923495
 E-mail: alfahi@prodigy.net.mx
-
- (MA) MOROCCO**
GT MAROC S.A.R.L.
 47, Zankat Marmoucha
 La Villette - 20300 Casablanca
 Tel.: 00212 2 2623667
 Fax: 00212 2 2623811
-
- (N) NORWAY**
SERVI MOTION CONTROL AS
 Haugenvæien, 2 - 1402 Ski
 Tel.: 0047 64 979797
 Fax: 0047 64 979899
 E-mail: servi@servi.no
-
- (PL) POLAND**
F.E.H. FABRIKA ELEMENTOW HYDRAULIKI S.A.
 Ul. Wojska Polskiego, 29
 34100 Wadowice
 Tel.: 0048 33 8234441
 Fax: 0048 33 8233840
 E-mail: ponar@ponar-wadowice.pl
-
- (SGP) SINGAPORE**
PH HYDRAULICS & ENGINEERING PTE. LTD
 27 Gul Lane, Jurong
 629421 Singapore
 Tel.: 0065 6861 2000
 Fax: 0065 6861 5000
 E-mail: phhyd@singnet.com.sg
-
- (SLO) SLOVENIAN**
LE-TEHNIKA, d.o.o.
 Suceva ulika, 27
 4000 Kranj
 Tel.: 0086 4 2042121
 Fax: 0086 4 2042122
 E-mail: hydraulic@le-tehnika.si
-
- KLADIVAR ZIRI**
 Industrijska c. 2, p.p. 14
 4226 Ziri
 Tel.: 00386 4 5159100
 Fax: 00386 4 5159130
 E-mail: kladivar@kladivar.si
-
- (ZA) SOUTH AFRICA**
GOLDQUEST INTERNATIONAL HYDRAULICS LTD
 P.O. BOX 4299 - 26 Barney Road
 2094 Benrose - Johannesburg
 Tel.: 0027 11 6142004
 Fax: 0027 11 6142033
 E-mail: admin@goldquest.co.za
-
- (E) SPAIN**
TECONASA SUMINISTROS S.A.
 Avda. Carlos Marx, 80
 Poligono Ind. Horno de Alcedo - 46026 Valencia
 Tel.: 0034 96 3182010
 Fax: 0034 96 3182275
 E-mail: teconasa@teconasa.com
-
- (CH) SWITZERLAND**
HINEL AG
 Industriestrasse, 2 - 3178 Bösingen
 Tel.: 0041 31 7478881
 Fax: 0041 31 7479827
 E-mail: Hinel@datacomm.ch
-
- (ROC) TAIWAN**
LIMIT TEIN INDUSTRIAL CO., LTD
 3F-7, No. 4, Lane 609, Sec. 5 - Chung Shin Rd.
 Sanchung City, Taipei Hsien, 241, R.O.C.
 Tel.: 00886 2 29995022
 Fax: 00886 2 29995055
 E-mail: limitein@ms33.hinet.net
-
- (T) THAILAND**
PNEUMAX CO., LTD
 104/21 Moo 8, Chaloe Phrakiat R.9 Rd.
 Pravet, Bangkok 10250
 Tel.: 0066 2 7268000
 Fax: 0066 2 7268260
 E-mail: import@pneumax.co.th
-
- (TR) TURKEY**
MERT TEKNİK FABRIKA MALZEMELERİ
 Ticaret ve Sanayi A.S.
 Tersane Cad. 43, Karakoy - 80000 Istanbul
 Tel.: 0090 212 2528435
 Fax: 0090 212 2456369
 E-mail: info@mert.com