



Accessories

The solutions for all your needs





A complete range of accessories

Sunfab develops, produces and sells piston pumps and motors for operating demanding hydraulic equipment in mobile applications. We also supply a unique range of accessories, which you will find in the following pages.

Sunfab's accessories are a unique range of components designed to meet a bodybuilder's need of basic hydraulic installations.

The vehicle's basic hydraulic installation requires a power take off, pump and hydraulic connections. Not to mention suspension fittings and perhaps adapter flanges with intermediate shaft assembly and the possibility of a distributing gearbox.

Sunfab's vast experience and close co-operation with vehicle bodybuilders forms the basis of our selection of suitable accessories.

The accessories are tested and appraised to maintain the same high quality that characterizes Sunfab pumps and motors.



If the part number is followed by a symbol  this indicates that assembly fittings are supplied.

The symbol  refers to a page number with further details.



Content Overview

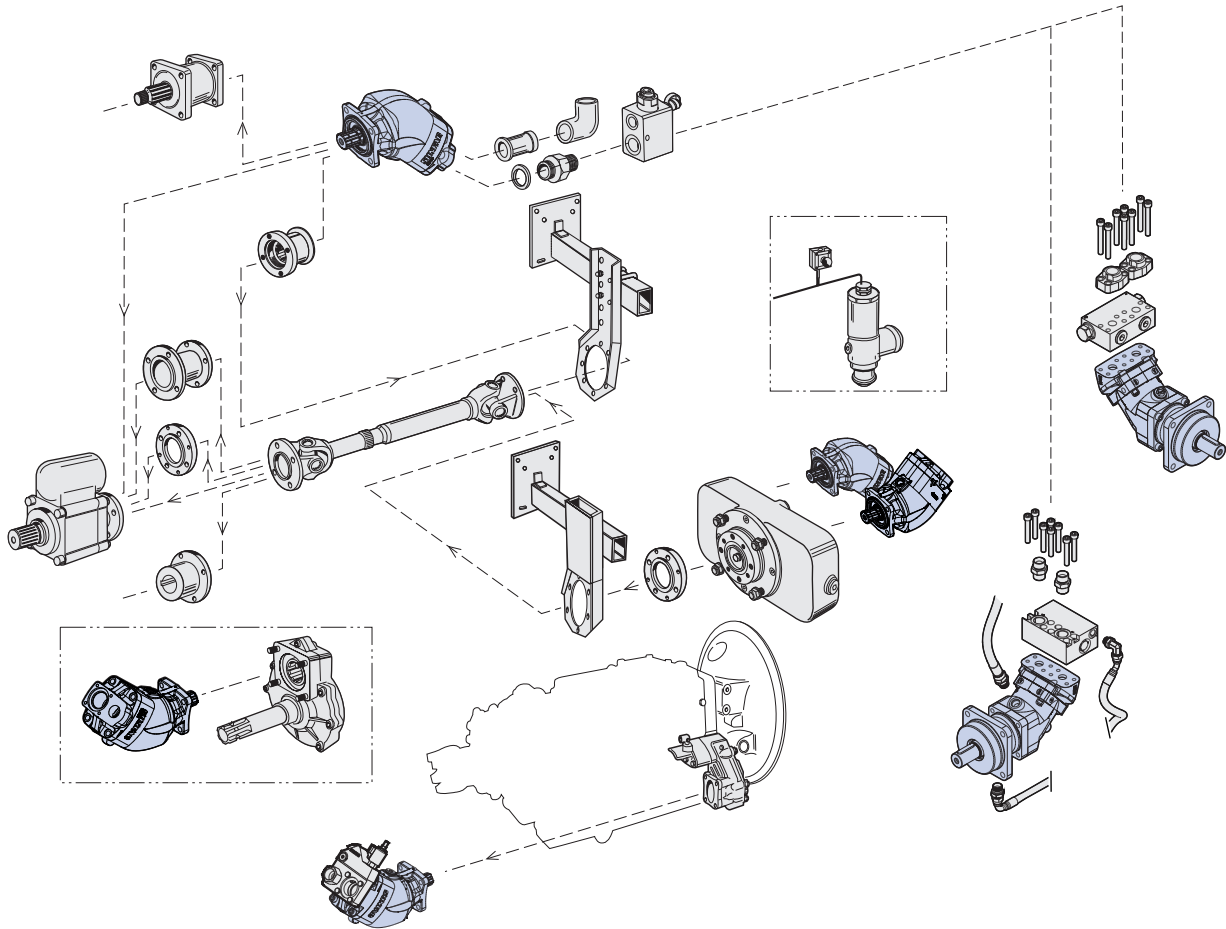

Connections

Suction Connections	1:1
Checkvalves/Pressure connections	1:2
SAE flanges kits	1:3
Check Valve	1:4
Adapter straight, 45°	1:5
Connection rubber 90°	1:6

Gearboxes

Tracpower Gearbox	2:1-2:2
Splitter Gearbox	2:3
Splitter Box	2:4

Suspensions

DIN 5462 (ZF)	3:1
SZ 118/154	3:2
Drive Shafts	3:3
Adapter flange - splitter gearbox	3:4
Adapter flanges	3:5-3:9

Splined drive flanges	3:10
Neutral Drive flanges	3:11
Drive flanges	3:12
Splined drive flanges SAE	3:13-3:14
Splined drive flanges 6 - SP/1 3/8"	3:15

Adapters

Drive-Flange & adapter for DIN power take off	4:1
Special adapter SCANIA	4:2
Distance Adapter Kit	4:3
Special adapter 6 - SP/1 3/8"	4:4
Adapter SAE	4:5-4:6
Adapter Uni - DIN	4:7

Valves Pump

By-Pass Valve	5:1
Pressure relief valve	5:2
Directional valve 3/2	5:3
High Pressure Filter LS	5:4
Shuttle Valve	5:5

Valves Motor

Anti-Cavitation valve	6:1
Flushing valve	6:2

Injector

7:1

Speed Sensor

8:1

Various

Gaskets	10:1
Stud kit	10:2
Diode Gate	10:3



Suction Connections Sauganschlüsse Suganslutningar

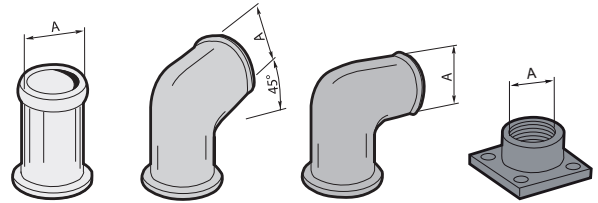
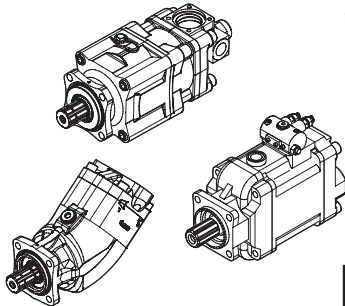

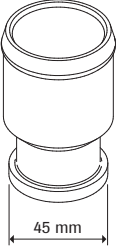
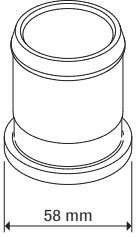
	A		max. l/min				
	mm	inch		0°	45°	90°	
SAP 012-064 SCP 012-064 SAPT 090 	32	1 1/4"	50	18245	—	—	—
	38	1 1/2"	65	18048	20100	18400	—
	42	1 5/8"	85	—	20136	—	—
	45	1 3/4"	110	—	20423	—	—
	50	2"	120	18047	20101	18401	—
	64	2 1/2"	165	—	20139	—	—
		G 1"	50	—	—	—	50403
SAP 084-108 SCP 084-108 SAPT 130 SCPD 56/26, 76/76 SLPD 20/20-64/32 SVH 062-130 	38	1 1/2"	65	18049	—	18402	—
	42	1 5/8"	85	—	20137	—	—
	45	1 3/4"	110	—	20424	—	—
	50	2"	120	17890	20102	18403	—
	64	2 1/2"	165	18603	20103	18394	—
	75	3"	260	18366	20274	—	—
		G 1 1/4"	80	—	—	—	50404

Given flows valid for mineral oil (10-1500 cSt) and maximum of 2 meter long suction line.

Die angegebenen Volumenströme beziehen sich auf Mineralöle (10-1500 cSt) und einer max. 2 Meter langen Saugleitung.

Angivna flöden gäller för mineralolja (10-1500 cSt) och max 2 meter lång sugledning.



Checkvalves
Pressure connections

Rückschlagventilen
Druckanschlüsse

Backventiler
Tryckanslutningar

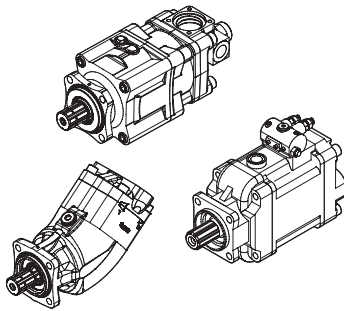
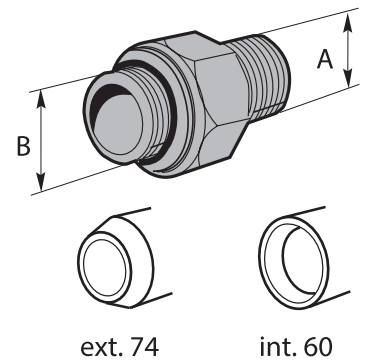
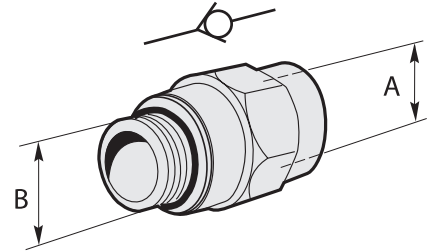

	max. l/min	A		B			
			Taper Kegel Kona		Taper Kegel Kona		
SAP 012-064	90	G $\frac{3}{4}$ "	-	G $\frac{3}{4}$ "	int. 60°		50296
SCP 012-064	160	G $\frac{3}{4}$ "	int. 60°	G1"	int. 60°		50297
SAPT 090							
SCPD 56/26, 76/76	90	G $\frac{3}{4}$ "	-	JIC 1 $\frac{1}{16}$ "	ext. 74°		
SLPD	90	G $\frac{3}{4}$ "	-	G $\frac{3}{4}$ "		91712	
SVH 062							
SAP 084-108 SCP 084-108 SAPT 130 SVH 092-130	160	G1"	-	G1"	int. 60°		50299
	160	G1"	-	JIC 1 $\frac{1}{16}$ "	ext. 74°		50300
	160	G1"	-	JIC 1 $\frac{5}{16}$ "	ext. 74°		50301
	90	G1"	-	G $\frac{3}{4}$ "	int. 60°		50302
	160	G1"	-	G1"			91713

3404GB-DE-SE1506 Rev 1.0





SAE flanges kit (includes 1 flange, 1 o-ring and 4 screws)

SAE Flanschen kit (enthält 1 flanch, 1 o-ring und 4 schrauben)

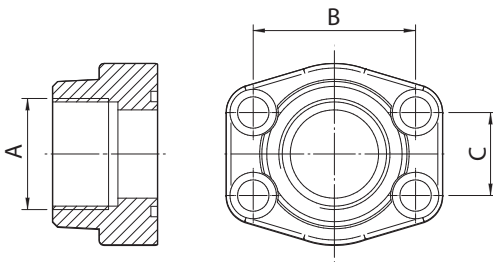
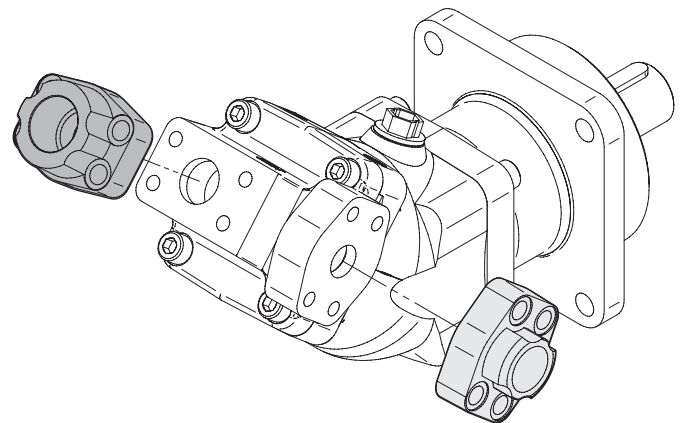
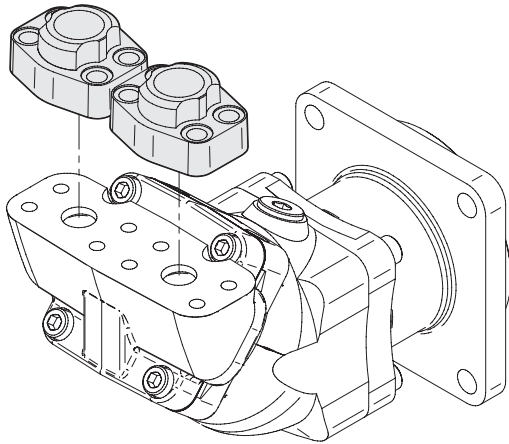
SAE flänssats (inkluderar 1 fläns, 1 o-ring och 4 skruvar)



CM ³ /rev	A	B	C	SCM Motor 				SCP ISO Pump 	
				ISO/M	ISO/UN	SAE/UN	SAE/M	SCP ISO	
				6000 Psi	6000 Psi	6000 Psi	6000 Psi	3000 Psi	6000 Psi
25 - 34	G 1/2"	40,49	18,24	50644			50644		50644
25 - 34	G 3/4"	47,63	22,23					50938	
40 - 64	G 3/4"	50,80	23,80	50512	50432	50432	50512		50512
40 - 64	G 1"	52,37	26,19					50435	
84 - 130	G 1"	57,15	27,76	50513	50431	50431	50513		50431
84 - 90	G 1 1/4"	58,72	30,18					50645	
84 - 130	G 1 1/4"	66,68	31,75	50939			50939		50939
108 - 130	G 1 1/2"	69,85	35,71					50940	

Check valve / counter pressure valve
 Rückschlag ventil/ gegendruckventil
 Backventil / mottrycksventil

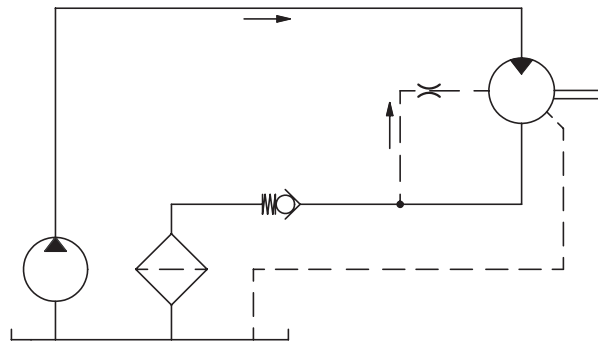
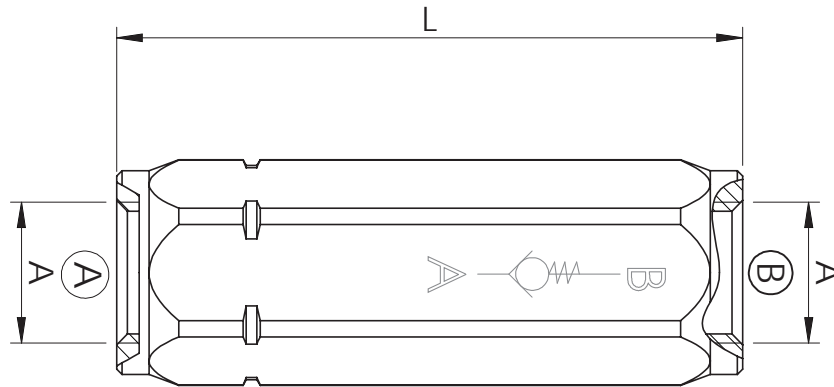





		Cracking pressure Öffnungsdruck Öppningstryck	l/min	L	Max pressure Max druck Max tryck	
SCM	3/4"	92368	0,5	150	83 mm	420 bar
		92370	4			
		92372	8			
	1"	92369	0,5	200	106 mm	420 bar
		92371	4			
		92373	8			
						Equipment Ausrüstung Utrustning

3446GB-DE-SE1709 Rev 1.0

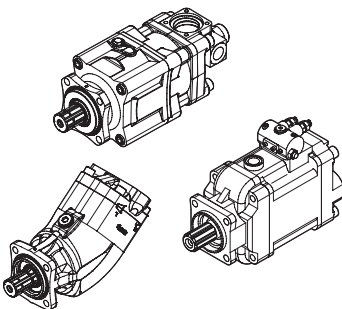
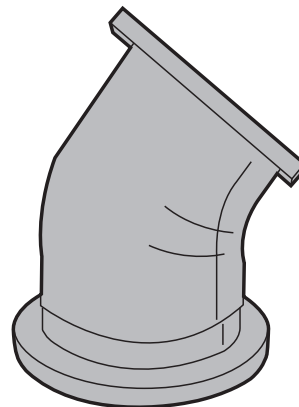
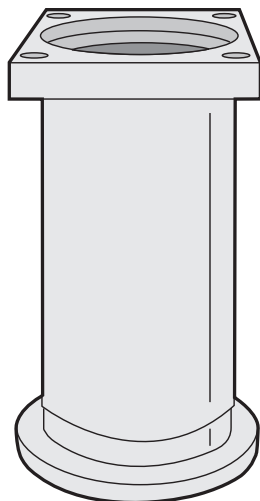
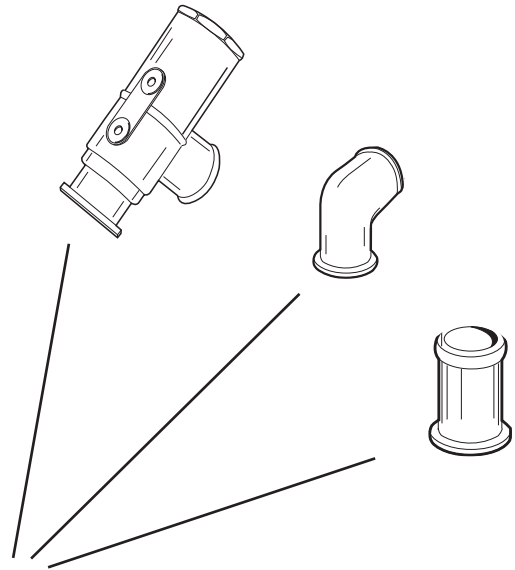

Adapter straight, 45°
 Adapter gerade, 45°
 Adapter rak, 45°



SAP 084-108, SAPT 130 SCP 084-130 SCPD 56/26, 76/76 SLPD, SVH	50944 	18273 	 Page 1:1
--	---	---	--

Connection rubber 90°
 Anschlüsse Gummi 90°
 Anslutning gummi 90°

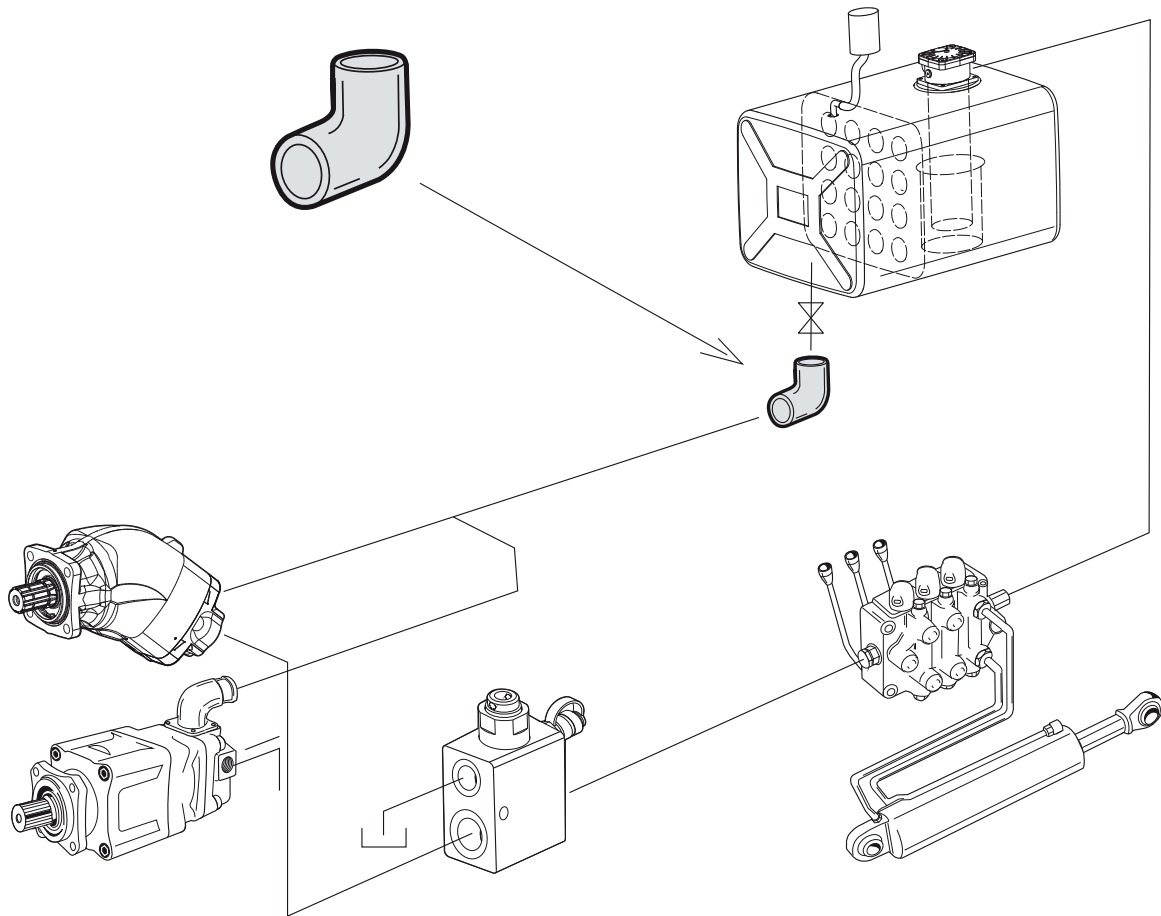

All pumps Alle Pumpen Alla pumpar	Ø 38 mm	65 l/min	17732	Equipment Ausrüstung Utrustning
	Ø 50 mm	120 l/min	17767	
	Ø 64 mm	160 l/min	18775	
	Ø 75 mm	260 l/min	18778	



TRACPOWER Gearbox
 TRACPOWER Zapfwellengetriebe
 TRACPOWER Tappväxel

DIN 5462

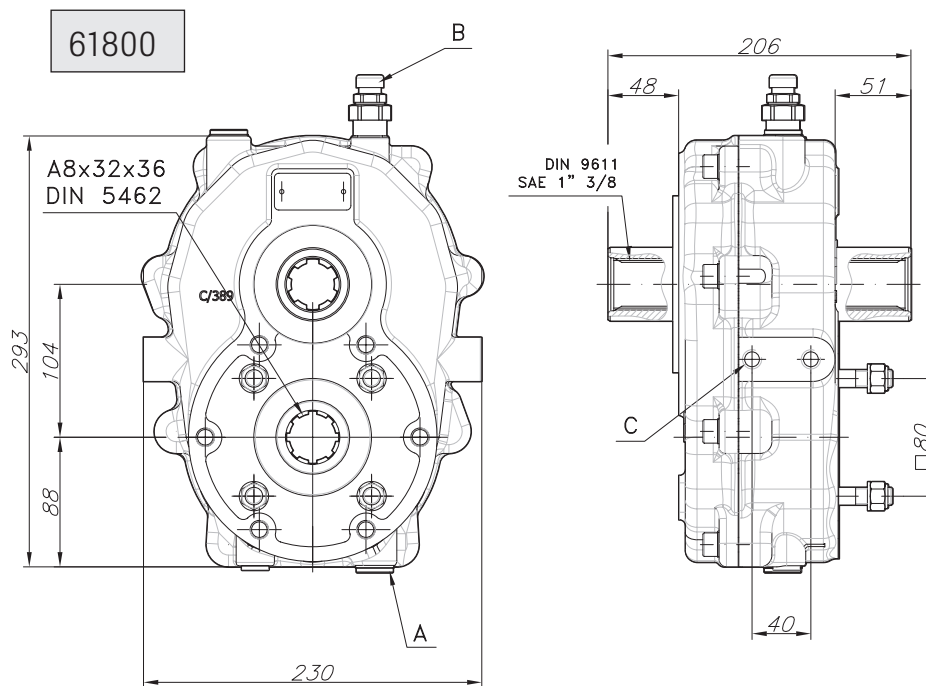

17814

Ratio
 Übersetzung
 Utväxling

Max. torque Nm / pump
 Max. Drehmoment Nm / Pumpe
 Max moment Nm / pump

	Ratio Übersetzung Utväxling	61800	17814	320	1 3/8" SAEJ1170
All Alle DIN 5462 (ZF) Alla	1:2.5				

For detailed information,
 see separate Datasheet on
 our [website](#).

Ausführliche Beschreibung:
 Siehe Datenblatt auf
 unserer [Website](#).

För detaljerad information se separat
 datablad på vår [hemsida](#).

3408GB-DE-SE1506 Rev 1.1



TRACPOWER Gearbox
 TRACPOWER Zapfwellengetriebe
 TRACPOWER Tappväxel

DIN 5462

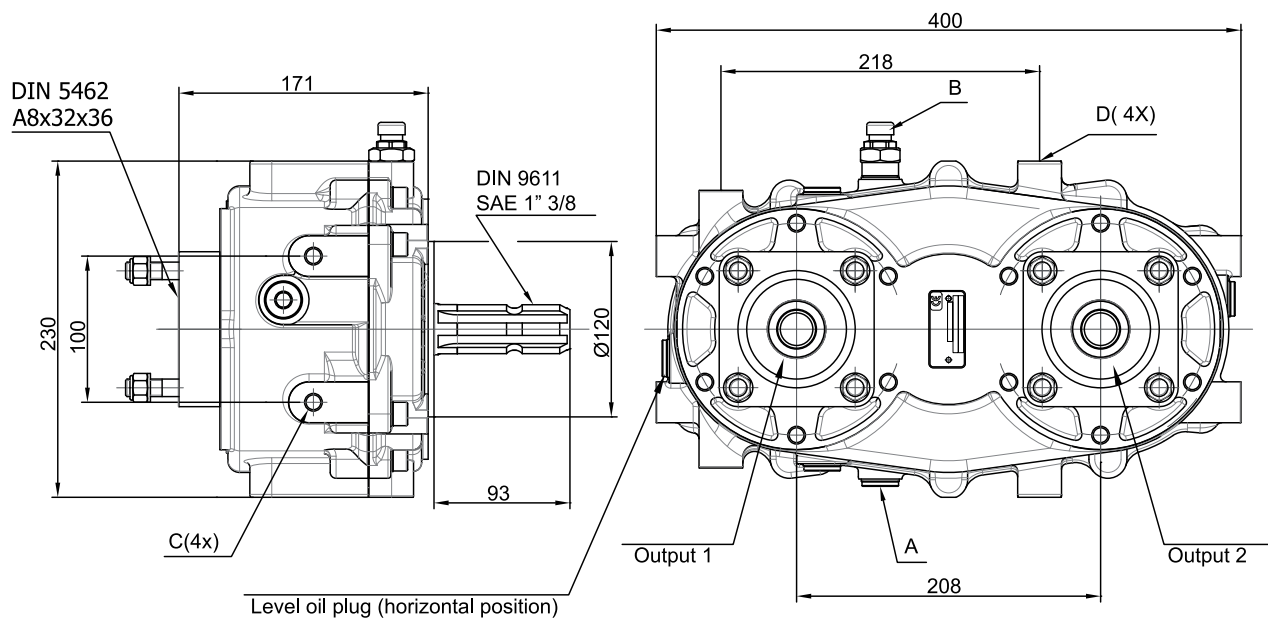

	Ratio Übersetzung Utväxling	61820	Max. torque Nm Max. Drehmoment Nm Max moment Nm	13/8" SAE J1170
All Alle DIN 5462 (ZF) Alla	1:2.5	61820	320	13/8" SAE J1170

For detailed information,
see separate Datasheet on
our [website](#).

Ausführliche Beschreibung:
Siehe Datenblatt auf
unserer [Website](#).

För detaljerad information se separat
datablad på vår [hemsida](#).

For additional configurations,
contact Sunfab.

Für weitere Konfigurationen
kontaktieren Sie bitte Sunfab



För ytterligare konfigurationer,
kontakta Sunfab.

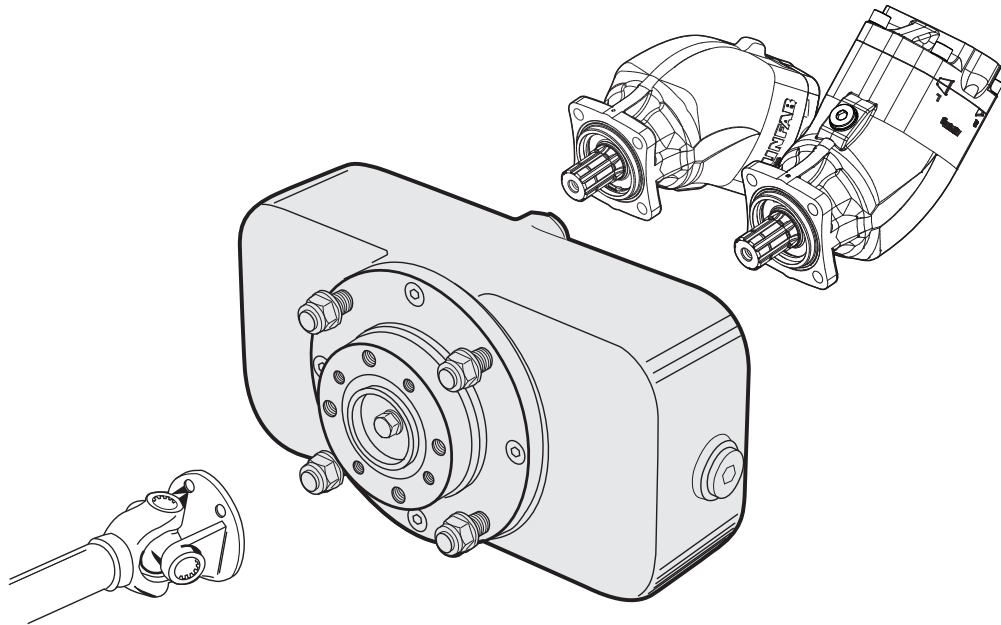

Splitter gearbox
Verteilergetriebe
Fördelningsväxel

SZ 118
SZ 154



	Ratio Übersetzung Utväxling	Type		
Spicer 1300 (B2)	1:1.18	SZ 118	61080	 All
 Page 3:3	1:1.54	SZ 154	61079	 Alle DIN 5462 (ZF) Alla

For detailed information,
see separate Datasheet on
our [website](#).

An adapter flange will be needed for the
Spicer 1400 and the DIN 6-bolt drive
shaft.  Page 3:4

Ausführliche Beschreibung:
Siehe Datenblatt auf
unserer [Website](#)

Bei Zwischenwelle Spicer 1400 und
DIN-Ausführung mit 6 Bohrungen
ist ein Adapterflansch erforderlich.

 Seite 3:4

För detaljerad information se separat
datablad på vår [hemsida](#).

För mellanaxel Spicer 1400 och DIN
6-håls krävs adapterfläns.  Sida 3:4



Splitter Box
Verteilergetriebe
Växellåda

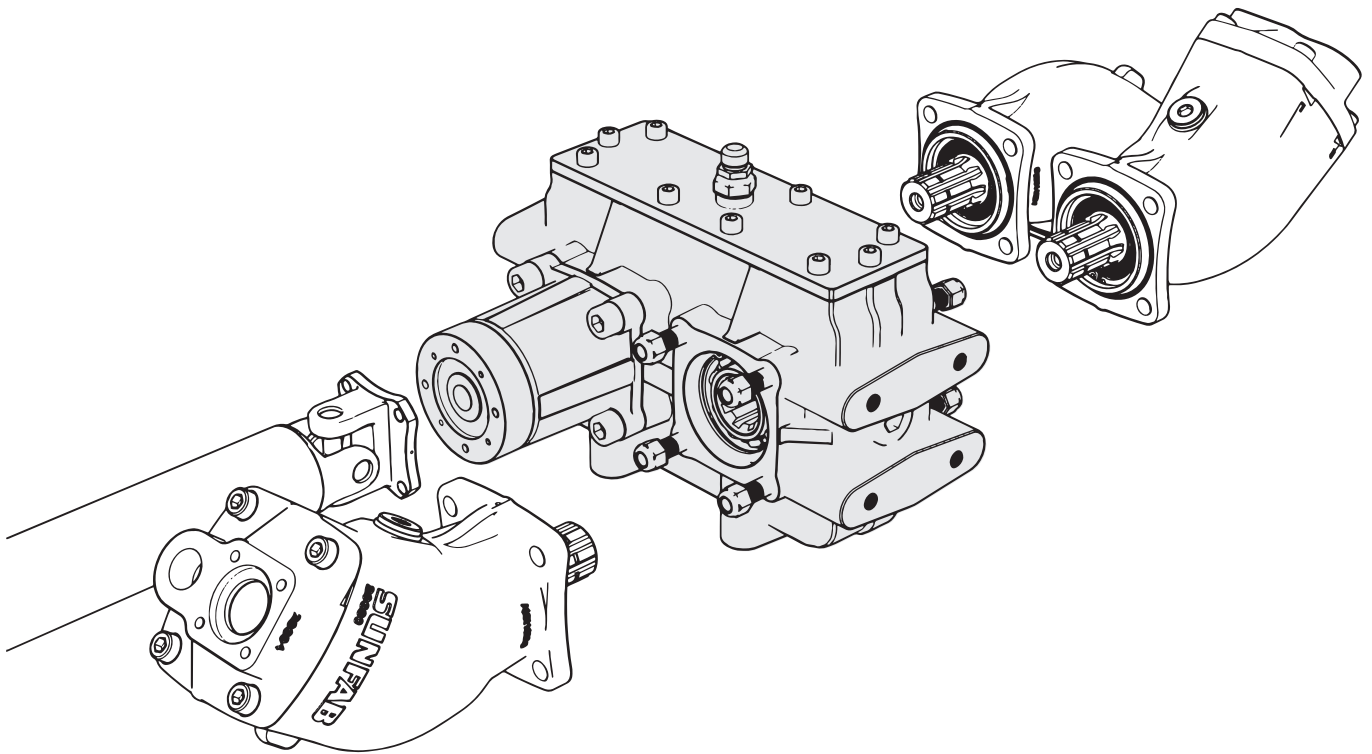

	Ratio Übersetzung Utväxling	Type		
Spicer 1400 (B3) 👉 Page 3:3	1:21	SZ 121	61025 	All Alle DIN 5462 (ZF) Alla

For detailed information, see separate Datasheet on our [website](#).

An adapter flange will be needed for the Spicer 1400 and the DIN 6-bolt drive shaft. 📄 Page 3:4

Ausführliche Beschreibung: Siehe Datenblatt auf unserer [Website](#)

Bei Zwischenwelle Spicer 1400 und DIN-Ausführung mit 6 Bohrungen ist ein Adapterflansch erforderlich. 📄 Seite 3:4

För detaljerad information se separat datablad på vår [hemsida](#).

För mellanaxel Spicer 1400 och DIN 6-håls krävs adapterfläns. 📄 Sida 3:4



Frame attachments & pump suspensions
Rahmenbefestigungen & Pumpenhalterungen
Ramfästen & pumpupphängningar

DIN 5462 (ZF)

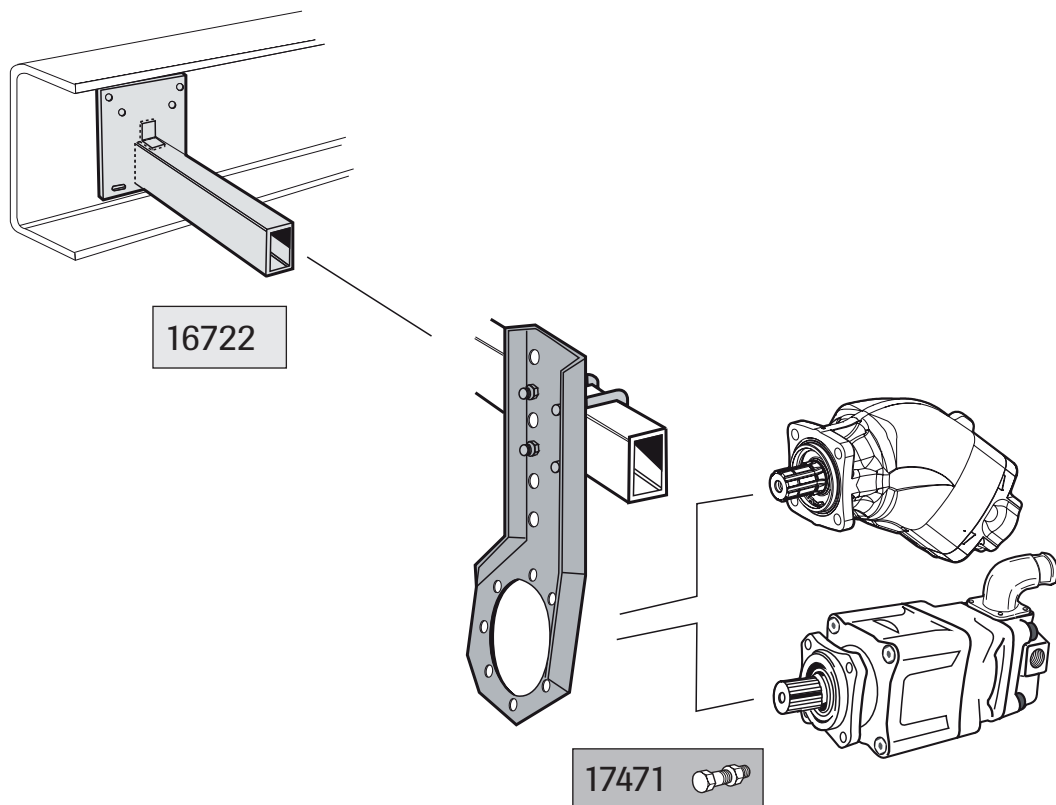



Frame attachments & Gearbox suspensions
Rahmenbefestigungen & Getriebehalterungen
Ramfästen & växelupphängningar
SZ 118/154

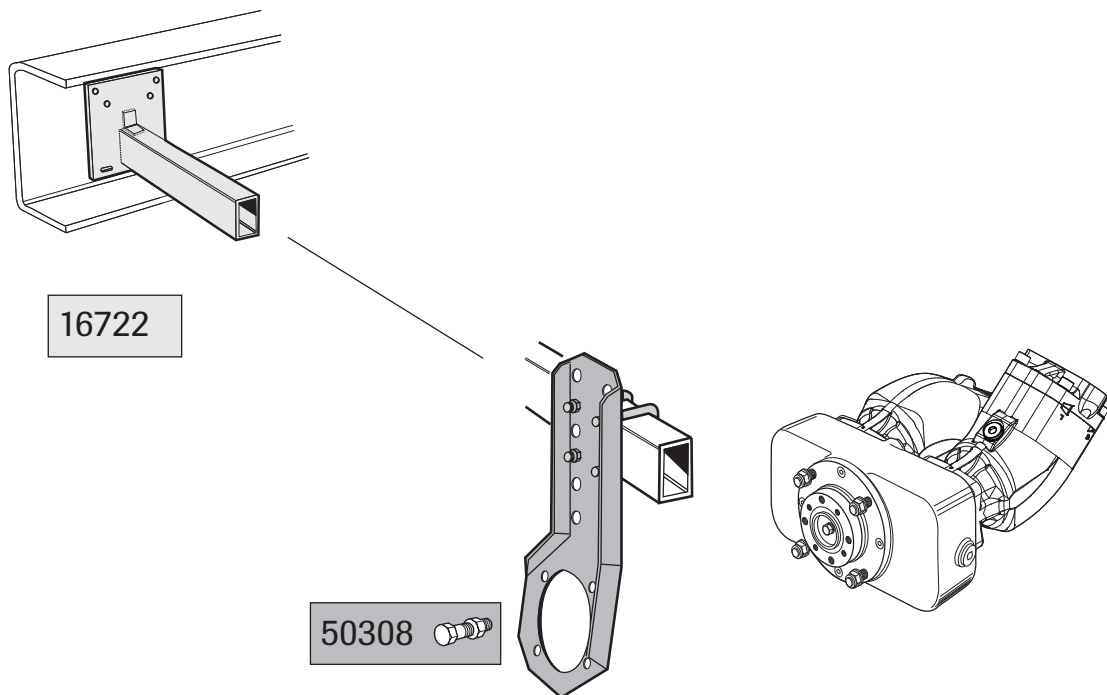



Drive Shafts
Gelenkwellen
Mellanaxlar

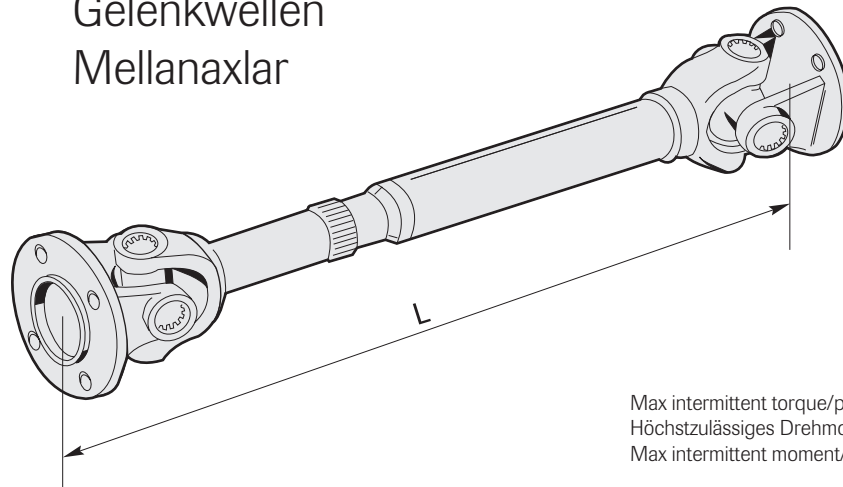

Max intermittent torque/power
Höchstzulässiges Drehmoment/Leistung
Max intermittent moment/effekt

		700 rpm		1500 rpm		
		Nm	kW	Nm	kW	
Spicer 1100 (B1)	16665	250	18	210	32	
Spicer 1300 (B2)	92143	500	36	400	60	
Spicer 1400 (B3)	16667	900	65	700	105	
DIN 4-bolt DIN 4-håls	DIN 4-Loch ☞ Pump16	16665+11915	250	18	210	32

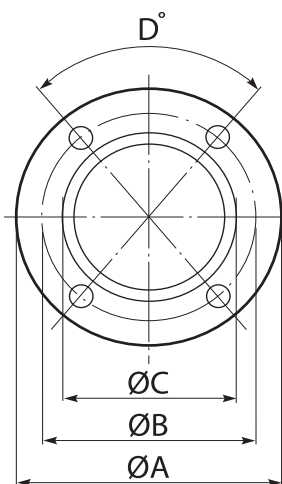

	A	B	C	D	L*
	mm	mm	mm		mm
16665	88	69.9	57.2	80°	1500
92143	97	79.4	60.3	80°	1500
16667	115	95.3	69.9	80°	1500

* Max. length. Customer adjusts length to suit its particular installation. The welded universal joint is delivered in the same parcel as the drive shaft.

For detailed information, see separate installation guide on our [website](#).

* Größte Länge, die bedarfsweise zu kürzen ist. Schweißteil wird lose mitgeliefert.

Ausführliche Beschreibung: Siehe einbauanleitung auf unserer [Website](#).

* Max längd. Aktuell montage-längd anpassas av kund. Svetsknuten levereras lös.



För detaljerad information se separat installationsanvisning på vår [hemsida](#).

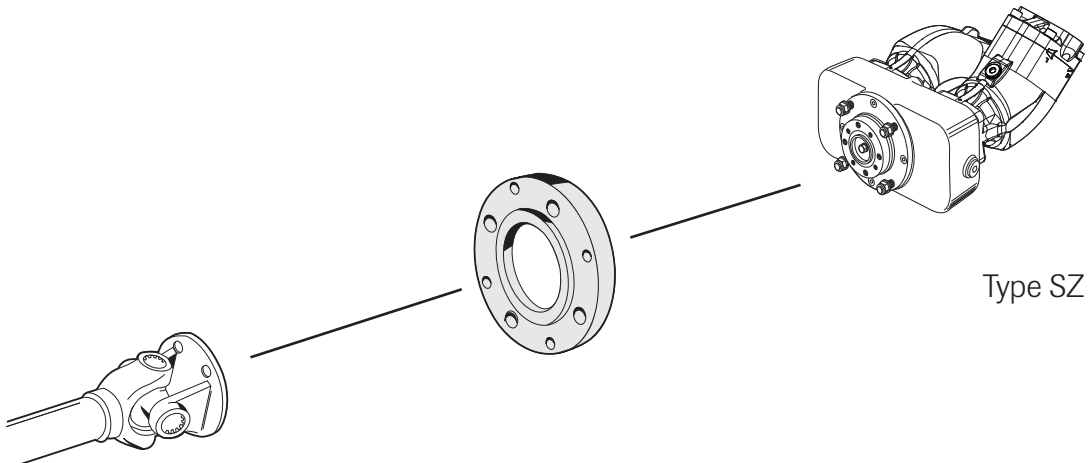

Adapter flange for splitter gearbox
 Adapterflansche für Verteilergetriebe
 Adapterfläns för fördelningsväxel

SZ



Spicer 1400 (B3)	17876 	SZ 118, 154 (B2)  Page 2:3
DIN 6-bolt Ø 100 DIN 6-Loch DIN 6-håls	17638 	

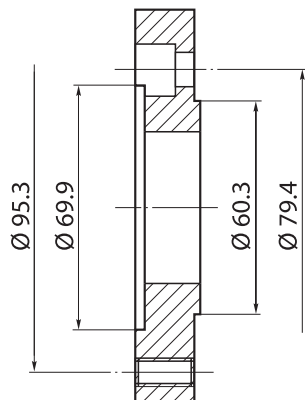

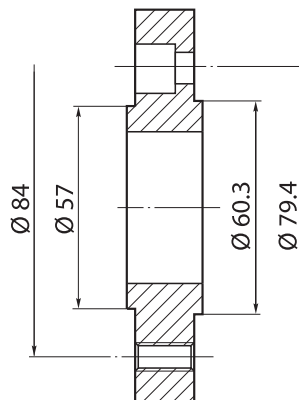

17876

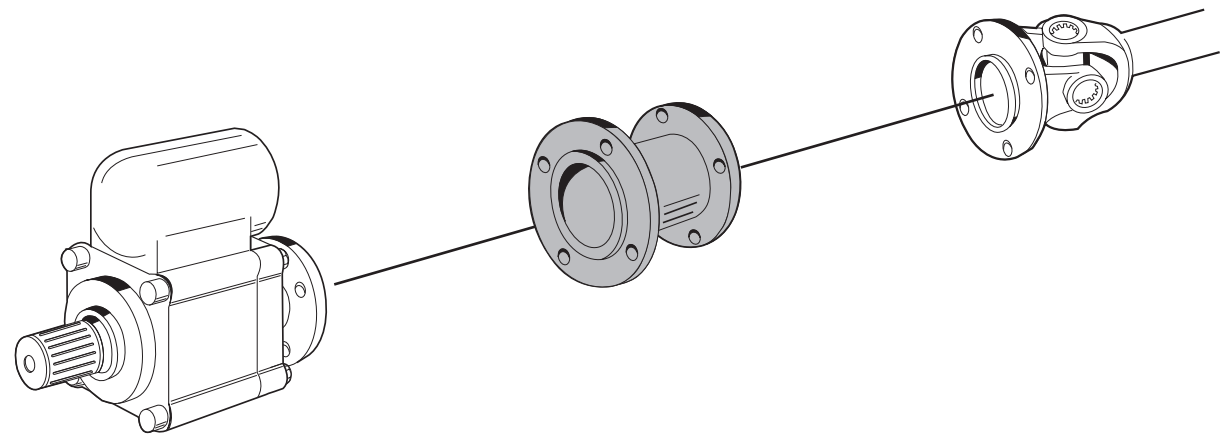

17638

Adapter flanges
 Adapterflansche
 Adapterflänsar



Spicer 1100 (B1)	14064 	Spicer 1300 (B2)	 Page 3:3
------------------	---	------------------	--

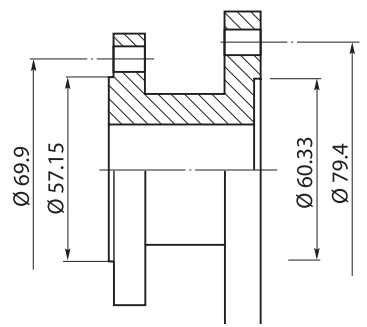





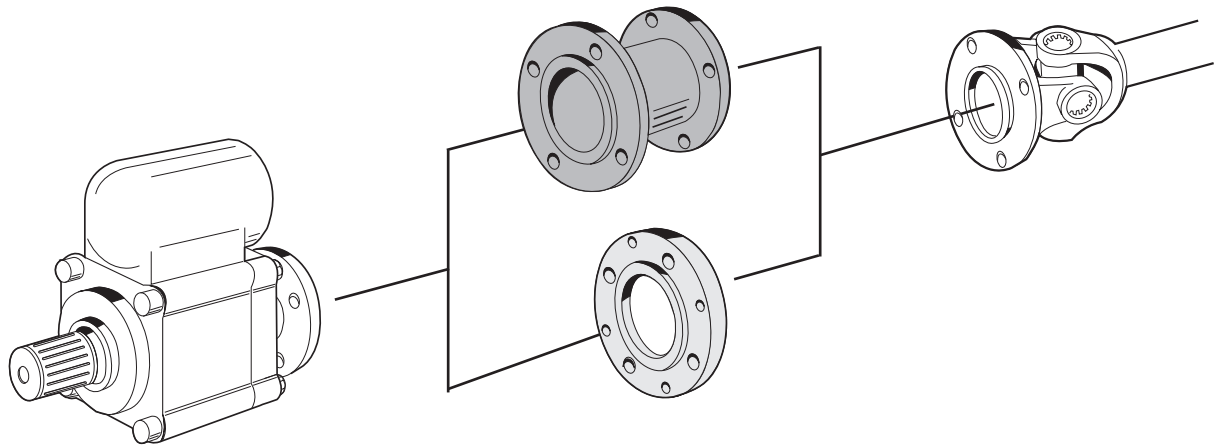

14064

3415GB-DE-SE1909 Rev 1.2



Adapter flanges
 Adapterflansche
 Adapterflänsar



Spicer 1300 (B2)	17355		Spicer 1100 (B1)	 Page 3:3
	17876		Spicer 1400 (B3)	
	18236		DIN 100, 6-bolt DIN 100, 6-Loch DIN 100, 6-håls	
	13631		DIN 120, 8-bolt DIN 120, 8-Loch DIN 120, 8-håls	

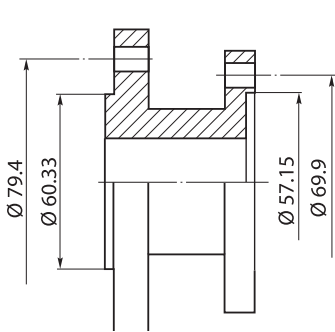

17355

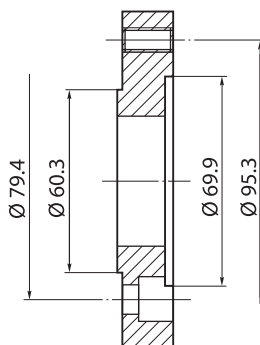

17876

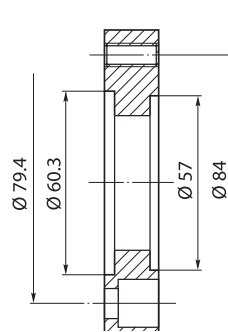

18236

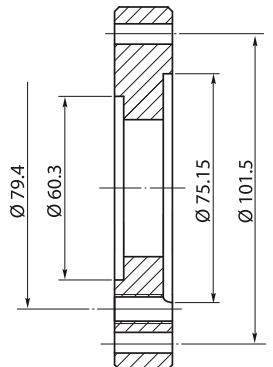





13631

3416GB-DE-SE1909 Rev 1.1

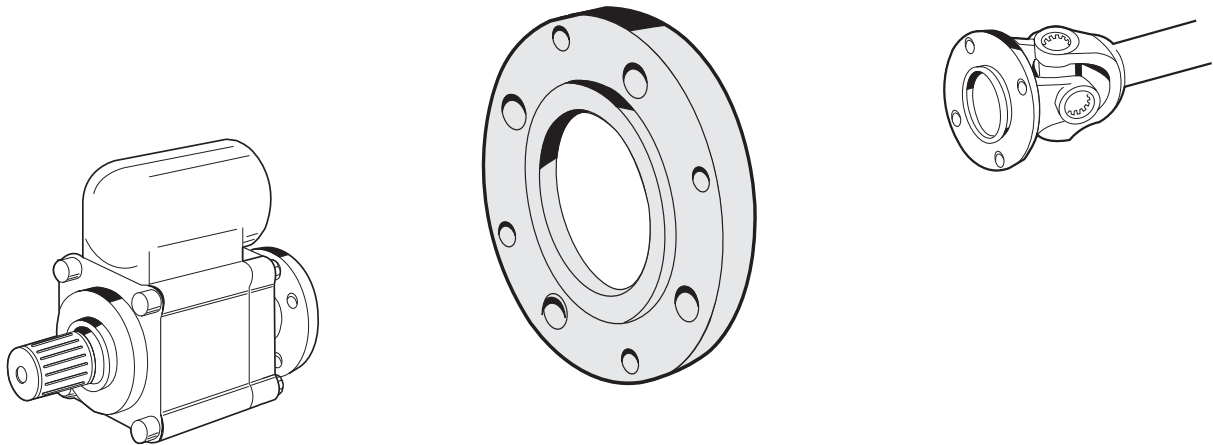

Adapter flanges
 Adapterflansche
 Adapterflänsar



Spicer 1400 (B3)	13740 	Spicer 1300 (B2)
	11656 	Spicer 1100 (B1)
DIN 4-bolt Ø90 DIN 4/6-Loch DIN 4/6-håls	11915 	

Page 3:3

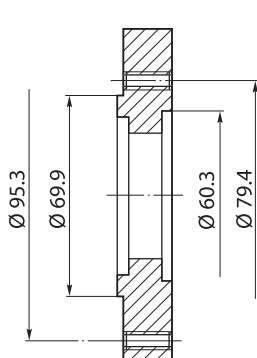

13740

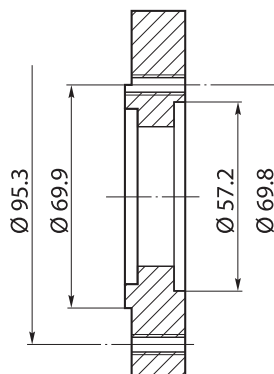

11656

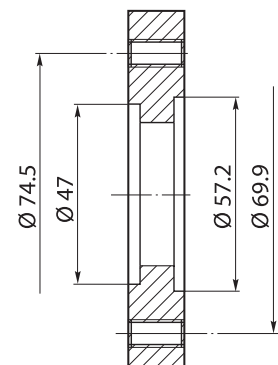

11915



Adapter flanges
 Adapterflansche
 Adapterflänsar

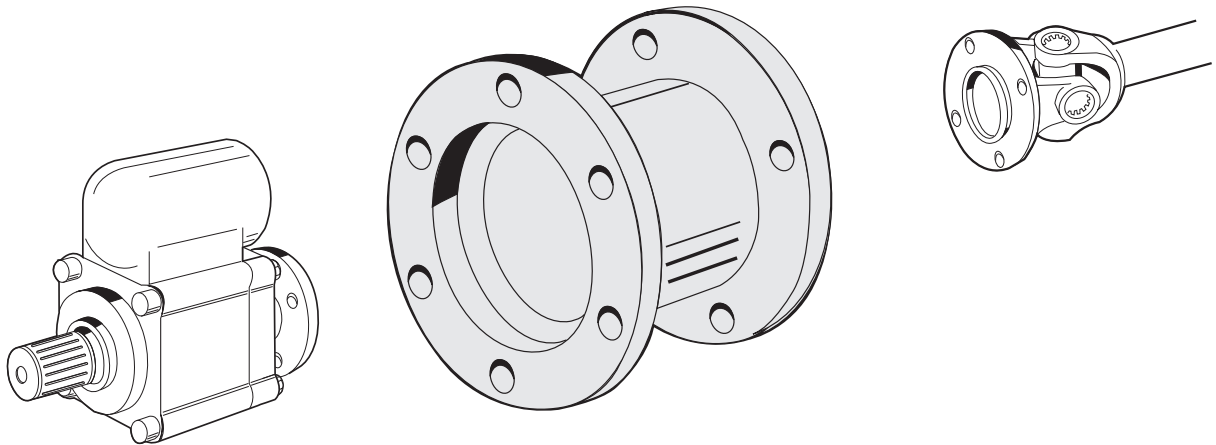

6 bolt DIN 6 Loch Ø75 6 håls	14063	Spicer 1100 (B1)	Page 3:3
	14062	Spicer 1300 (B2)	

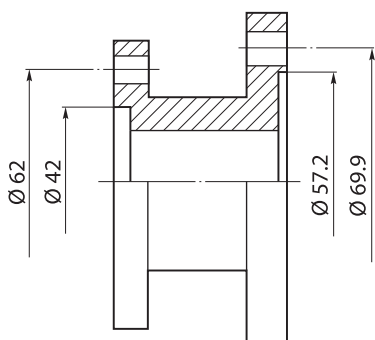

14063

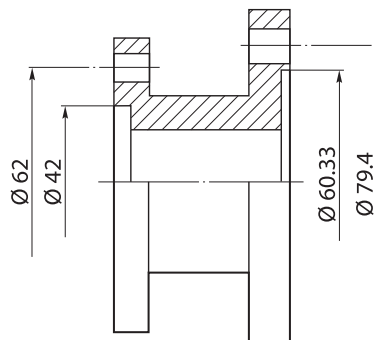



14062

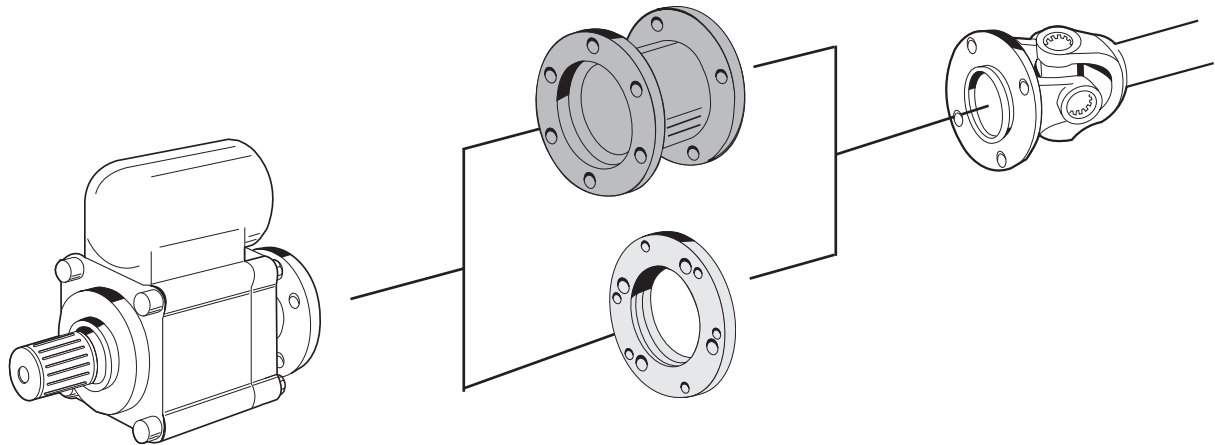

Adapter flanges
 Adapterflansche
 Adapterflänsar



6 bolt DIN 6 Loch Ø 100 6 håls	18287 	Spicer 1100 (B1)	Page 3:3
	18236 	Spicer 1300 (B2)	
	18020 	Spicer 1400 (B3)	

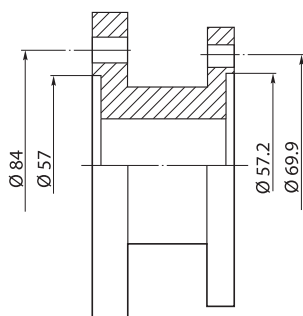

18287

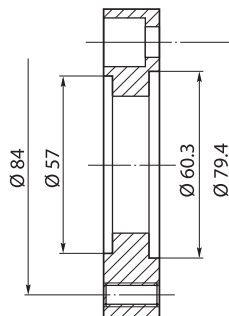

18236

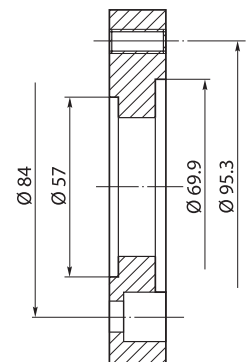

18020



Splined drive flanges Keilwellen-Mitnehmerflansche Medbringare med splines

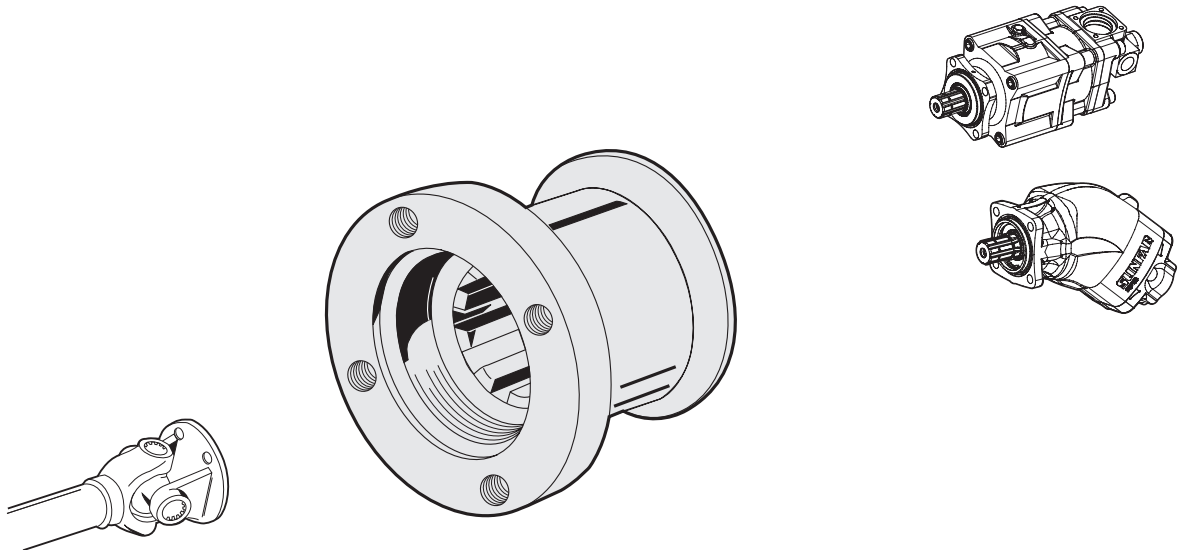

Pump 12	Spicer 1100 (B1)	16643		All pumps Alle Pumpen Alla pumpar
	Spicer 1300 (B2)	17335		
	Spicer 1400 (B3)	18150		
DIN 4-bolt DIN 4-Loch DIN 4-håls	17010			

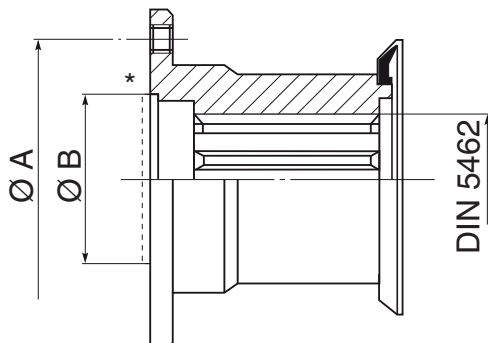

	A mm	B mm
16643	69.9	57.2
17335	79.4	60.3
18150	95.3	69.9
17010	74.5	47.0*

- * External guide
- * Äußere Führung
- * Utvändig styrning

Note: The drive flanges are supplied complete with bolts, washers and dust excluder.

Bemerkung: Schrauben, Scheiben und Staubschutz sind im Lieferumfang enthalten.

Anm: Medbringarna levereras komplett med skruvar, brickor och dammskydd.





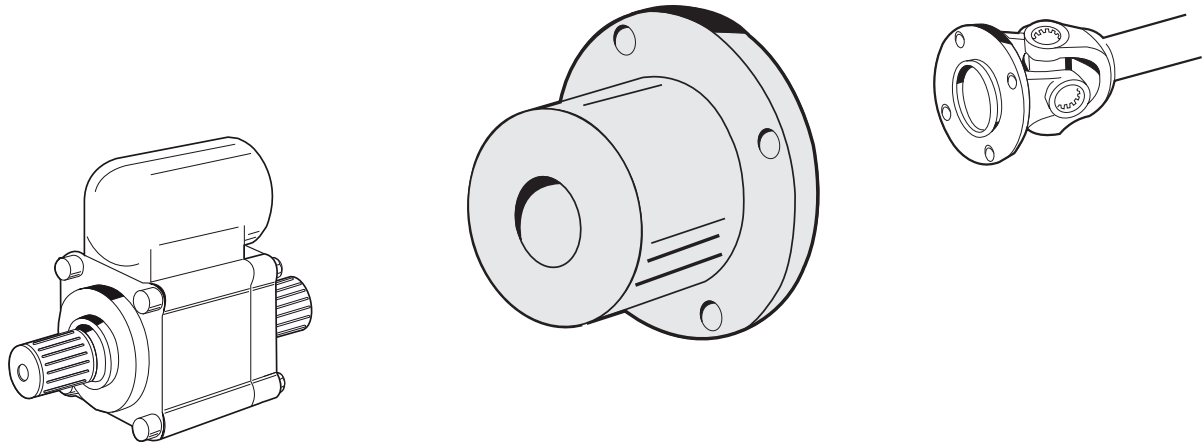

Neutral Drive Flanges

Neutrale Mitnehmerflansche

Neutrala medbringarflänsar



Shaft Welle Axel	10325 	Spicer 1100 (B1)	
	15362 	Spicer 1300 (B2)	
	16670 	Spicer 1400 (B3)	
	17764 	DIN 4-bolt DIN 4-Loch	DIN 4-håls
	17765 	DIN 6-bolt DIN 6-Loch	Ø100 DIN 6-håls

Page 3:3

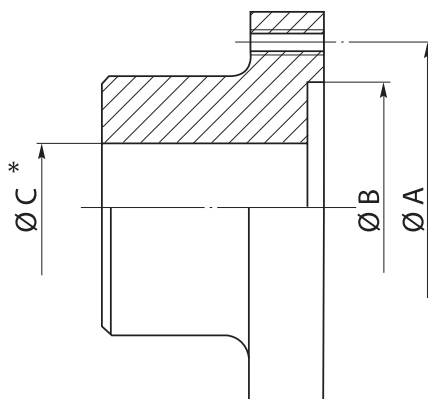





	A mm	B mm	C mm
10325	69.9	57.2	18*
15362	79.4	60.3	20*
16670	95.3	69.9	20*
17764	74.5	47.0	18*
17765	84.0	57.0	20*

* To be finished
 * Auf Fertigmaß bearbeiten
 * Skall slutbearbetas

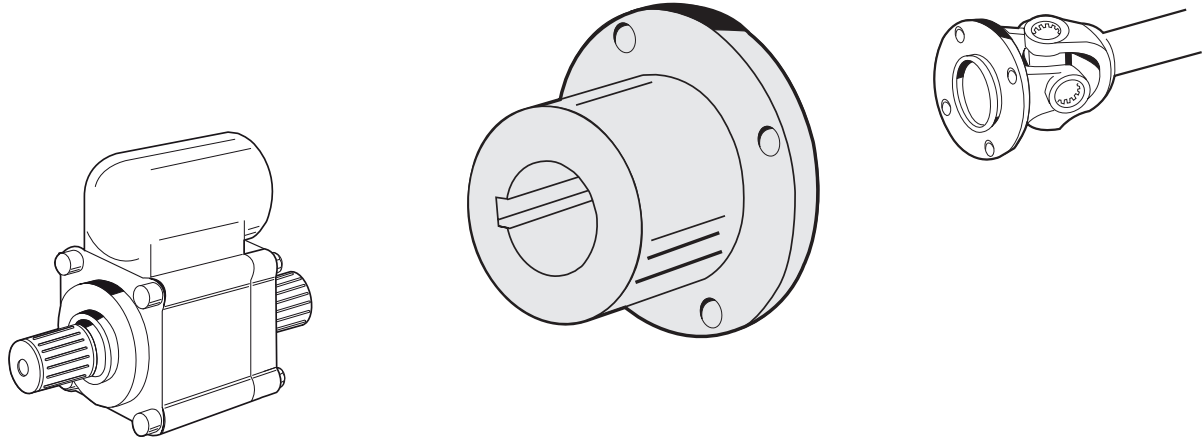

Drive flanges
 Mitnehmerflansche
 Medbringarflänsar
 1 1/4"



SAE standard SAE-Norm	16541 	Spicer 1100 (B1)	Page 3:3 
	16639 	Spicer 1300 (B2)	

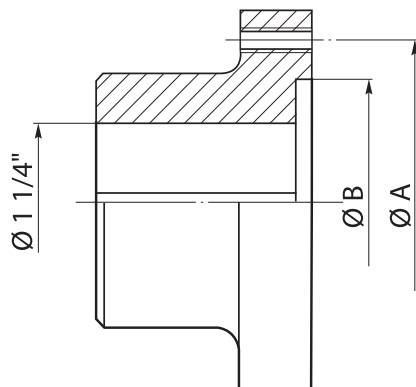

	A mm	B mm
16541	69.9	57.2
16639	79.4	60.3



Splined drive flanges
 Keilwellen-Mitnehmerflansche
 Medbringare med splines

SAE-B

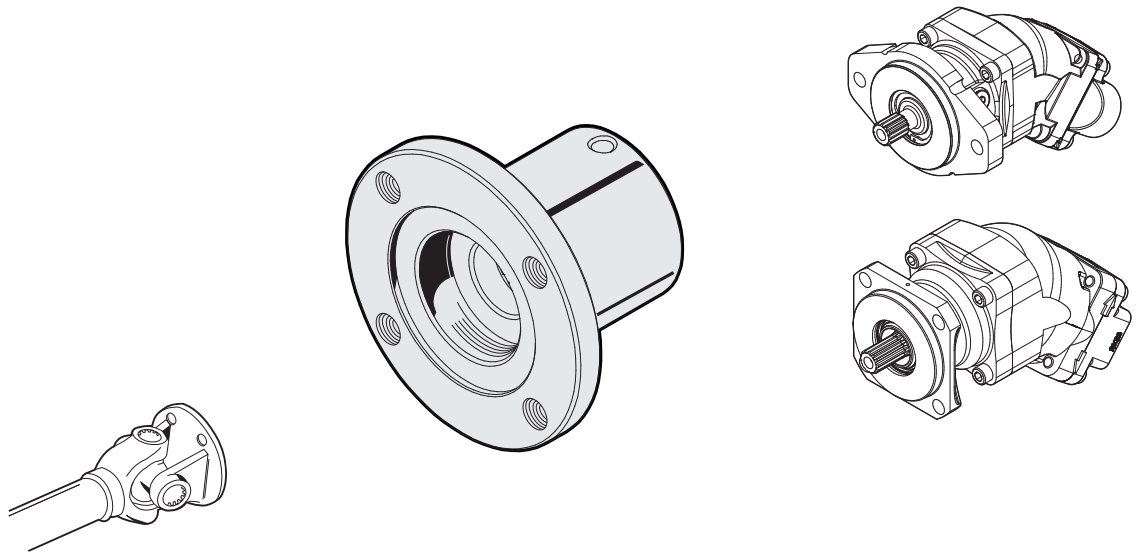

Page 3:3

Spicer 1300 (B2)	61154	SAE-B 13T 16/32
------------------	-------	-----------------

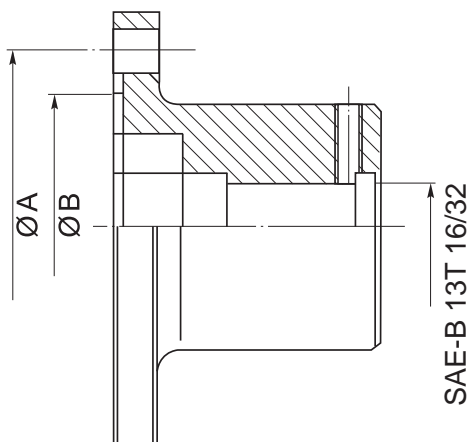

	A mm	B mm
61154	79.4	60.3



Splined drive flanges
Keilwellen-Mitnehmerflansche
Medbringare med splines

SAE-C

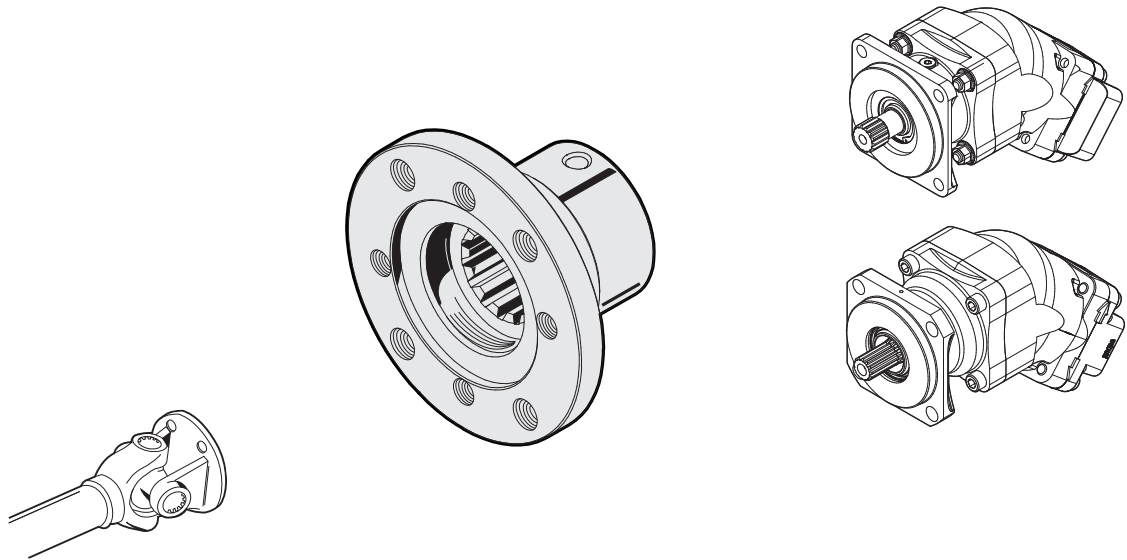

Page 3:3	Spicer 1100 (B1)	61054	SAE-C 14T 12/24
	Spicer 1300 (B2)	61054	

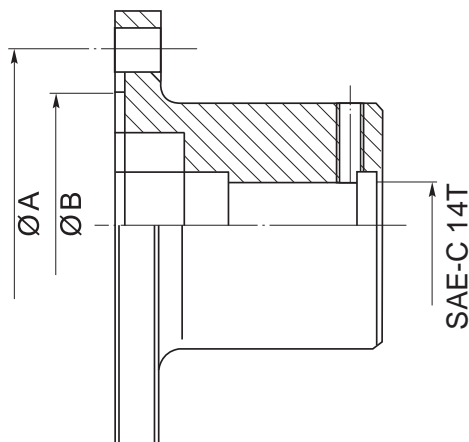

	A mm	B mm
61054 (1100)	69.9	57.2
61054 (1300)	79.4	60.3



Splined drive flanges
 Keilwellen-Mitnehmerflansche
 Medbringare med splines

6 - SP/1 3/8"

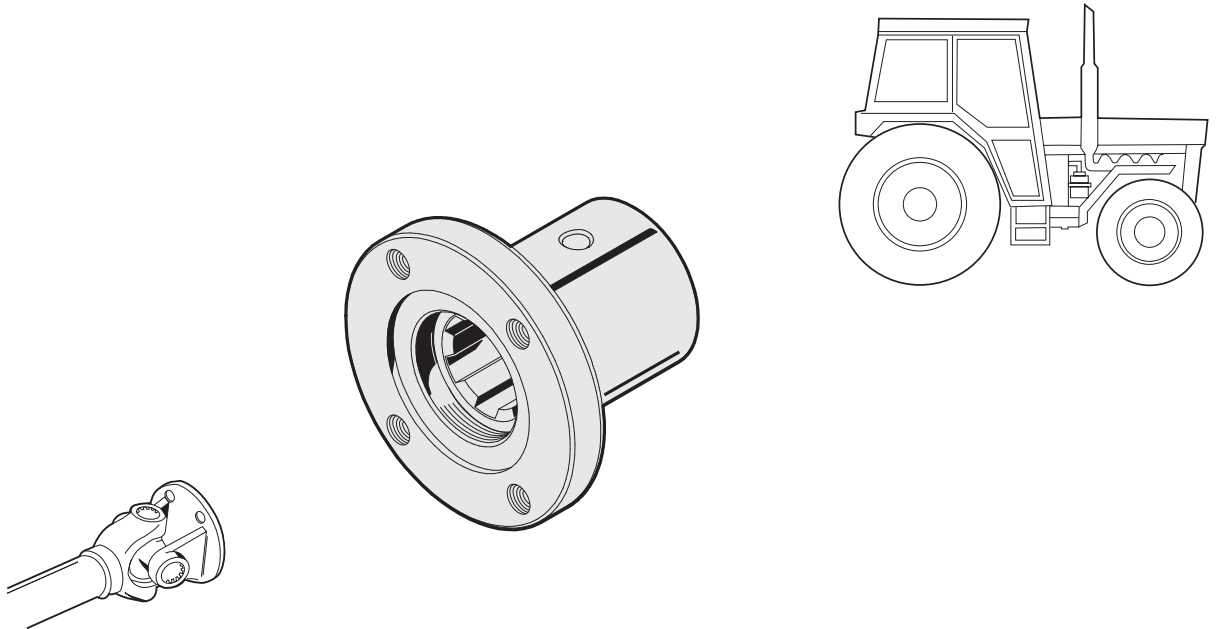

<p>☞ Page 3:3 SAE 1300</p>	<p>61050 </p>	<p>1300-6 - SP/1 3/8"</p>
----------------------------	---------------	---------------------------

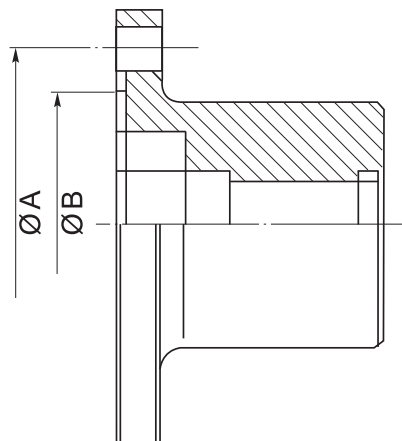

	A mm	B mm
61050	79.35	60.35



Drive-flange & adapter for DIN power take off Antriebsflansch & Adapter für DIN-Nebenantriebe Drivfläns & adapter för DIN kraftuttag

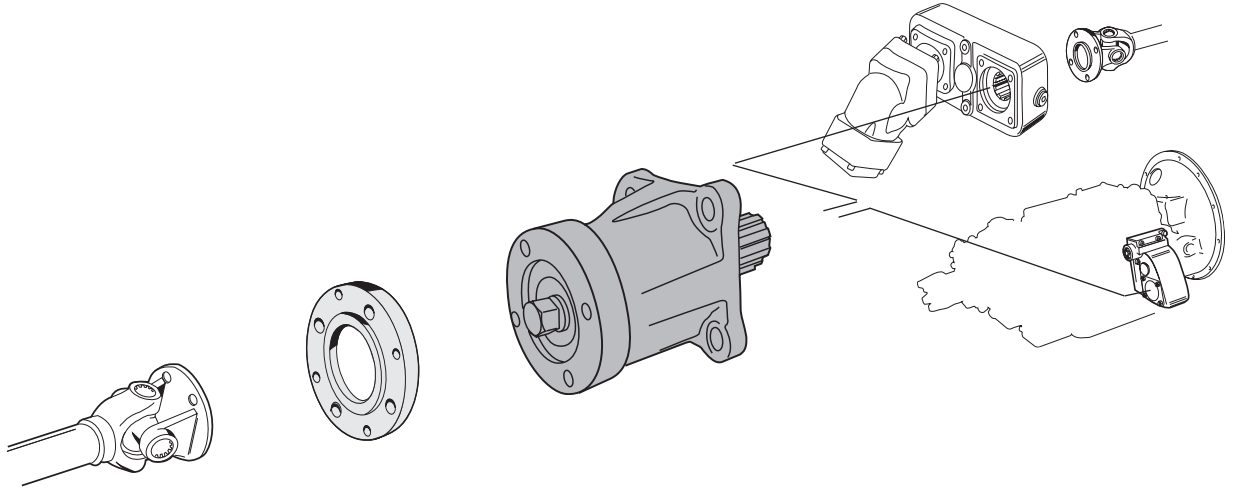

Page 3:3	Spicer 1100 (B1)	—	61040	DIN 5462 (ZF)	
	Spicer 1300 (B2)	—	61015		
	Spicer 1400 (B3)	—	61017		
	DIN 4-bolt DIN 4-Loch	DIN 4-håls	11915		61040
	DIN 6-bolt DIN 6-Loch	Ø 100 DIN 6-håls	18236		61015

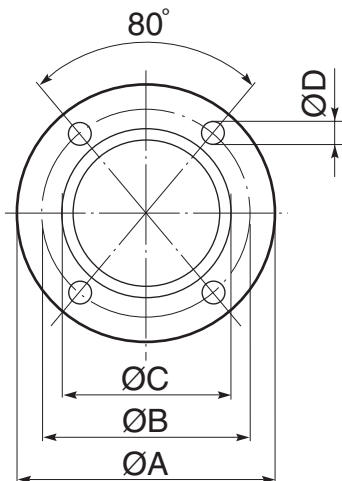

	A	B	C	D
	mm	mm	mm	mm
Spicer 1100 (B1)	88	69.9	57.2	8.5
Spicer 1300 (B2)	97	79.4	60.3	10.5
Spicer 1400 (B3)	115	95.3	69.9	10.5

Torque / Leistung / Moment *

Spicer 1100 (B1)	300 Nm
Spicer 1300 (B2)	450 Nm
Spicer 1400 (B3)	600 Nm

* Driveshaft / Swischenwelle / Mellanaxel



Special Adapter
 Spezialadapter
 Specialadapter

SCANIA

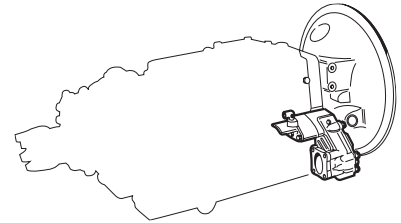
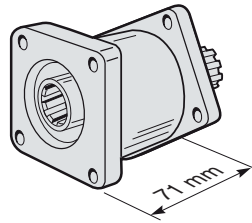
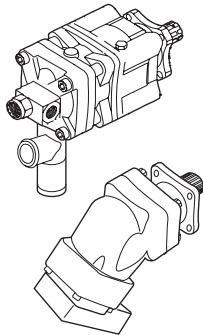

SAP-SCP-SAPT+By Pass SLPD Savtec	61024	PTO ED 140
-------------------------------------	-------	------------

Special Adapter
 Spezialadapter
 Specialadapter

UNIMOG

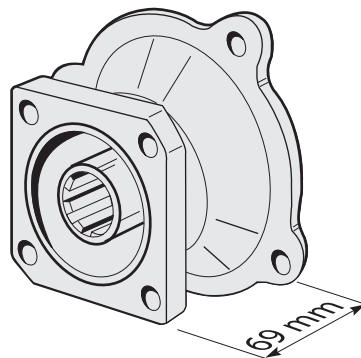
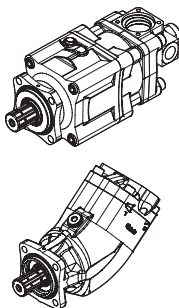

All Alle DIN 5462 (ZF) Alla	61012	PTO N16
-----------------------------------	-------	---------



Distance Adapter Kit
 Abstandadapter-Bausatz
 Distansadaptersats

DIN 5462

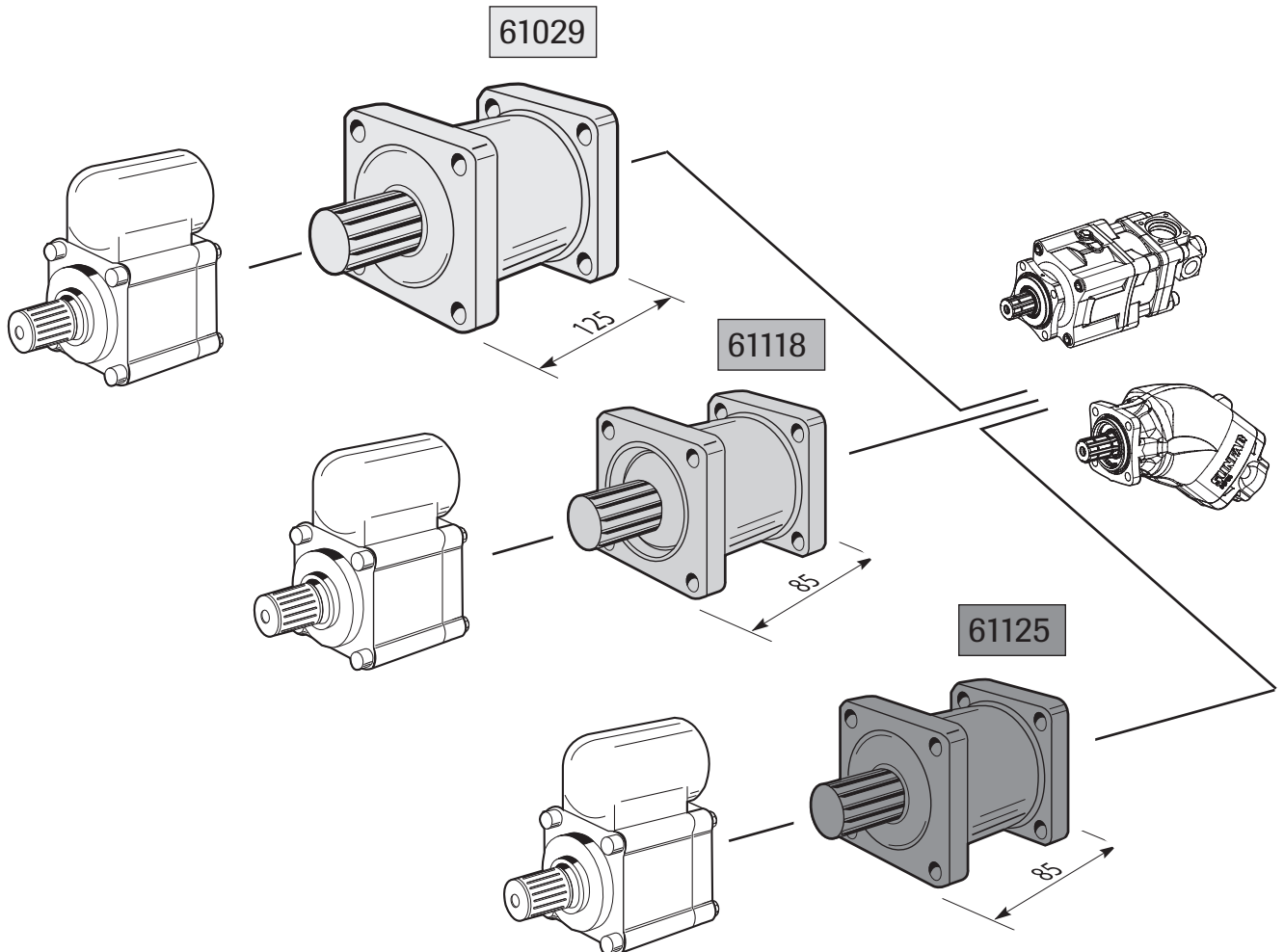

ZF PTO type ... / 1c, 2c, 3c	61029	Supported/Gelagert/Lagrad	All Alle DIN 5462 (ZF) Alla
ZF PTO type ... / 1a, 2a, 3a	61118	—	
ZF PTO type ... / 1a, 2a, 3a	61125	Supported/Gelagert/Lagrad	



Special Adapter
Spezialadapter
Specialadapter

6 - SP/1 3/8"

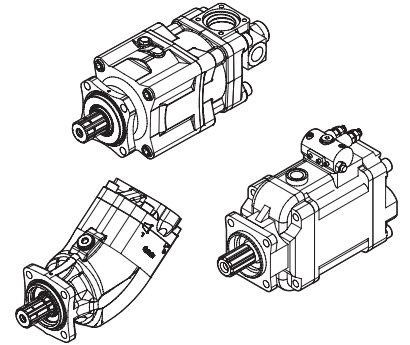
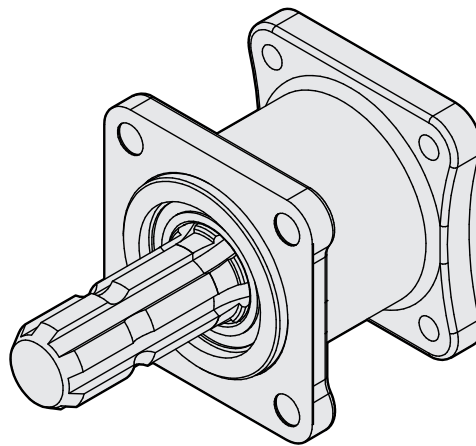
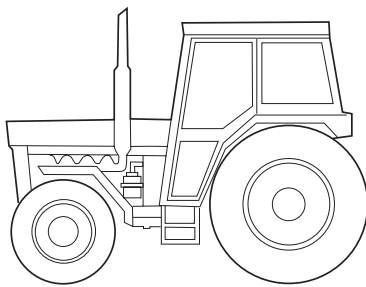

DIN 9611	61112	600Nm	All Alle DIN 5462 (ZF) Alla
----------	-------	-------	-----------------------------------



Adapter
Adapter
Adapter

SAE-B 13T

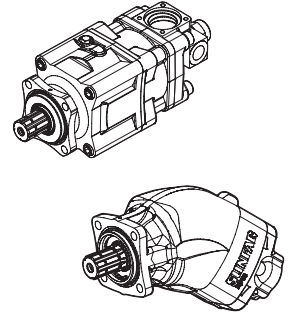
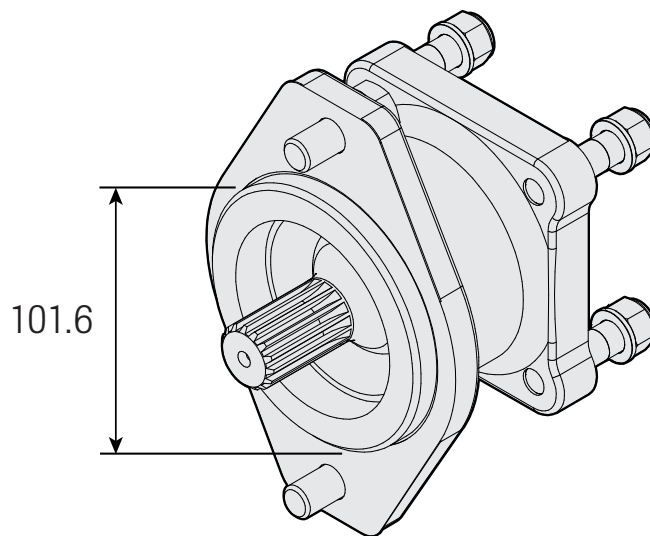

SAE-B 2	61058	300Nm	DIN 5462 (ZF)
---------	-------	-------	---------------



Adapter
 Adapter
 Adapter

SAE-B B 15T

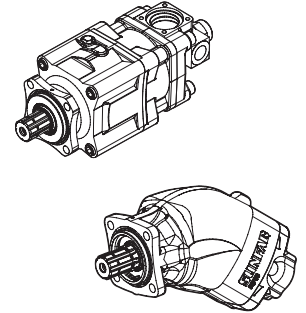
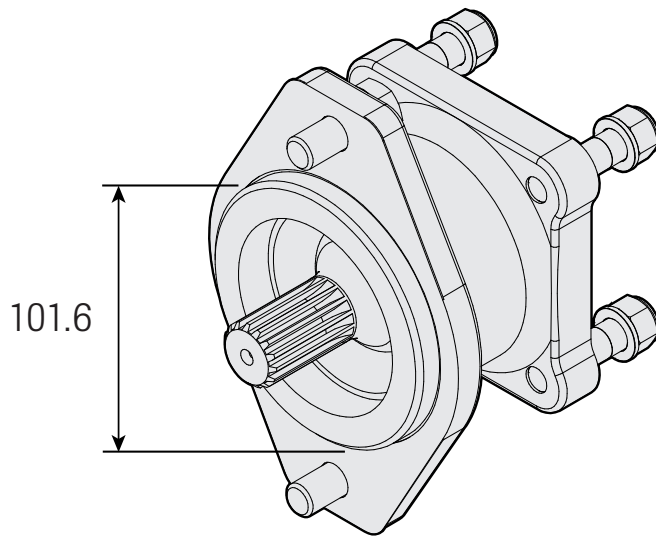

SAE-B 2	61055	450Nm	DIN 5462 (ZF)
---------	-------	-------	---------------



Adapter
Adapter
Adapter

UNI 8953

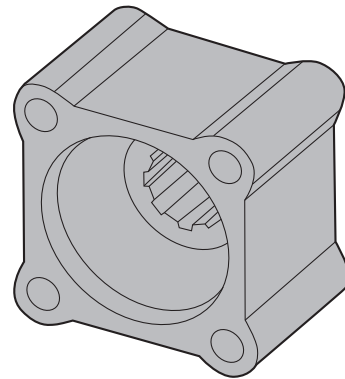
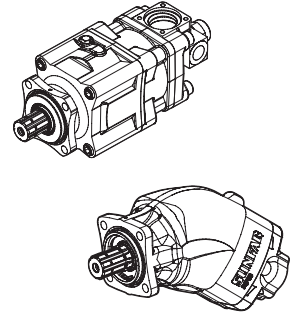
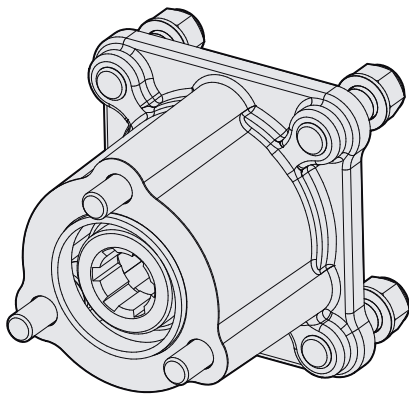

UNI 8953	61109	250 Nm	All
	60057	300 Nm	Alle DIN 5462 (ZF) Alla



BY-PASS valve
 BY-PASS ventil
 BY-PASS ventil

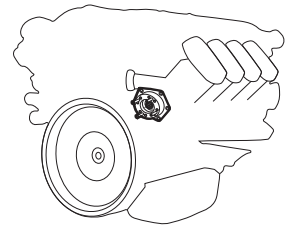
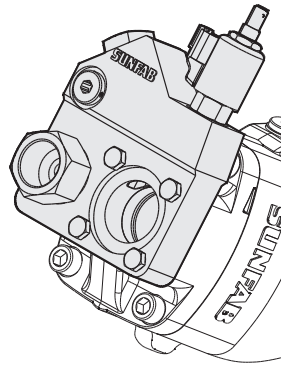
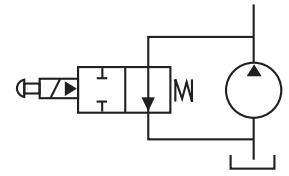

SAP, SCP 012-064	12V	91071	Engine-mounted power take off Am Motor montierter Nebenabtrieb Motormonterat kraftuttag
SAPT 090	24V	91073	
SAP, SCP 084-108	12V	91075	
SAPT 130	24V	91077	
Cable 2.5m - Deutsch connector		91078	

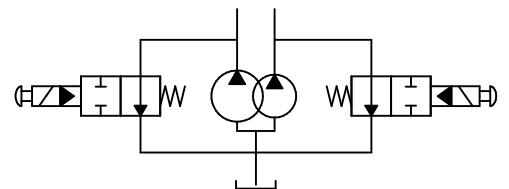
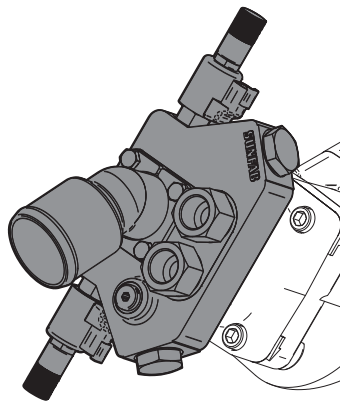
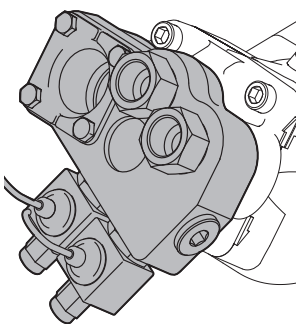

SCPD-56/26	12V	-	Engine-mounted power take off Am Motor montierter Nebenabtrieb Motormonterat kraftuttag
	24V	20536	
SCPD-70/36	12V	91171	
	24V	91170	
Cable 2.5m - Deutsch connector		91078	

For detailed information,
 see separate Datasheet on
 our [website](#).

Ausführliche Beschreibung:
 Siehe Datenblatt auf
 unserer [Website](#).

För detaljerad information se separat
 datablad på vår [hemsida](#).



Pressure relief valve
 Druckbegrenzungsventil
 Tryckbegränsningsventil

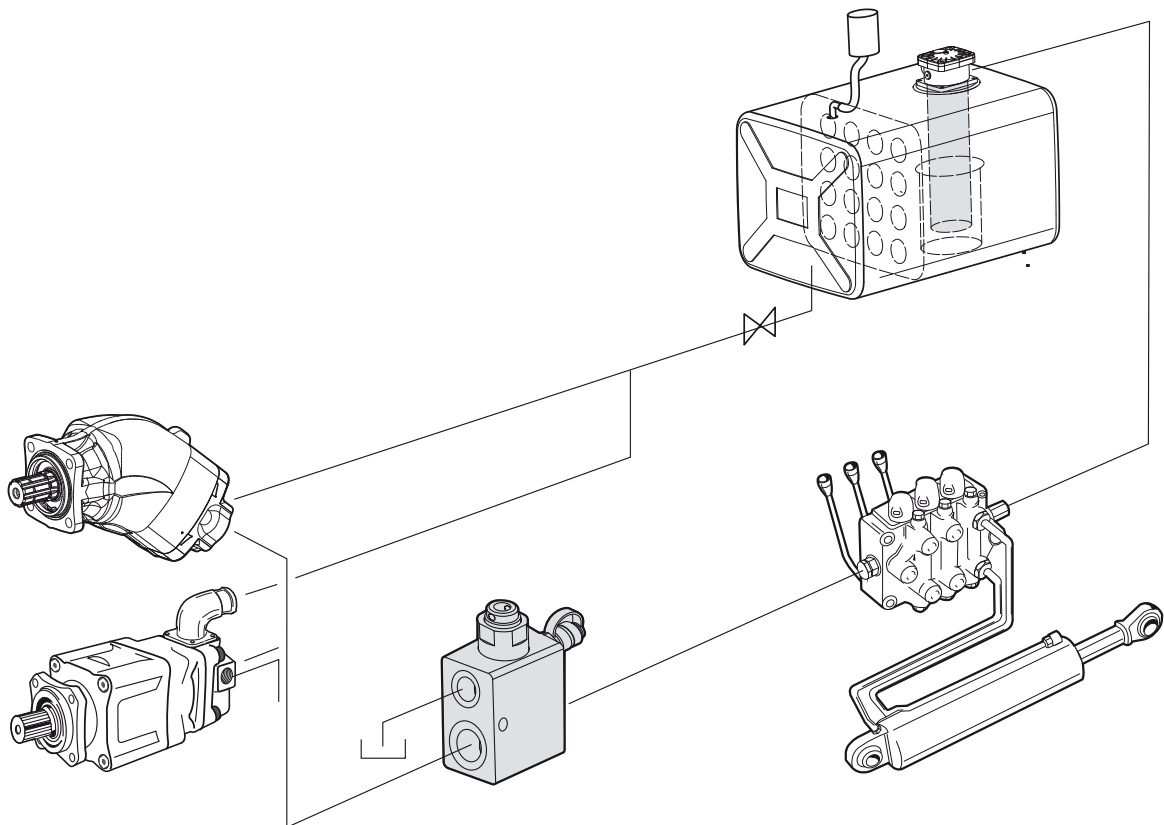

All pumps Alle Pumpen Alla pumpar	90086 G3/4" 32 Mpa 90087 G1" 32 Mpa 90076 G3/4" 42 Mpa 90029 G1" 42 Mpa	Equipment Ausrüstung Utrustning
---	--	---------------------------------------

For detailed information,
 see separate Datasheet on
 our [website](#).

Ausführliche Beschreibung:
 Siehe Datenblatt auf
 unserer [Website](#).

För detaljerad information se separat
 datablad på vår [hemsida](#).



Directional valve 3/2
 Wegeventil 3/2
 Rikningsventil 3/2

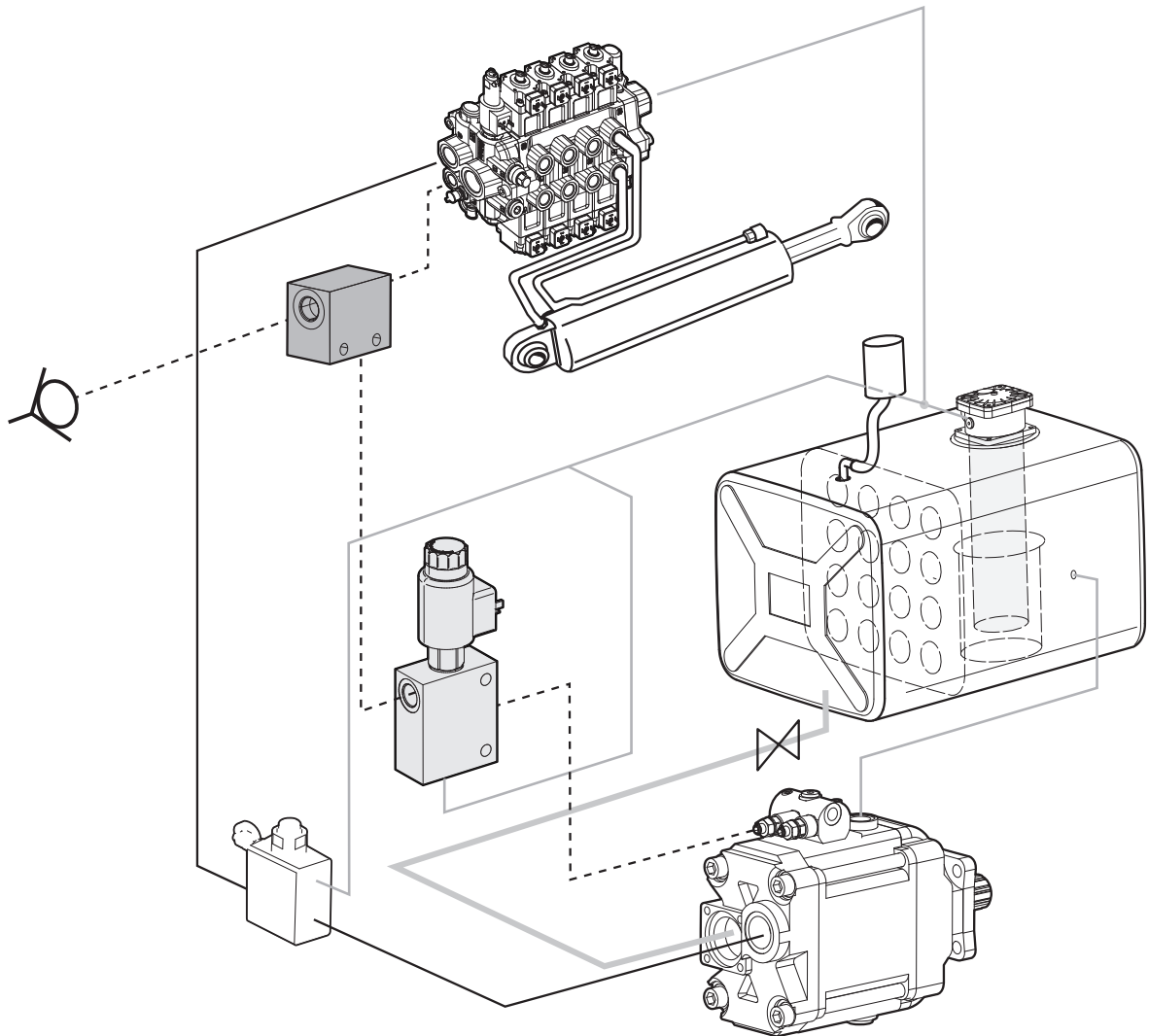
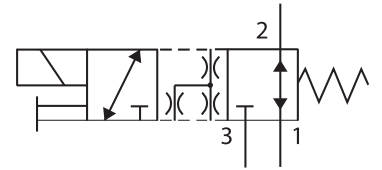

SVH	50922 (12V) 50863 (24V)	Equipment Ausrüstung Utrustning
-----	----------------------------	---------------------------------------

For detailed information,
 see separate Datasheet on
 our [website](#).

Ausführliche Beschreibung:
 Siehe Datenblatt auf
 unserer [Website](#).

För detaljerad information se separat
 datablad på vår [hemsida](#).



High Pressure Filter LS
 Hochdruckfilter LS
 Högtrycksfilter LS



92287

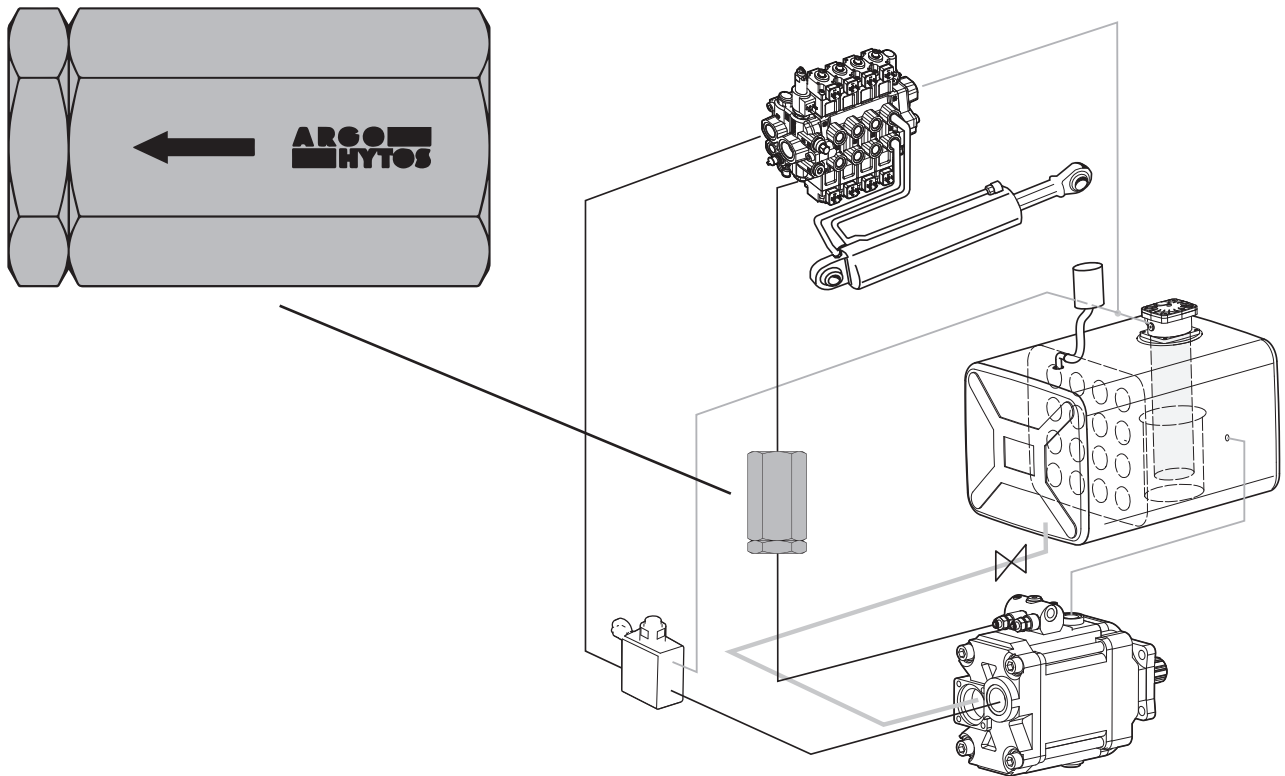

		l/min	Max pressure Max druck Max tryck	L	Degree of filtration Abscheidungsgrade Filtreringsgrad	Connections Anschlüssen Anslutningar
SVH	92287	7	500 bar	72 mm	10 µm	G 1/4"



Shuttle valve
Wechselventil
Skyttelventil

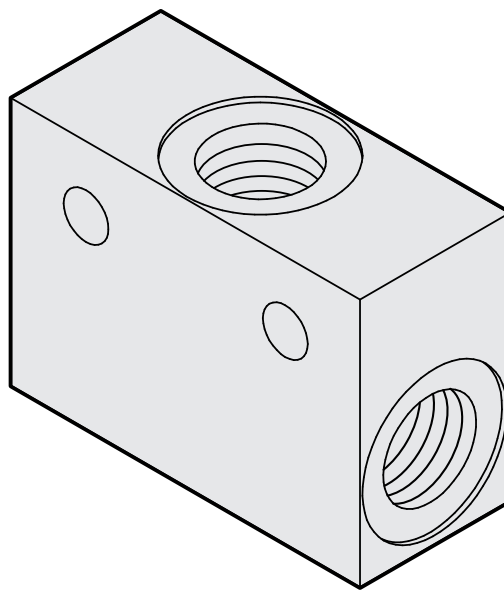
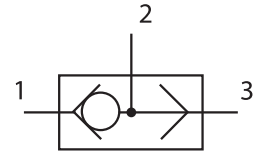

		l/min			Max pressure Max druck Max tryck	
SVH	91115	Female/Female	1/4 G	1 - 20	700 bar	Equipment Ausrüstung Utrustning
	91116	Female/Female	1/2 G	10 - 60	700 bar	



Anti-Cavitation Valve
Nachsaugventil
Anti-kavitationsventil

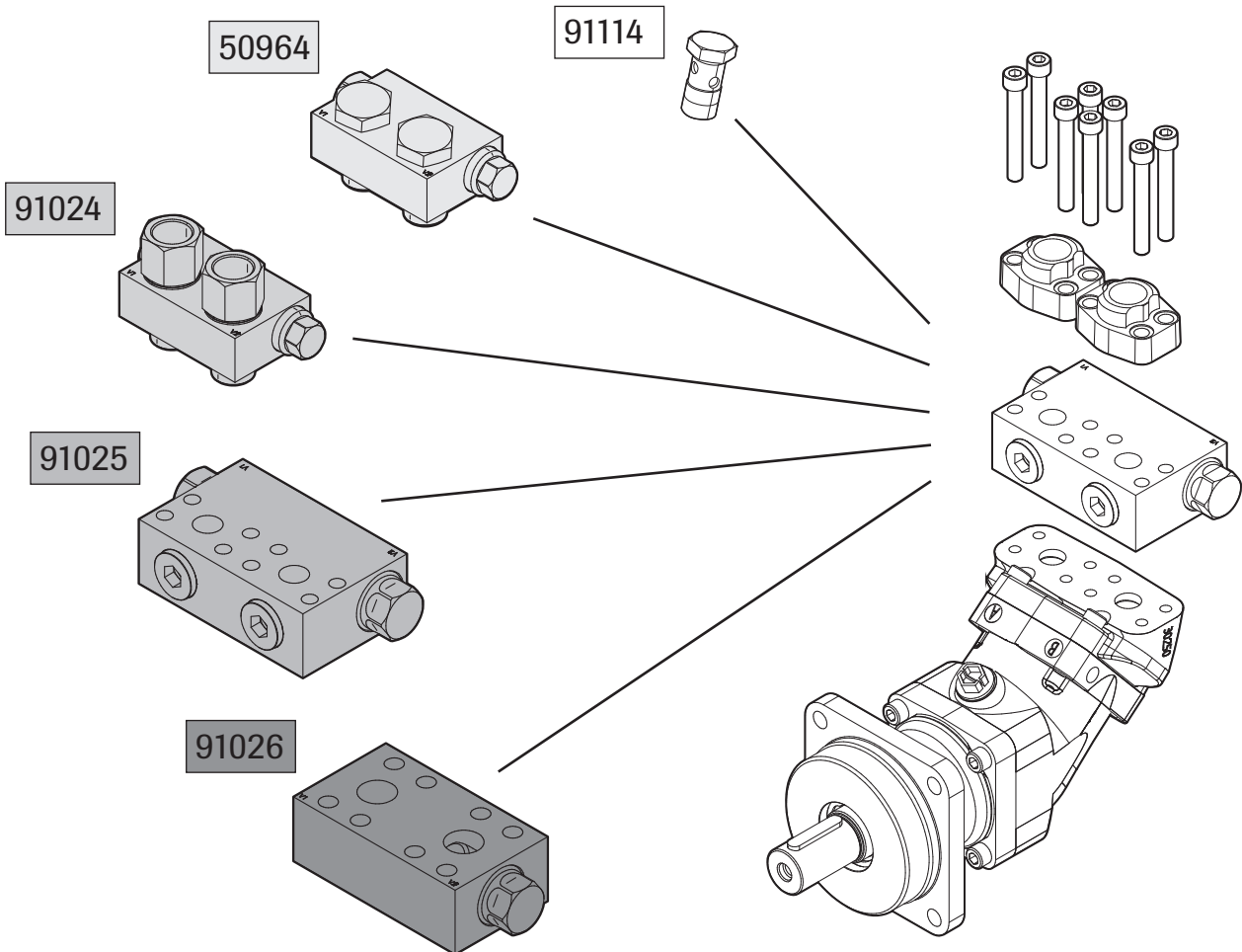
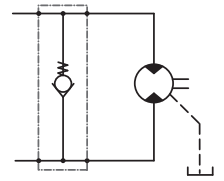

SCM	010-034	010-034	040-064	084-130
Valve/Ventil/Ventil	50964	91024	91025	91026
Flange/Flanche/Fläns	—	—	50857	50858
Bolt kit/Schraubensatz/Bultsats	—	—	50854	50855
Banjo bolt/Hohlschraube/Banjobult	91114	91114	G3/4	G1"
Cover/Deckel/Lock		K3G	V2/S2	V1

For detailed information, see separate Datasheet on our [website](#).

Ausführliche Beschreibung: Siehe Datenblatt auf unserer [Website](#).

För detaljerad information se separat datablad på vår [hemsida](#).



Flushing Valve
Spülventil
Spolventil

91019-170

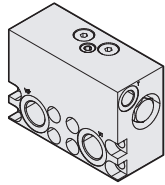

91020-190

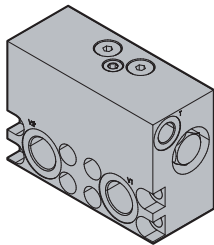

91021-210

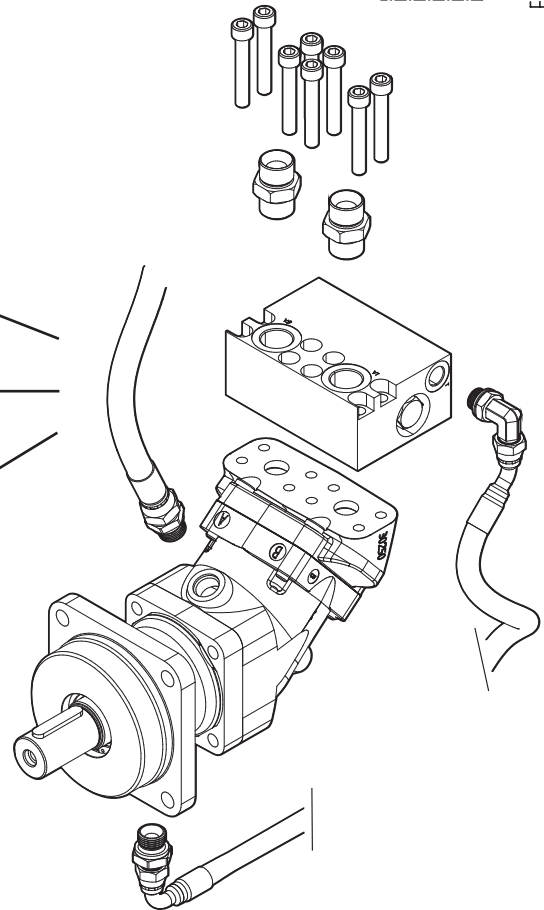
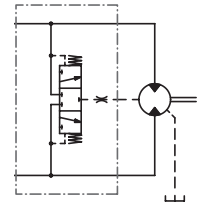
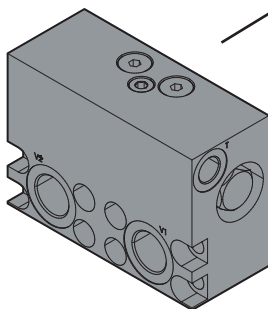

SCM	025-034			040-064		084-130		
Valve/Ventil/Ventil	91019-170			91020-190		91021-210		
Bolt kit/Schraubensatz/Bultsats	50851			50852		50853		
Hose kit/Schlauchsatz/Slangsats	M2	ISO	SAE	M2/ISO	SAE	M2/ISO	SAE-C	SAE-D
Pos 1*	50847	50848	50949	50848	50949	50848	50949	50949
Pos 2*	50847	50848	50948	50849	50950	50850	50950	50952
Cover/Deckel/Lock	V2			V2		V2		

*For detailed information, see separate Datasheet on our [website](#).

*Ausführliche Beschreibung: Siehe Datenblatt auf unserer [Website](#).

*För detaljerad information se separat datablad på vår [hemsida](#).



Injector
Injektoren
Injektor

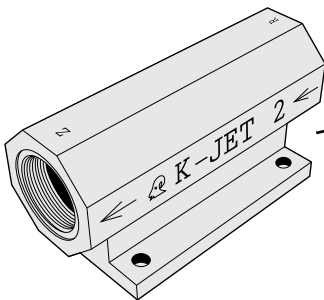
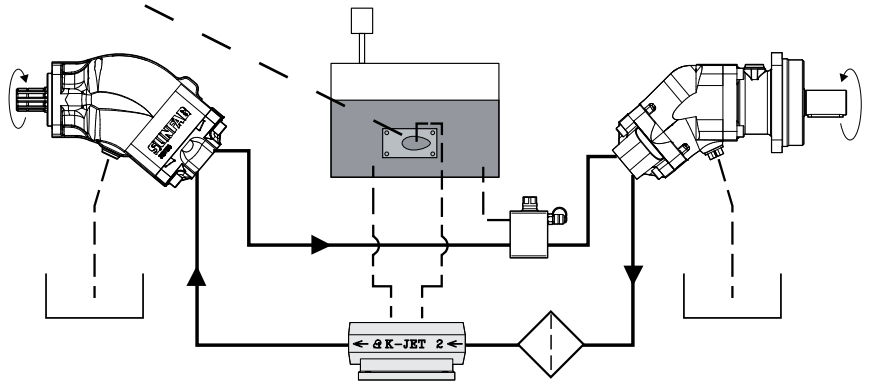
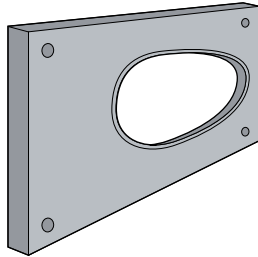
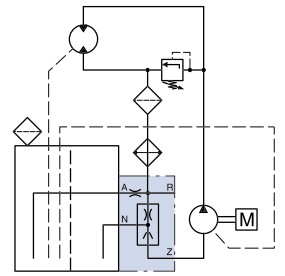

L/min-max

SCM	Injector K-Jet 2/160	91926	60-160	SAP/SCP/SCP ISO
	Injector K-Jet 2/270	91927	100-270	
	Injector K-Jet 2/350	91928	140-380	
	Connection plate Anschlussplatte Anslutningsplatta	91929		Equipment Ausrüstung Utrustning

For detailed information,
see separate Datasheet on
our [website](#).

Ausführliche Beschreibung:
Siehe Datenblatt auf
unserer [Website](#).

För detaljerad information se separat
datablad på vår [hemsida](#).



Speed Sensor
Drehzahlsensor
Varvtalsgivare

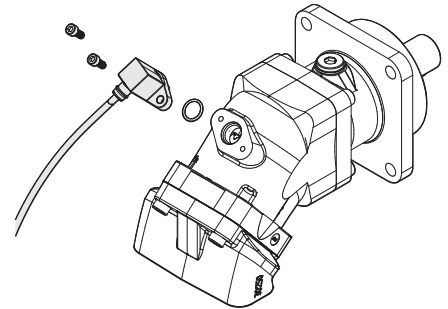
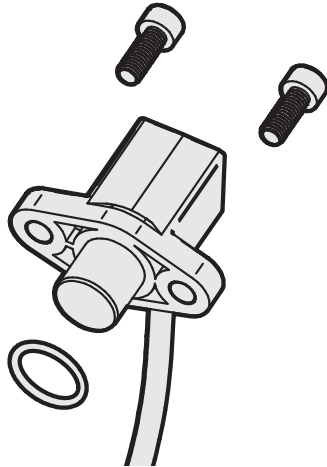

SCM	92133	PNP	Multi-operation system Mehrfunktionssystem Flerfunktionssystem
	92134	NPN	

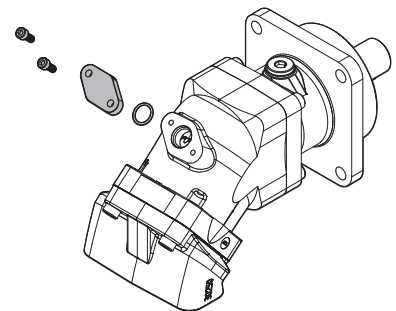
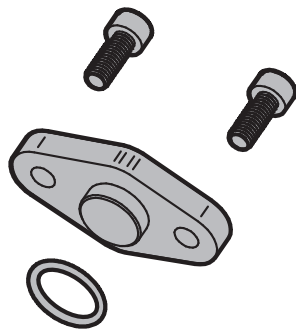

SCM	50865	-	Plug / Plug / Plugg
-----	-------	---	---------------------

For detailed information,
see separate Datasheet on
our [website](#).

Ausführliche Beschreibung:
Siehe Datenblatt auf
unserer [Website](#).

För detaljerad information se separat
datablad på vår [hemsida](#).

Gaskets
Dichtungen
Packningar

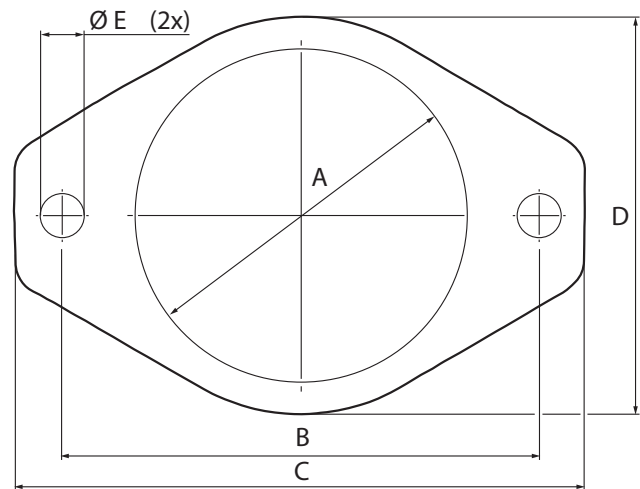
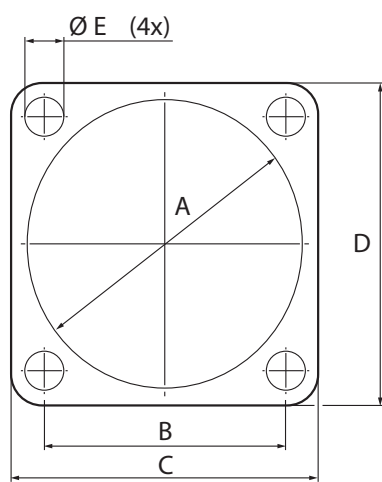

		ØA	B	C	D	ØE
		mm	mm	mm	mm	mm
DIN 4	61077	81	80	106	106	13
SAE-B 4	18244	102	146	114	144	13
SAE-B 2	61178	102	146	175	122	14
SAE-C 4	61177	128	114,5	145,5	114,5	14

3441 GB-DE-SE 1506 Rev 1.0



Stud kit Stiftschrauben Satz Pinnbultsats

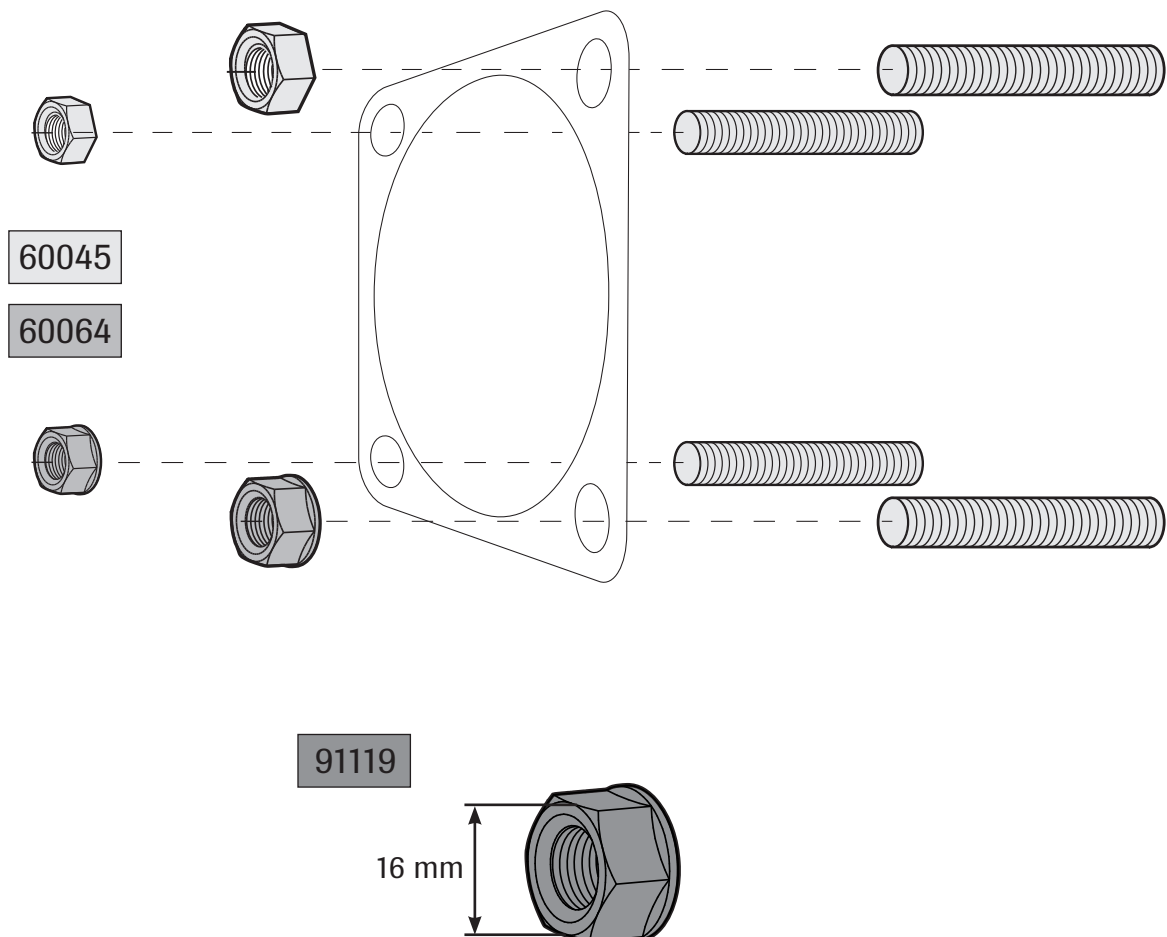

DIN 4 (80x80 mm)	60045	M12x49 (NV19)
	60064	M12x49 Ø 17 (NV16)
—	91119	M12-10-NV16-FZB



Diode Gate
 Dioden-Torschaltung
 Diodgrind

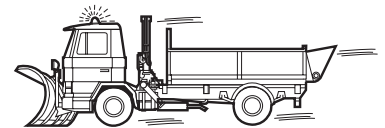
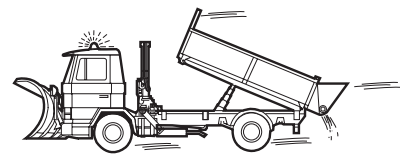
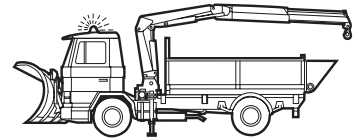
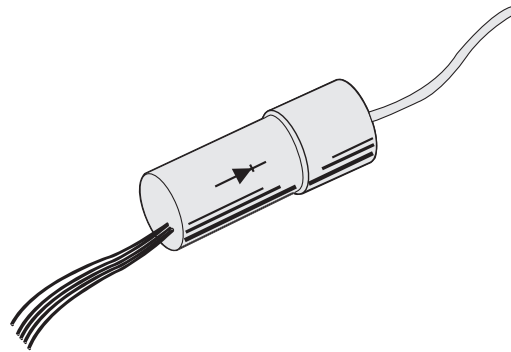
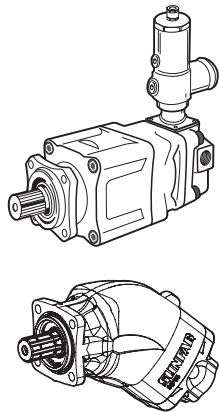

SLPD 20/20-64/32 Savtec
 SAP, SCP, SAPT+By Pass

91362

Multi-operation system
 Mehrfunktionssystem
 Flerfunktionssystem

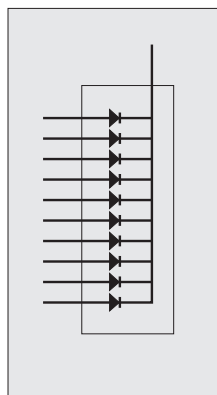

*For detailed information,
 see separate Datasheet on
 our [website](#).*

*Ausführliche Beschreibung:
 Siehe Datenblatt auf
 unserer [Website](#).*

*För detaljerad information se separat
 datablad på vår [hemsida](#).*



NOTES

A series of horizontal dotted lines for taking notes.



NOTES

A series of horizontal dotted lines spanning the width of the page, providing a template for handwritten notes.



Head office
Sunfab Hydraulics AB
Box 1094
Street address: Varvsgatan 2 - 4
SE-824 12 Hudiksvall, Sweden

E-mail: sunfab@sunfab.se
Tel: +46 650 367 00
Fax: +46 650 367 27

www.sunfab.com



Please contact Sunfab for detailed information and maintenance instructions.
Sunfab reserves the right to make changes in design and dimensions without notice. Printing and typesetting errors reserved.

Copyright © by Sunfab Hydraulics AB. All rights reserved.