

MMFS50C

PRODUCT FEATURE SUMMARY

DATE: 17.02.2023

Username: mathias nielsen

MODEL TYPE: MMFS50C

CNSORDERNO (Order number)	MMFS50C
AO (Adjustment Option)	omit: without valve
MF (Mounting Flange)	F: Oval mount, two holes
PT (Port type)	S: Side ports
DC (Displacement code)	50: 50,0 cm ³ /rev [3.05 in ³ /rev]
SE (Shaft Extensions)	C: ø16 straight, Parallel key A5x5x16 DIN6885
P (Ports)	omit: BSPP (ISO 228)
LC (Line to control)	-
VPR (Valve Rated Pressurebar)	-
SFMS (Special Features Measure speed)	omit: no special features
SFGWS (Special Features of gear wheel set)	omit: no special features
SFDR (Special Features - Direction of rotation)	omit: Standard
OP (Option (Paint))	omit: no paint
INFO (Info)	PDF catalog
L (mm)	122.5
L1 (mm)	21

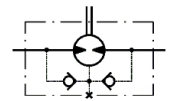

DATA SHEET

Type	
Displacement, cm³/rev [in³/rev]	50[3.05]
Max. Speed, [RPM]	cont.
	400
	Int.*
	500
Max. Torque, daNm [lb-in]	cont.
	4,5 [398]
	Int.*
	5,8 [513]
Max. Output, kW [HP]	cont.
	1,7 [2.48]
	Int.*
	2,1 [2.8]
Max. Pressure Drop, bar [PSI]	cont.
	70 [1015]
	Int.*
	90 [1300]
Max. Oil Flow, lpm [GPM]	cont.
	20 [5.5]
	Int.*
	25 [6.6]

Type	
Max. Inlet Pressure, bar [PSI]	cont.
	140 [2030]
	Int.*
	175 [2540]
	peak**
	225 [3260]
Max. Return Pressure with Drain Line bar [PSI]	cont.
	140 [2030]
	Int.*
	175 [2540]
	peak**
	225 [3260]
Pressure with Unloaded Shaft, bar [PSI]	
	4 [60]
Min Starting Torque, daNm [lb-in]	at max. press. drop cont.
	3,7 [330]
	at max. press. drop Int.*
	4,8 [425]
Min. Speed***, [RPM]	20
Weight, kg [lb]	2,6 [5.73]

* Intermittent operation: the permissible values may occur for max. 10% of every minute.

** Peak load: the permissible values may occur for max. 1% of every minute.

*** For speeds lower than given, consult factory or your regional manager.

- Intermittent speed and intermittent pressure drop must not occur simultaneously.
- Recommended filtration is per ISO cleanliness code 20/16. A nominal filtration of 25 micron or better.
- Recommend using a premium quality, anti-wear type mineral based hydraulic oil HLP(DIN51524) or HM (ISO 6743/4). If using synthetic fluids consult the factory for alternative seal materials.
- Recommended minimum oil viscosity 13 mm²/s [70 SUS] at 50°C [122°F].
- Recommended maximum system operating temperature is 82°C [180°F].
- To assure optimum motor life fill with fluid prior to loading and run at moderate load and speed for 10-15 minutes.

MMFS50C

3d generated view

To see model in 3D you should use Acrobat Reader with enable 3D view

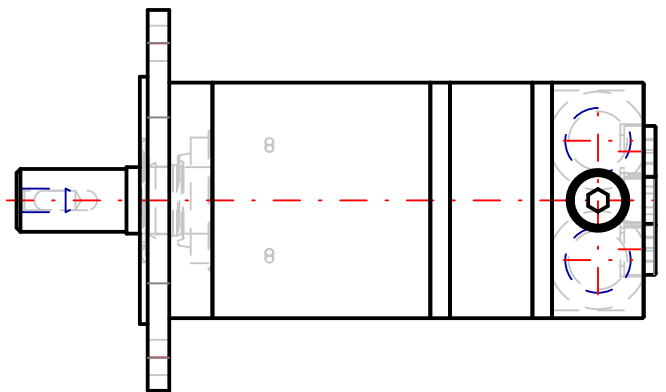
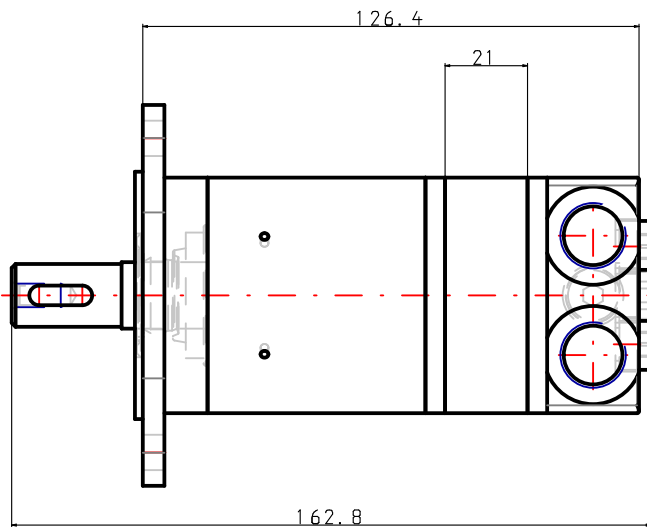
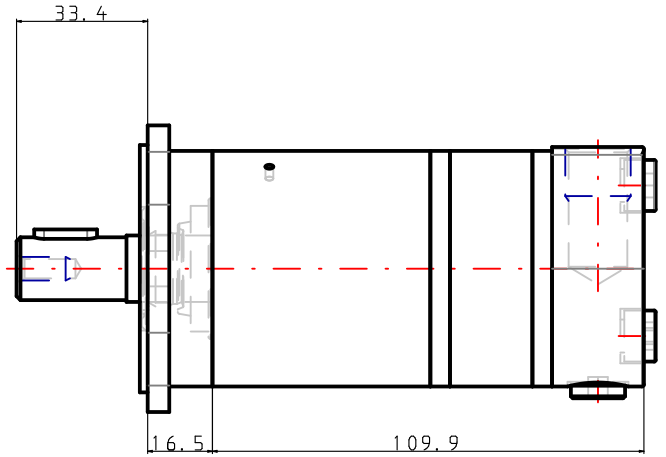
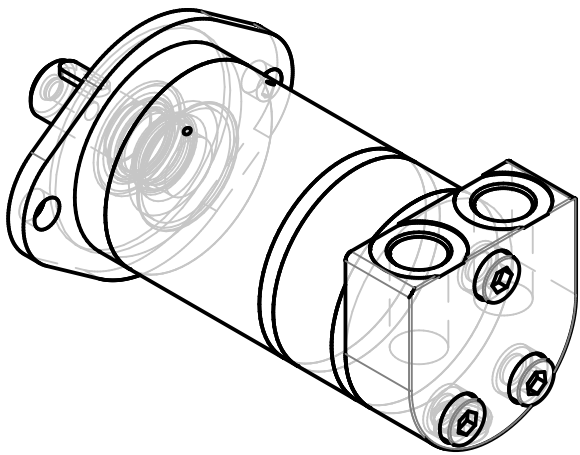

NOTE: Showed dimensions are in nominal, for maximal values see table.
 NOTE: For additional dimensions and information about flange , shaft , endcover , etc. see next page.

L max	LS max
122.5	

Confidential property of M+S Hydraulic, Bulgaria.
 Please note that this drawing is automatically generated based on the selection. In case of possible changes or revisions in the drawing specifications, the selection process should be repeat. M+S is not responsible for any possible errors on the drawings.



MMFS50C

Scale	Sheet	Rev.	Weight
			2,6 [5.73]



Design: M+S Check:

Date 17.02.2023

Standard Rotation
Viewed from Shaft End

Port A Pressurized - CW
Port B Pressurized - CCW

F: Oval mount, two holes

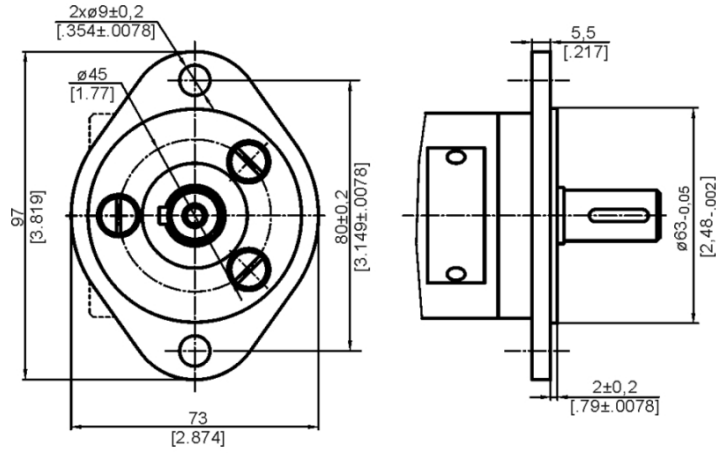

S: Side ports

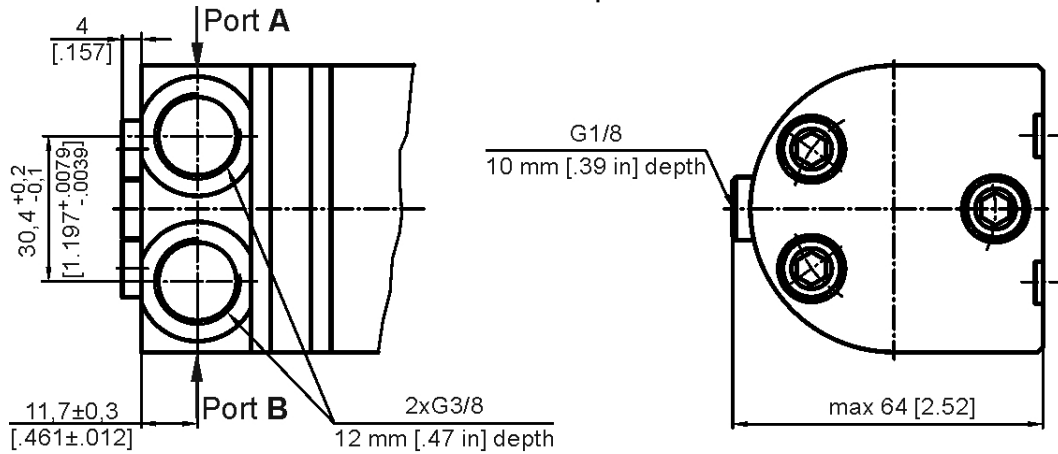

C: $\phi 16$ straight, Parallel key A5x5x16 DIN6885

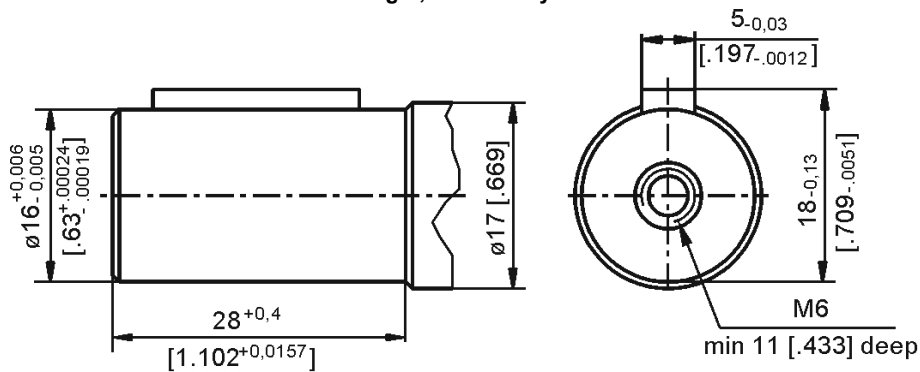

Confidential property of M+S Hydraulic, Bulgaria. Please note that this drawing is automatically generated based on the selection. In case of possible changes or revisions in the drawing specifications, the selection process should be repeat. M+S is not responsible for any possible errors on the drawings.



MMFS50C

Scale	Sheet	Rev.	Weight
Date 17.02.2023			2,6 [$5,73$]

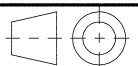

MMFS50C

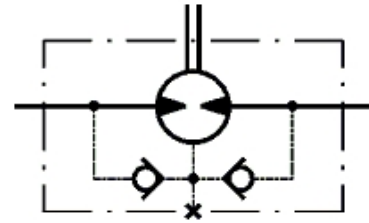

Hydraulic scheme with check valves

FUNCTION DIAGRAMS

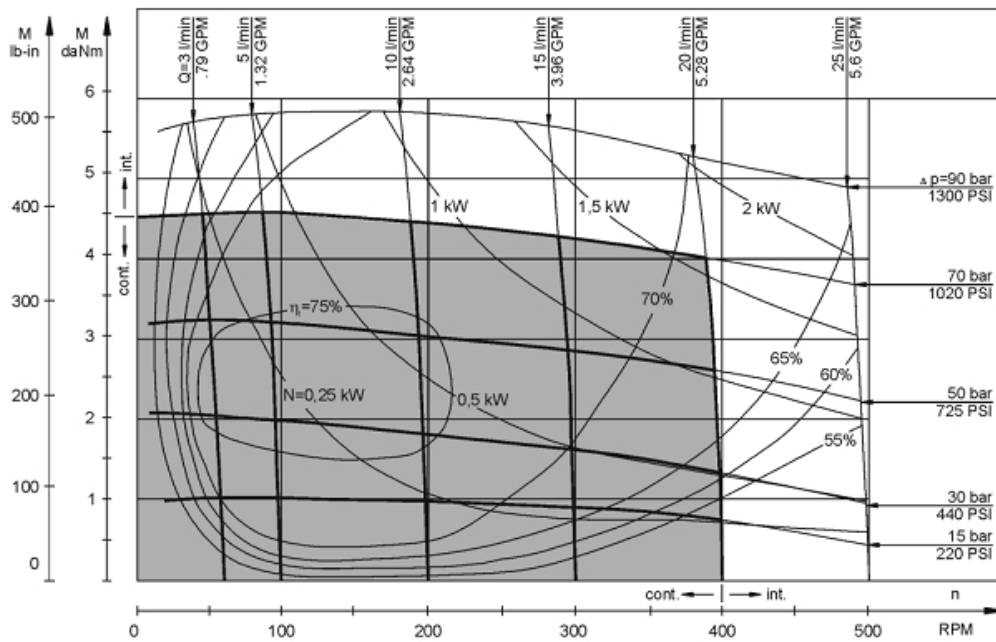

The function diagrams data is for average performance of randomly selected motors at back pressure 5 ± 10 bar [72.5±145 PSI] and oil with viscosity of 32 mm²/s [150 SUS] at 50°C [122°F].

MMFS50C

DATA SHEET

Pressure Losses

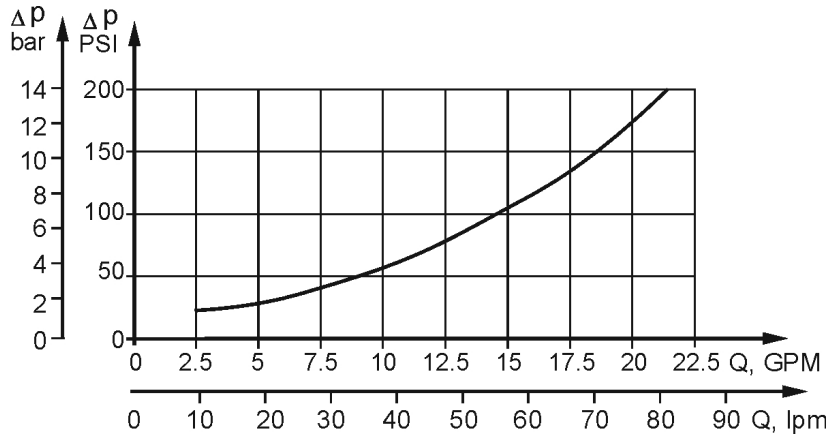

PERMISSIBLE SHAFT LOADS

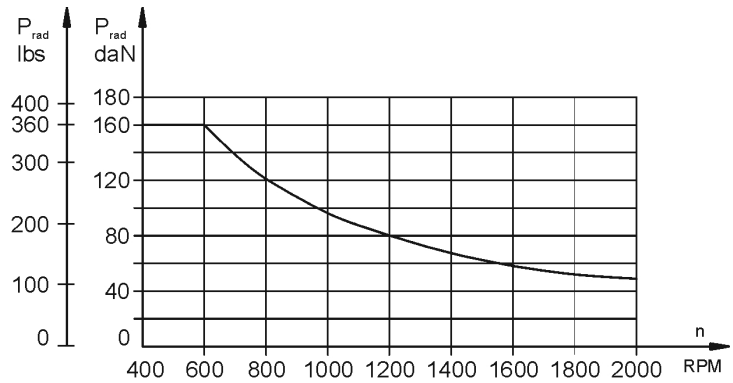
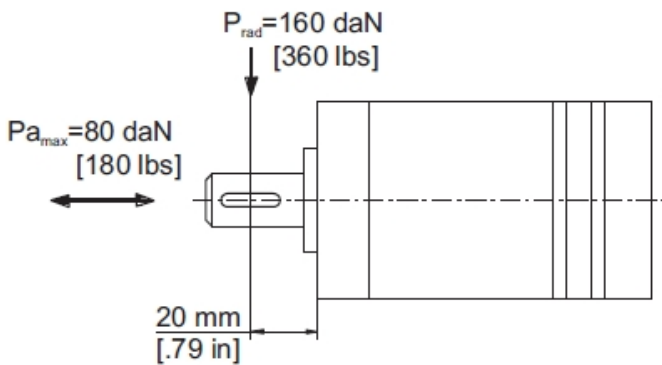

The chart shows the permissible radial load when L=20 mm [.79 in]. If the calculated shaft load exceeds the permissible one, a falexible coupling must be used.

For more detail information about premissible shaft load please check our full catalogue