

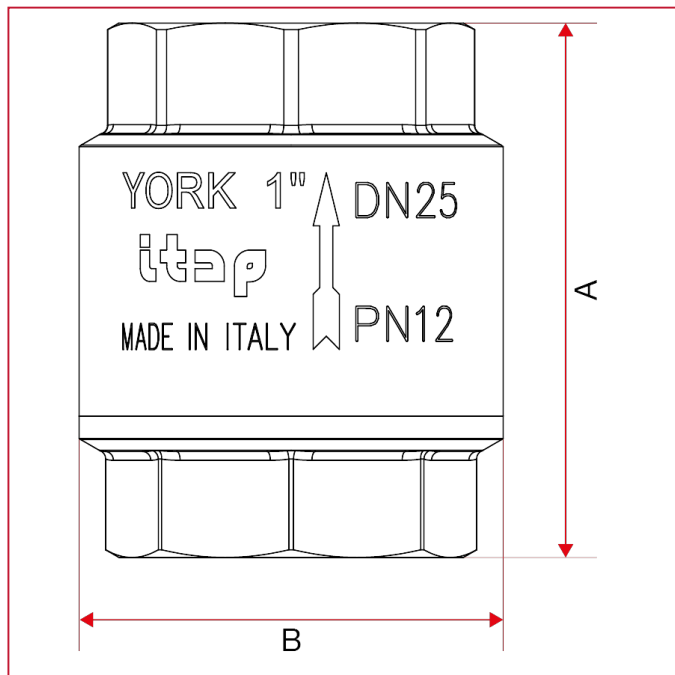

YORK® CHECK AND FOOT VALVES

103 YORK® check valve

OVERALL DIMENSIONS



	3/8"	1/2"	3/4"	1"	1"1/4	1"1/2	2"	2"1/2	3"	4"
DN	10	15	20	25	32	40	50	65	80	100
A	46,5	48	53	60,5	66,5	74	80,5	98	103	118,5
B	35	35	42	48	59,5	70,5	86	103	126	154
Kg/cm ² bar	12	12	12	12	10	10	10	8	8	8
LBS - psi	174	174	174	174	145	145	145	116	116	116



103 YORK® check valve

INSTALLATION

The YORK® check valves are uni-directional; that means they manage the flow in one direction only, which is indicated by the arrow on the body.

The valves are composed by a spring, a little valve and a couple of parts made of brass (body and end-adapter) which contain them and that are assembled but means of thread and a sealed material to obtain their aim.

In order to avoid that the sealed material gets broken and then the valve loses the connection between the body and the end-adapter, it's necessary to avoid to submit the two parts under the influence of a torque.

For the installation normal hydraulic practices must be used, and especially:

- for a proper installation of the valve, near curves and circulation pumps, the valve must be mounted at a distance equal to 10 times the diameter of the pipe.
- ones have to be sure that the two pipes are correctly aligned;
- during the assembling process the installer has to apply its assembling tools at the end that is nearest to the pipe;
- the application of the sealing materials by the fitter (PTFE or hempen cloth) must be limited at the thread zone. An excess should interfere in the ball gasket's closure zone, compromising the tightness;
- in case the fluid transported has got some impurities (dust, too hard water, and so on) it's necessary to remove impurities by or filter them, otherwise they could damage the seal.

DISASSEMBLY

To remove the valve from the pipe line or anyhow before to unscrew the junctions linked to it:

- wear the protective clothing normally required to work with carried fluids;
- Depressurize the line;
- During the disassembling process, apply the key at the end of the valve, the one nearest the pipe.

MAINTENANCE

Verify the valves periodically, in function of their application's field and in function of their work conditions, to be sure that the valves work correctly.

In case of losses of tightening, take note that these can be caused by a deposit of foreign bodies (dirty, calcareous) on the rubber seal.

In order to solve this inconvenient, it's necessary to unmount the valve and remove the foreign body with compressed air tools.



YORK® CHECK AND FOOT VALVES

103 YORK® check valve

LOSS DIAGRAM (With water)

	3/8"	1/2"	3/4"	1"	1"1/4"	1"1/2"	2"	2"1/2"	3"	4"
KV	2,11	4,22	7,92	11,67	22,42	29,39	51,40	69,90	98,49	157,91

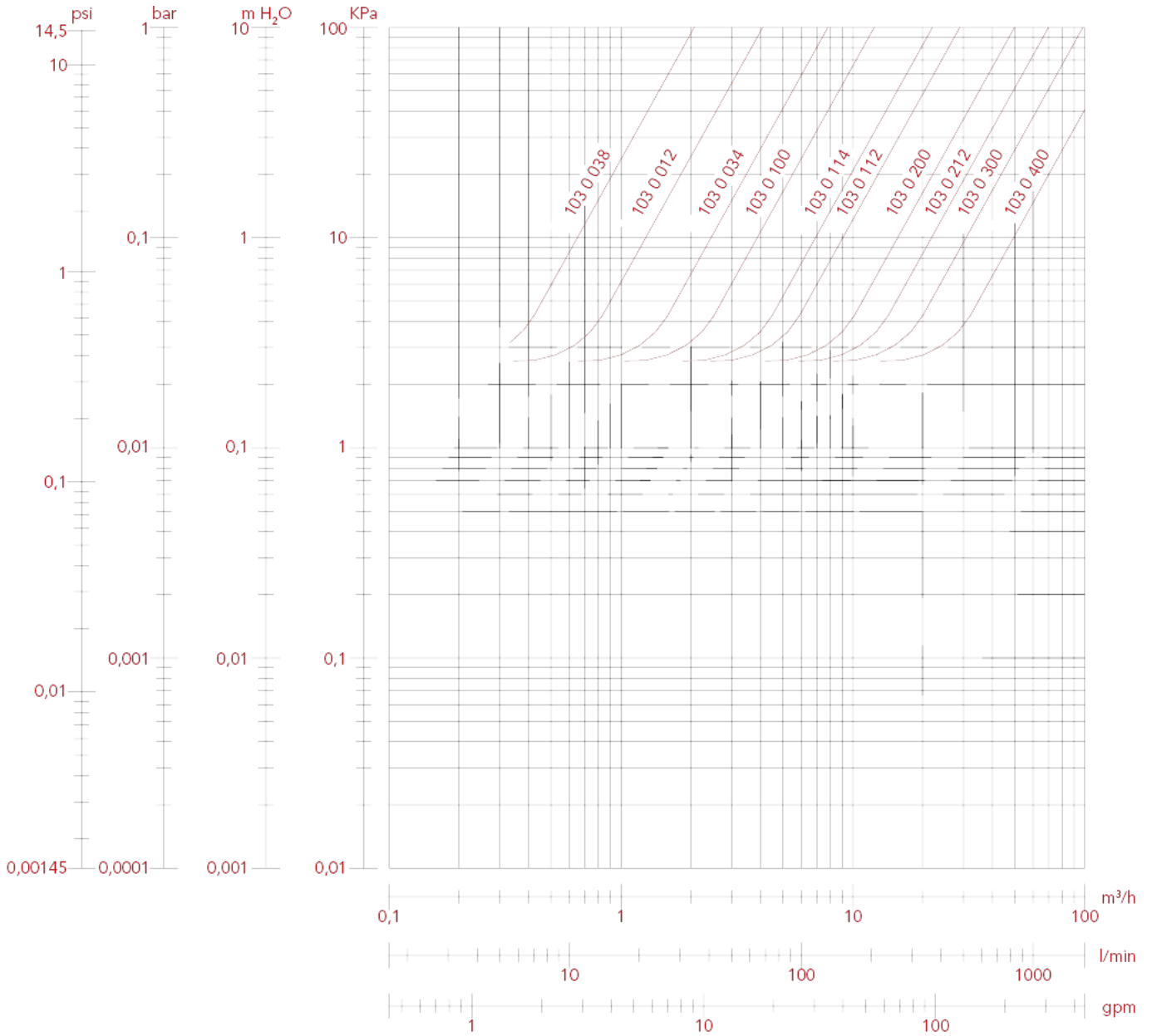



YORK[®] CHECK AND FOOT VALVES

103 YORK[®] check valve

DIAGRAM OF THE MINIMUM PRESSURE NEEDED TO GET THE VALVES OPENING

The opening of the valve is given by the different pressure between the two sides of the seat.

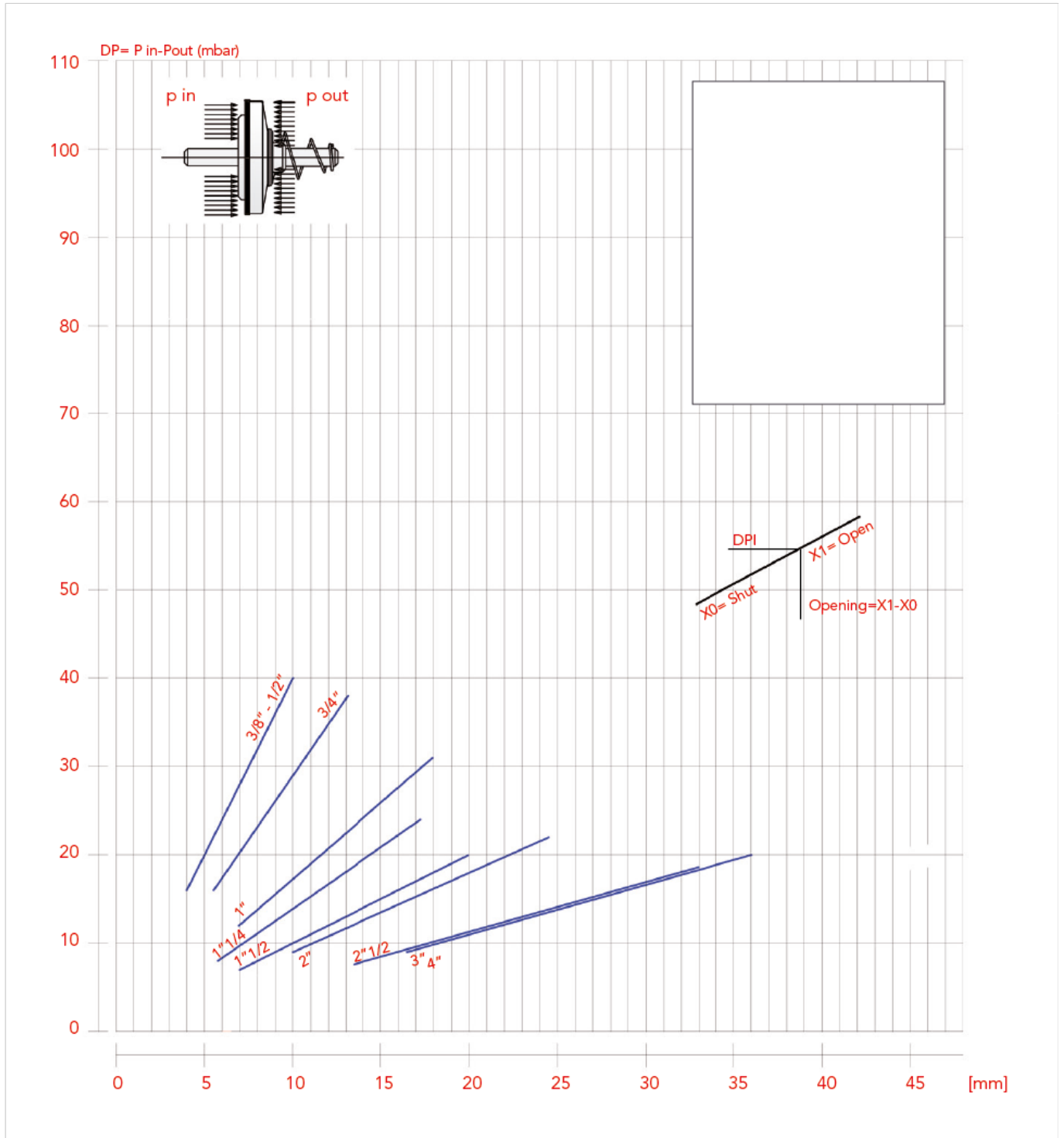



YORK[®] CHECK AND FOOT VALVES

103 YORK[®] check valve

PRESSURE-TEMPERATURE DIAGRAM

The values shown by the dropping lines state the maximum limit of employment of the valves.
The shown values are approximate.

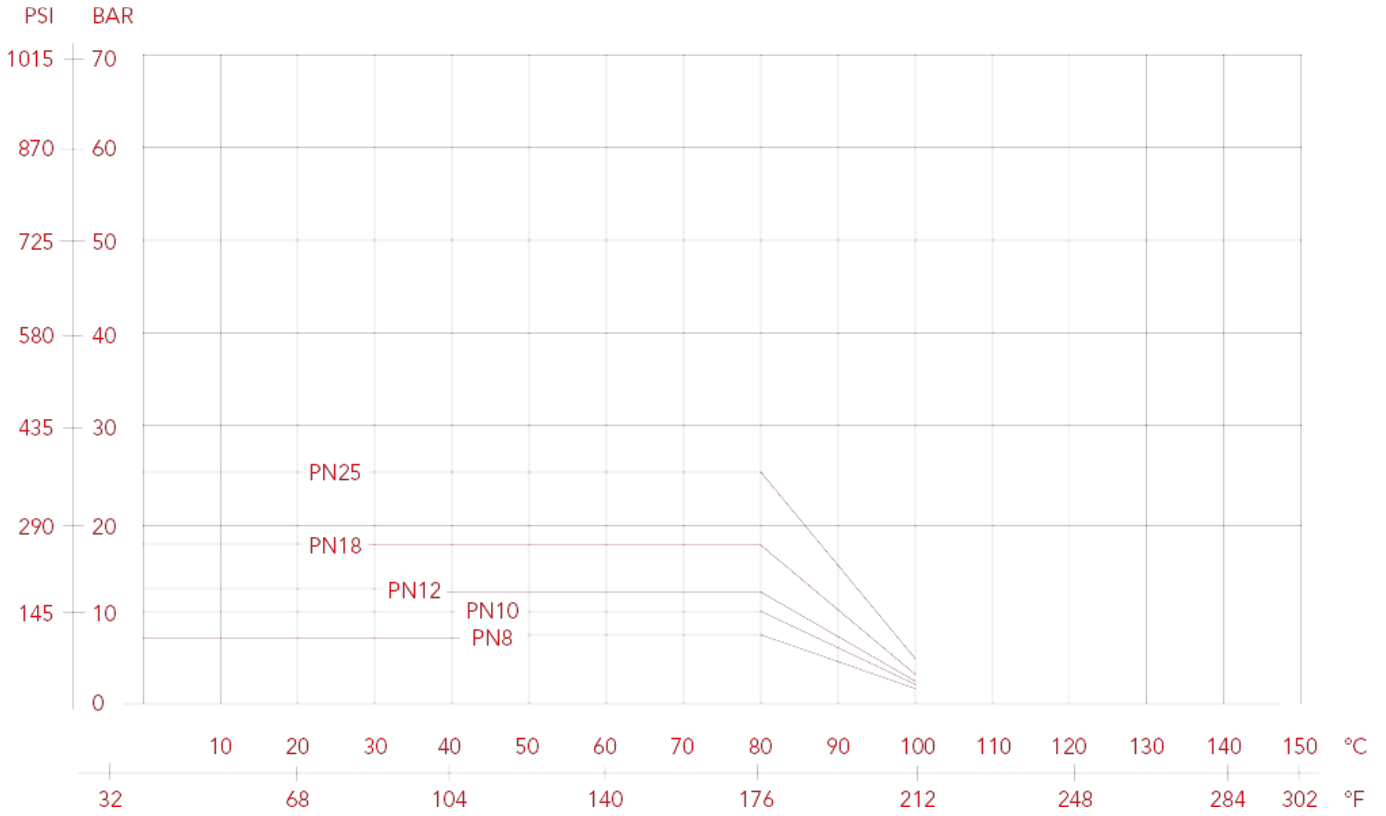



DECLARATION OF CONFORMITY

(According to EN ISO/IEC 17050-1)

The ITAP S.p.A. manufacturer of valves, fittings, manifolds and accessories for thermo-sanitary plants, with head office in via Ruca 19/21 – 25065 Lumezzane S.S. (BS) Italy.

DECLARES

Under its sole responsibility that the YORK® check and foot valves have been built according to industry standards and conform to their technical specifications, respecting the Company Quality System complies with UNI EN ISO 9001.

YORK® check and foot valves are non-controllable check valves, EB type in compliance with European standard EN 1717:2000.

Lumezzane 10 February 2021

Industrial Manager.

ITAP S.p.A.
IL CONSIGLIERE DELEGATO
EZIO PATTI

DECLARATION OF CONFORMITY