

# HK EPM 050 CD

Gerotor motor 050 W25 HD

**HANSA FLEX**

Last updated: 20/08/2024

## Properties

Design	standard variant Type »CD« with high-pressure gasket two hole flange bolt circle 106.4 mm Shaft Ø 25 mm
Connection	Oil port connection: A + B = G 1/2"
Input and return pressure with leak oil line max.	175 bar
Leak oil connection	G 1/4"
Customs tariff number	84122981

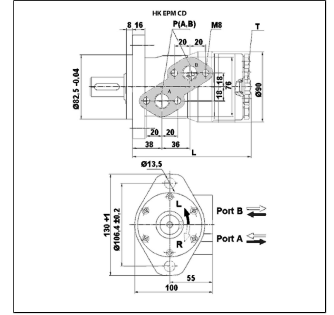

The product image may differ

## Product details

Flow max. (l/min)	60	Displacement (cm <sup>3</sup> )	49.5
Max. speed (r/min)	1,210	Min. speed (r/min)	10
Torque max. (Nm)	94	L (mm)	136
Pressure drop max. (bar)	140	p max. at 0-100 rpm (bar)	150
p max. at 100-300 rpm (bar)	75	p max. at 300-600 rpm (bar)	50
P max. at >600 rpm (bar)	20		

Values for torque and pressure drop apply for continuous operation

pmax: max. pressure on shaft seal (without leakage oil line) respectively pressure in leakage oil line

## Note

Please note the maximum pressure drop (see table)!

## Accessories

HK V0 590	Shock valve
-----------	-------------

## Replacements

HK EP DS	Seal kit for hydraulic planetary motor
----------	--

# HK EPM 080 CD

Gerotor motor 080 W25 HD

**HANSA FLEX**

Last updated: 20/08/2024

## Properties

Design	standard variant Type »CD« with high-pressure gasket two hole flange bolt circle 106.4 mm Shaft Ø 25 mm
Connection	Oil port connection: A + B = G 1/2"
Input and return pressure with leak oil line max.	175 bar
Leak oil connection	G 1/4"
Customs tariff number	84122981

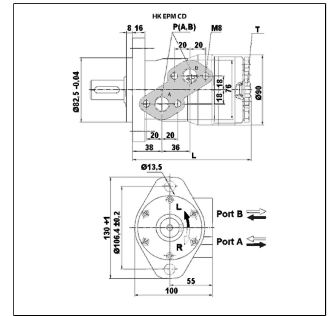

The product image may differ

## Product details

Flow max. (l/min)	60	Displacement (cm <sup>3</sup> )	79.2
Max. speed (r/min)	755	Min. speed (r/min)	10
Torque max. (Nm)	150	L (mm)	140
Pressure drop max. (bar)	140	p max. at 0-100 rpm (bar)	150
p max. at 100-300 rpm (bar)	75	p max. at 300-600 rpm (bar)	50
P max. at >600 rpm (bar)	20		

Values for torque and pressure drop apply for continuous operation

pmax: max. pressure on shaft seal (without leakage oil line) respectively pressure in leakage oil line

## Note

Please note the maximum pressure drop (see table)!

## Accessories

HK V0 590	Shock valve
-----------	-------------

## Replacements

HK EP DS	Seal kit for hydraulic planetary motor
----------	--

### Properties

Design	standard variant Type »CD« with high-pressure gasket two hole flange bolt circle 106.4 mm Shaft Ø 25 mm
Connection	Oil port connection: A + B = G 1/2"
Input and return pressure with leak oil line max.	175 bar
Leak oil connection	G 1/4"
Customs tariff number	84122981

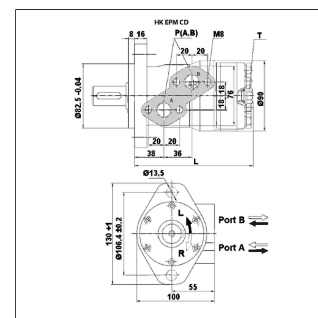

The product image may differ

### Product details

Flow max. (l/min)	60	Displacement (cm <sup>3</sup> )	99
Max. speed (r/min)	605	Min. speed (r/min)	10
Torque max. (Nm)	190	L (mm)	141
Pressure drop max. (bar)	140	p max. at 0-100 rpm (bar)	150
p max. at 100-300 rpm (bar)	75	p max. at 300-600 rpm (bar)	50
P max. at >600 rpm (bar)	20		

Values for torque and pressure drop apply for continuous operation

pmax: max. pressure on shaft seal (without leakage oil line) respectively pressure in leakage oil line

### Note

Please note the maximum pressure drop (see table)!

### Accessories

HK V0 590	Shock valve
-----------	-------------

### Replacements

HK EP DS	Seal kit for hydraulic planetary motor
----------	--

# HK EPM 125 CD

Gerotor motor 125 W25 HD

**HANSA FLEX**

Last updated: 20/08/2024

## Properties

Design	standard variant Type »CD« with high-pressure gasket two hole flange bolt circle 106.4 mm Shaft Ø 25 mm
Connection	Oil port connection: A + B = G 1/2"
Input and return pressure with leak oil line max.	175 bar
Leak oil connection	G 1/4"
Customs tariff number	84122981

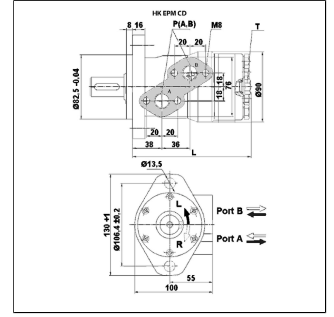

The product image may differ

## Product details

Flow max. (l/min)	60	Displacement (cm <sup>3</sup> )	123.8
Max. speed (r/min)	486	Min. speed (r/min)	10
Torque max. (Nm)	230	L (mm)	145
Pressure drop max. (bar)	140	p max. at 0-100 rpm (bar)	150
p max. at 100-300 rpm (bar)	75	p max. at 300-600 rpm (bar)	50

Values for torque and pressure drop apply for continuous operation

pmax: max. pressure on shaft seal (without leakage oil line) respectively pressure in leakage oil line

## Note

Please note the maximum pressure drop (see table)!

## Accessories

HK V0 590	Shock valve
-----------	-------------

## Replacements

HK EP DS	Seal kit for hydraulic planetary motor
----------	--

# HK EPM 160 CD

Gerotor motor 160 W25 HD

**HANSA FLEX**

Last updated: 20/08/2024

## Properties

Design	standard variant Type »CD« with high-pressure gasket two hole flange bolt circle 106.4 mm Shaft Ø 25 mm
Connection	Oil port connection: A + B = G 1/2"
Input and return pressure with leak oil line max.	175 bar
Leak oil connection	G 1/4"
Customs tariff number	84122981

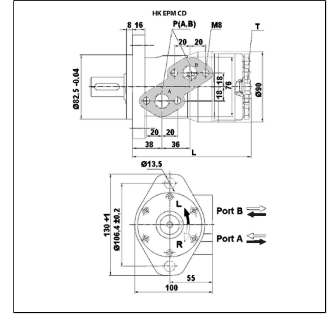

The product image may differ

## Product details

Flow max. (l/min)	60	Displacement (cm <sup>3</sup> )	158.4
Max. speed (r/min)	378	Min. speed (r/min)	10
Torque max. (Nm)	310	L (mm)	150
Pressure drop max. (bar)	140	p max. at 0-100 rpm (bar)	150
p max. at 100-300 rpm (bar)	75	p max. at 300-600 rpm (bar)	50

Values for torque and pressure drop apply for continuous operation

pmax: max. pressure on shaft seal (without leakage oil line) respectively pressure in leakage oil line

## Note

Please note the maximum pressure drop (see table)!

## Accessories

HK V0 590	Shock valve
-----------	-------------

## Replacements

HK EP DS	Seal kit for hydraulic planetary motor
----------	--

# HK EPM 200 CD

Gerotor motor 200 W25 HD

**HANSA FLEX**

Last updated: 20/08/2024

## Properties

Design	standard variant Type »CD« with high-pressure gasket two hole flange bolt circle 106.4 mm Shaft Ø 25 mm
Connection	Oil port connection: A + B = G 1/2"
Input and return pressure with leak oil line max.	175 bar
Leak oil connection	G 1/4"
Customs tariff number	84122981

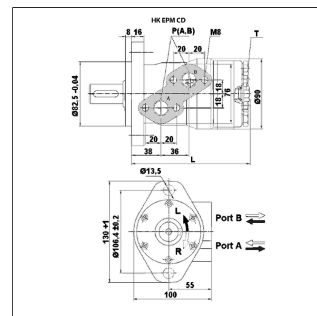

The product image may differ

## Product details

Flow max. (l/min)	60	Displacement (cm <sup>3</sup> )	198
Max. speed (r/min)	303	Min. speed (r/min)	10
Torque max. (Nm)	360	L (mm)	155
Pressure drop max. (bar)	140	p max. at 0-100 rpm (bar)	150
p max. at 100-300 rpm (bar)	75	p max. at 300-600 rpm (bar)	50

Values for torque and pressure drop apply for continuous operation

pmax: max. pressure on shaft seal (without leakage oil line) respectively pressure in leakage oil line

## Note

Please note the maximum pressure drop (see table)!

## Accessories

HK V0 590	Shock valve
-----------	-------------

## Replacements

HK EP DS	Seal kit for hydraulic planetary motor
----------	--

# HK EPM 315 CD

Gerotor motor 315 W25 HD

**HANSA FLEX**

Last updated: 20/08/2024

## Properties

Design	standard variant Type »CD« with high-pressure gasket two hole flange bolt circle 106.4 mm Shaft Ø 25 mm
Connection	Oil port connection: A + B = G 1/2"
Input and return pressure with leak oil line max.	175 bar
Leak oil connection	G 1/4"
Customs tariff number	84122981

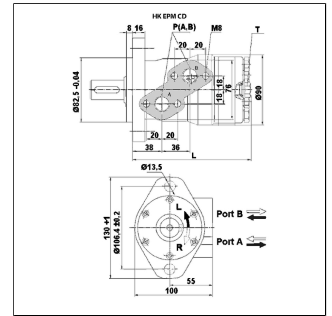

The product image may differ

## Product details

Flow max. (l/min)	60	Displacement (cm <sup>3</sup> )	316.8
Max. speed (r/min)	190	Min. speed (r/min)	10
Torque max. (Nm)	380	L (mm)	171
Pressure drop max. (bar)	90	p max. at 0-100 rpm (bar)	150
p max. at 100-300 rpm (bar)	75		

Values for torque and pressure drop apply for continuous operation

p<sub>max</sub>: max. pressure on shaft seal (without leakage oil line) respectively pressure in leakage oil line

## Note

Please note the maximum pressure drop (see table)!

## Accessories

HK V0 590	Shock valve
-----------	-------------

## Replacements

HK EP DS	Seal kit for hydraulic planetary motor
----------	--

# HK EPM 400 CD

Gerotor motor 400 W25 HD

**HANSA FLEX**

Last updated: 16/08/2024

## Properties

Design	standard variant Type »CD« with high-pressure gasket two hole flange bolt circle 106.4 mm Shaft $\varnothing$ 25 mm
Connection	Oil port connection: A + B = G 1/2"
Input and return pressure with leak oil line max.	175 bar
Leak oil connection	G 1/4"
Customs tariff number	84122981

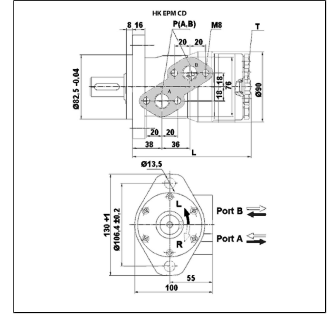

The product image may differ

## Product details

Flow max. (l/min)	60	Displacement (cm <sup>3</sup> )	396
Max. speed (r/min)	150	Min. speed (r/min)	10
Torque max. (Nm)	380	L (mm)	182
Pressure drop max. (bar)	70	p max. at 0-100 rpm (bar)	150
p max. at 100-300 rpm (bar)	75		

Values for torque and pressure drop apply for continuous operation

pmax: max. pressure on shaft seal (without leakage oil line) respectively pressure in leakage oil line

## Note

Please note the maximum pressure drop (see table)!

## Accessories

HK V0 590	Shock valve
-----------	-------------

## Replacements

HK EP DS	Seal kit for hydraulic planetary motor
----------	--