



TECHNICAL CATALOGUE

GATE VALVES



> THE COMPANY

ITAP SpA, founded in Lumezzane (Brescia) in 1972, is currently one of the leading production companies in Italy of **valves, fittings and distribution manifolds** for plumbing and heating systems.

Thanks to fully automated production processes, with 87 transfer machines and 70 assembly lines, we are able to produce 400,000 pieces per day.

Our innate pursuit for innovation and observance of technical regulations is supported by the company certification ISO 9001. The company has always considered its focus on quality as the main tool to obtain significant business results: today ITAP SpA is proud to offer products bearing the approval of numerous international certifying bodies.

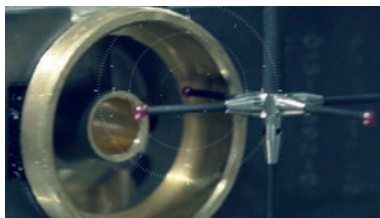
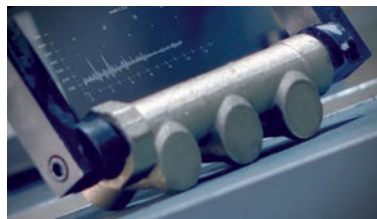
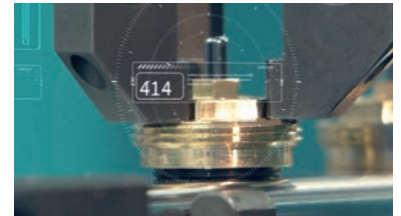
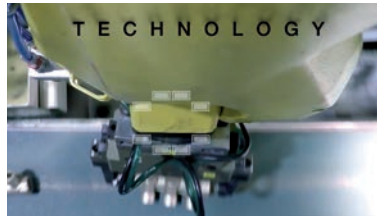

> ITAP products have obtained approvals by more than 30 certification bodies from all over the world.





GATE VALVES

156 Brass gate valve PN16

Suitable for domestic water services, heating, air-conditioning plants and compressed air systems.

GATE VALVE



SIZE	PRESSURE	CODE	PACKING
1/2" (DN 15)	16bar/232psi	1560012	12/72
3/4" (DN 20)	16bar/232psi	1560034	10/60
1" (DN 25)	16bar/232psi	1560100	5/35
1"1/4 (DN 32)	16bar/232psi	1560114	4/24
1"1/2 (DN 40)	16bar/232psi	1560112	2/14
2" (DN 50)	16bar/232psi	1560200	2/14
2"1/2 (DN 65)	16bar/232psi	1560212	1/8
3" (DN 80)	16bar/232psi	1560300	1/8
4" (DN 100)	16bar/232psi	1560400	1/2

CERTIFICATIONS



TECHNICAL SPECIFICATIONS

Female/female threads.

Handwheel in aluminium.

Body in brass.

Minimum and maximum working temperatures: 0°C, 150°C in absence of steam.

Threads: ISO 228 (equivalent to DIN EN ISO 228 and BS EN ISO 228).

Available also with NPT thread in the sizes 2"1/2, 3" and 4".



GATE VALVES

OVERALL DIMENSIONS

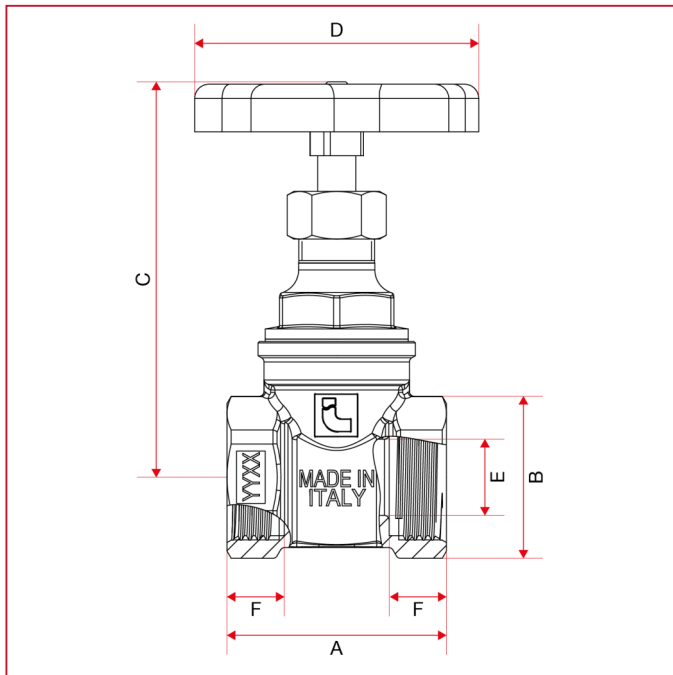

	1/2"	3/4"	1"	1"1/4	1"1/2	2"	2"1/2	3"	4"
DN	15	20	25	32	40	50	65	80	100
A	42	46	50	55	60	67	78	83	100
B	28	34	40,3	51,5	57	71,5	90	102,7	132,4
C	72,5	82,5	96	104,1	116,6	138,7	180,5	201,5	237,8
D	50	60	60	70	70	80	100	100	120
E	13	16	23	28	33	45	59	68	85
F	11,5	12	14	16	17	18	19	22	25,5
Kg/cm ² bar	16	16	16	16	16	16	16	16	16
LBS - psi	232	232	232	232	232	232	232	232	232



GATE VALVES

MATERIALS sizes 1/2" through 2"

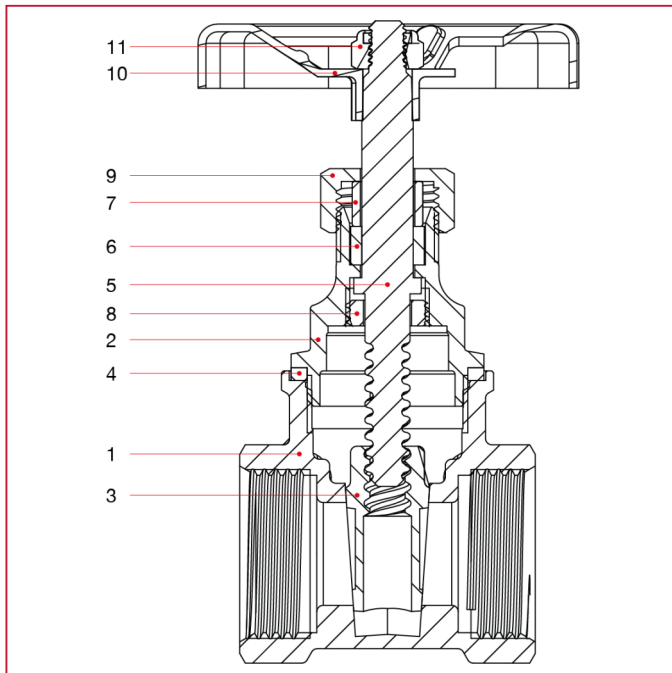

POS.	DESCRIPTION	N.	MATERIAL
1	Body	1	Brass CW617N
2	Bonnet	1	Brass CW617N
3	Disk	1	Brass CW617N
4	Washer	1	NA1002
5	Stem	1	Brass CW617N
6	Stem washer	1	FE1000
7	Packing-gland	1	Brass CW617N
8	Stem stopper	1	Brass CW617N
9	Cap	1	Brass CW617N
10	Handwheel	1	Varnished aluminium EN AB-46100
11	Self-locking nut	1	Zinc-plated steel CL8



GATE VALVES

MATERIALS sizes 2"1/2 through 4"

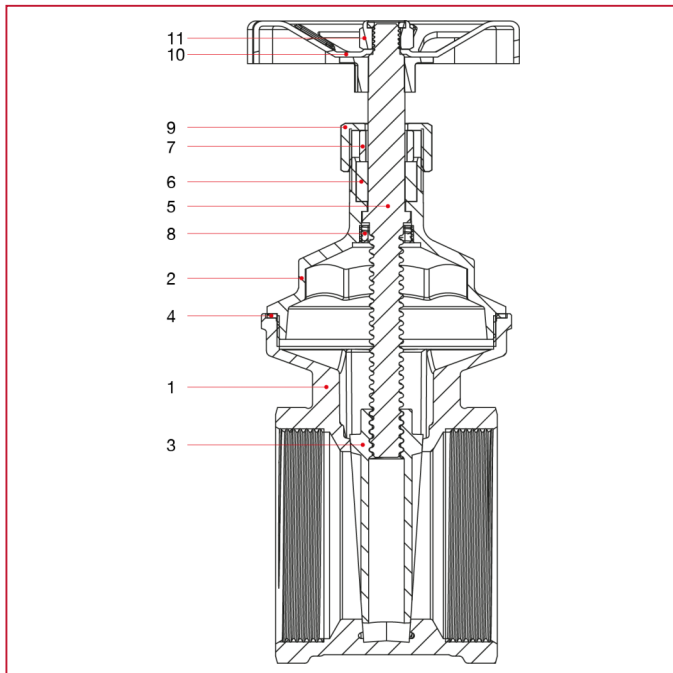

POS.	DESCRIPTION	N.	MATERIAL
1	Body	1	Brass CC754S
2	Bonnet	1	Brass CW617N
3	Disk	1	Brass CW617N
4	Washer	1	NA1002
5	Stem	1	Brass CW617N
6	Stem washer	1	FE1000
7	Packing-gland	1	Brass CW617N
8	Stem stopper	1	Brass CW617N
9	Cap	1	Brass CW617N
10	Handwheel	1	Varnished aluminium EN AB-46100
11	Self-locking nut	1	Zinc-plated steel CL8



GATE VALVES

LOSS DIAGRAM (With water)

	1/2"	3/4"	1"	1"1/4"	1"1/2"	2"	2"1/2"	3"	4"
KV	12	29,4	51	69	138	201	375	864	1680

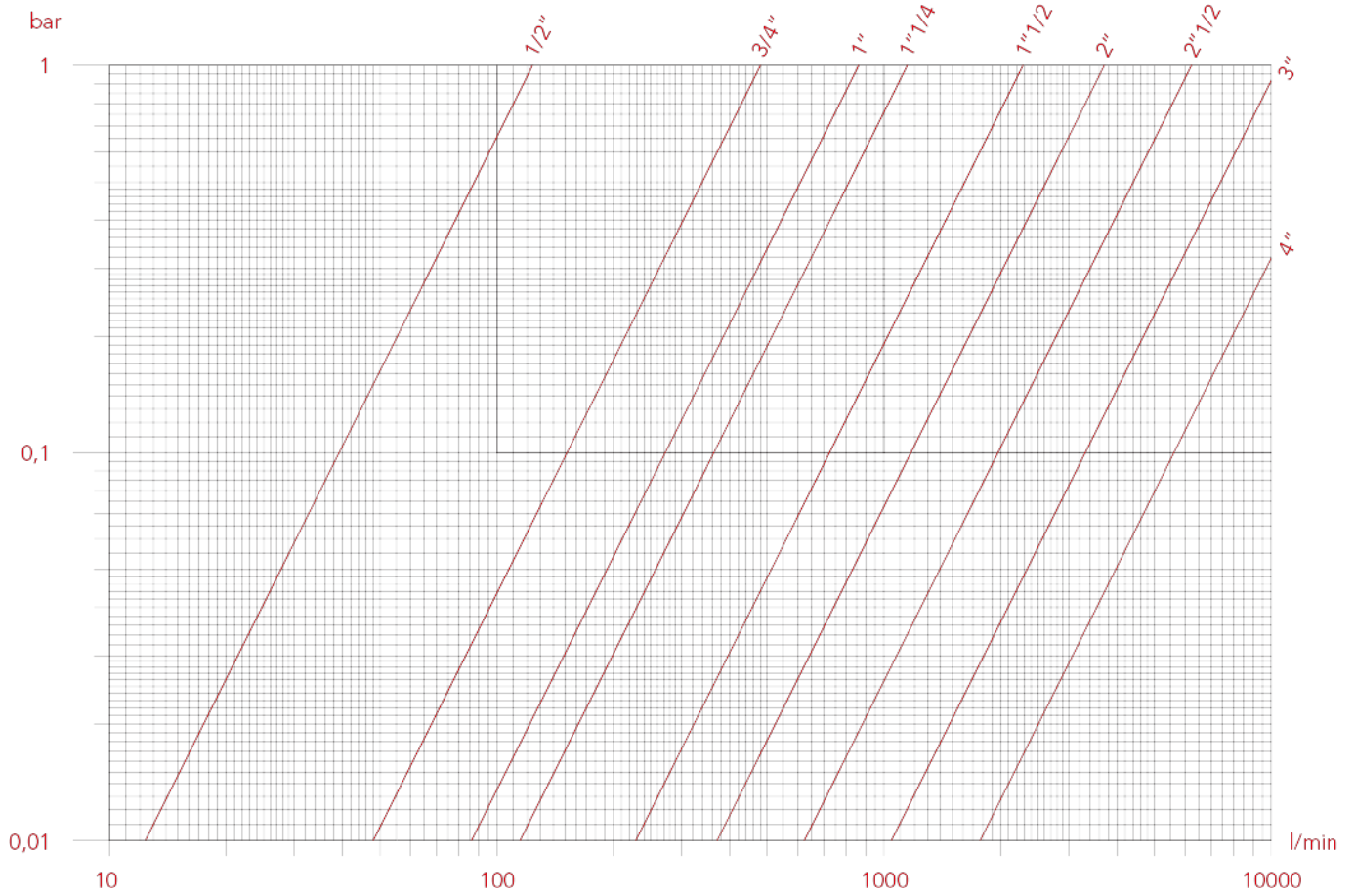



GATE VALVES

PRESSURE-TEMPERATURE DIAGRAM

The values shown by the dropping lines state the maximum limit of employment of the valves.
The shown values are approximate.

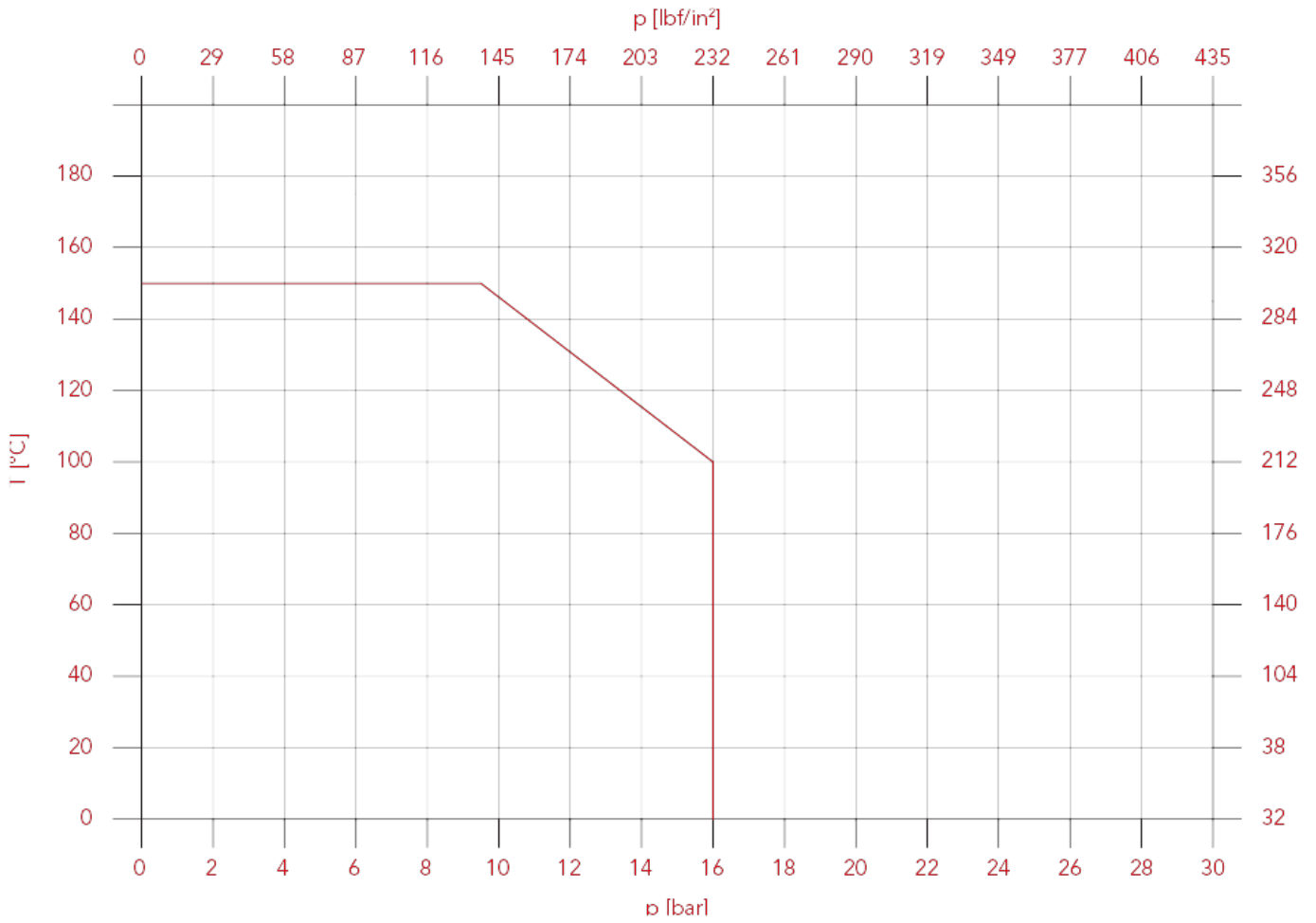



GATE VALVES

VOLA Handwheel for gate valve art. 156



VOL156

SIZE	CODE	PACKING	STRAINER
050	VOLA050	1/150	1/2"
060	VOLA060	1/150	3/4"
060	VOLA060	1/150	1"
070	VOLA070	1/150	1"1/4
070	VOLA070	1/150	1"1/2
080	VOLA080	1/150	2"
100	VOLA100	1/100	2"1/2
100	VOLA100	1/100	3"
120	VOLA120	1/100	4"

TECHNICAL SPECIFICATIONS

Handwheel made of epoxy painted aluminium.

Handwheel made of epoxy painted aluminium.

OVERALL DIMENSIONS

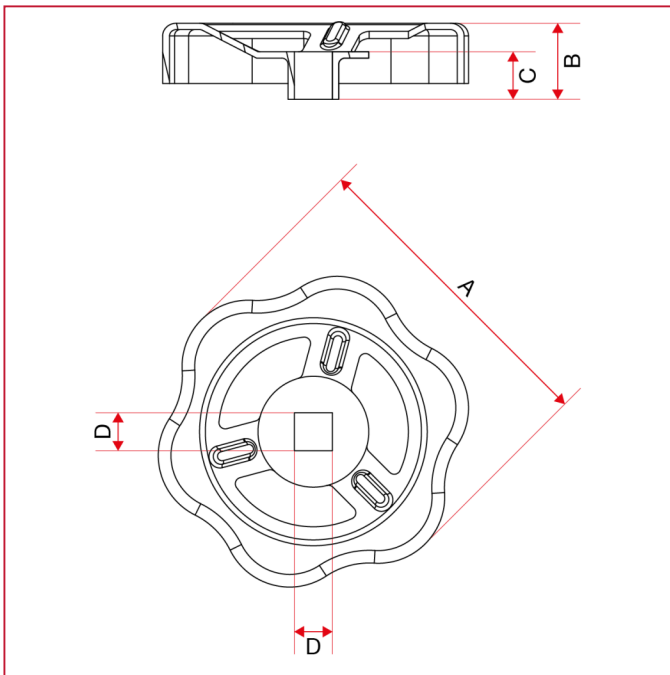

VOL156

	050	060	060	070	070	080	100	100	120
A	50	60	60	70	70	80	100	100	120
B	12	15	15	17,6	17,6	19	25	25	26
C	7,5	8	8	10,6	10,6	10,6	15	15	15
D	6	7	7	7	7	8	11	11	12



GATE VALVES

MATERIALS

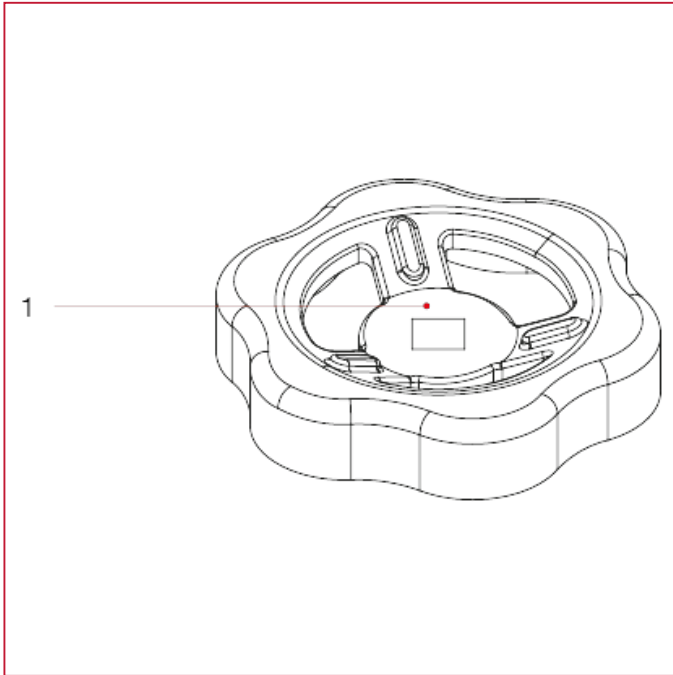

POS.	DESCRIPTION	N.	MATERIAL
1	Handwheel	1	Varnished aluminium EN AB-46100



ITAP S.p.A.
Via Ruca 19
25065 Lumezzane
Brescia (ITALY)
Tel 030 8927011
Fax 030 8921990
www.itap.it - info@itap.it

We reserve the right to make improvements and changes to the products described herein and to the relative technical data, at any time and without forewarning.

rev. 20221108