

ORLANDO

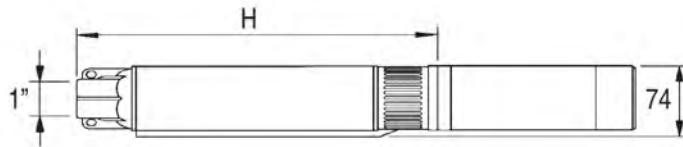

Type	Motore Motor Moteur		Q	Portata - Capacity - Debit							Dimensioni e Pesì Dimension and Weight Dimension et Masses	
	kw	HP		m³/h	0.3	0.6	0.9	1.2	1.8	2.4	2.7	H/mm
			L/min.	5	10	15	20	30	40	45		
PS CO 30 3 15	0.33	0.50	PREVALENZA m TOTAL HEAD m HAUTEUR D'ELEVATION m	46	42	39	36	28	15	7	580	3.3
PS CO 30 3 23	0.55	0.75		70	66	61	55	43	24	13	780	4.4
PS CO 30 3 30	0.75	1		92	86	80	73	57	33	17	1000	5.6
PS CO 30 3 45	1.1	1.5		128	119	112	103	75	47	28	1380	7.6

Description

Submersible multistage centrifugal pumps for 3" wells, particularly suitable for water rising and distribution installations.

Applications

Water plants and systems for residential and industrial use, for continuous or intermittent duty operation. Pressurizing system. Irrigation plants.

Design features

Motor coupling flange and discharge head are made in brass.
 Incorporated non-return check valve.
 Impellers and diffusers in Noryl and diffusers in self-lubricating Polyacetal.
 Shell, pump shaft, coupling, cable shield, suction screen and all screws are in stainless steel.
 Max ø pump 74 mm.

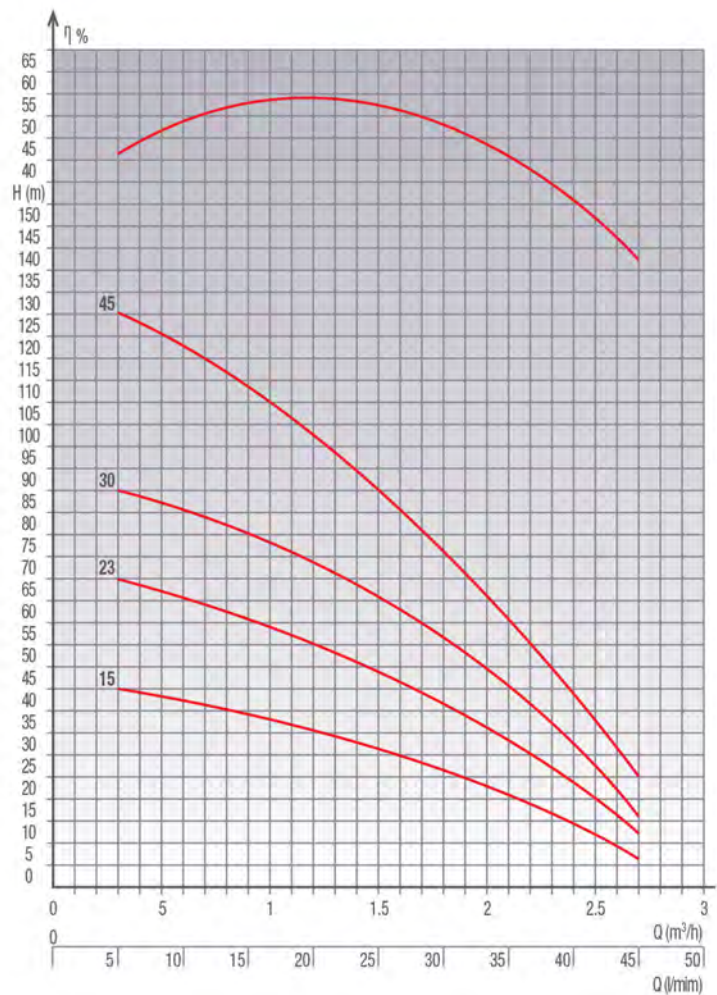

1



Bocca di mandata in ottone o acciaio inox.
Brass or stainless steel discharge head.
Pecce de refoulement en laitfon ou en acier inox.

2



Valvola di non-ritorno incorporata sulla testata.
Discharge head non return valve.
Clapet anti-retour incorporé.

3



Bronzina superiore in gomma antisabbia.
Upper bush made in anti-sand rubber.
Palier superieur en caoutchouc anti sable.

4



Giranti in Noryl e diffusori in poliacetalico autolubrificante.
Impellers in Noryl and diffusers in self-lubricating polyacetal.
Roues en Noryl et diffuseurs en polyacetal auto-lubrifiant.

5



Camicia in acciaio inox.
Stainless steel shell.
Chemise en acier inox.

6



Filtro in acciaio inox.
Stainless steel strainer.
Crepine en acier inox.

7



Flangia d'accoppiamento in ottone o acciaio inox.
Brass or stainless steel bracket to couple to the motor.
Bride d'accouplement au moteur en laitfon ou en acier inox.

1

2

3

4

5

6

7





OPERATING CONDITIONS:

- Max ambient temperature (Liquid): 30°C
- Sand content max: 50gr/m³

PUMPED LIQUIDS: clean, thin, free from solid or abrasive substances, compatible with pump components and materials.

APPLICATIONS: Water supply from deep wells - sprinkler systems for agricultural irrigation - Civil and industrial applications - Fire fighting systems - Drainage and dewatering in mines.

AISI 304

PV 4X SP...:

4" STAINLESS STEEL SUBMERSIBLE PUMPS *SP* SERIE

Basic Features:

- Non polluting, corrosion resistant, stainless steel construction inside and outside
- The smooth safety hook will prevent the rope from abating
- The built-in jam free stainless steel check valve can prevent backflow of water in the pipe from affecting the pump performance when the motor is not operating.
- Precision stainless steel intermediate chamber can help maintain optimum performance even when water pressure is greatest.
- The high performance, high efficiency stainless steel impeller is one of the special features of this product. It is incomparably superior to ordinary plastic or brass impellers in terms of abrasion resistance and service life.

50HZ

CODE	STAGES	Kw	Q= Capacity																											Pump	
			l/min	5	10	15	20	25	30	35	40	45	50	60	70	80	90	100	120	140	160	180	200	250	300	Length (mm)	Weight (kg)				
			m ³ /h	0,3	0,6	0,9	1,2	1,5	1,8	2,1	2,4	2,7	3,0	3,6	4,2	4,8	5,4	6,0	7,2	8,4	9,6	10,8	12	15	18						
			H= Total Head in meters																												
PV SP-0509 4X	9	0.37	52	48	45	36	27	14																				343	3.2		
PV SP-0514 4X	14	0.37	82	76	70	56	41	21																				448	4.2		
PV SP-0518 4X	18	0.55	104	99	88	72	52	27																				542	5.0		
PV SP-0521 4X	21	0.55	121	112	101	81	58	36																				595	5.6		
PV SP-0528 4X	28	0.75	162	153	138	111	73	42																				742	7.0		
PV SP-0536 4X	36	1,1	207	195	171	139	93	50																				945	9.1		
PV SP-0542 4X	42	1,1	243	230	202	160	112	62																				1071	10.4		
PV SP-1009 4X	9	0.37	53			50	47	42	38	33	26																	343	3.1		
PV SP-1013 4X	13	0.55	77			71	68	61	56	48	38																	427	4.0		
PV SP-1018 4X	18	0.75	106			98	92	84	77	66	51																	532	4.9		
PV SP-1023 4X	23	1,1	136			124	118	108	98	84	67																	637	6.0		
PV SP-1028 4X	28	1,5	166			155	146	134	120	103	82																	742	6.8		
PV SP-1033 4X	33	1,5	195			181	171	157	141	120	97																	847	7.6		
PV SP-1040 4X	40	2,2	236			218	205	190	170	142	119																	1029	9,8		
PV SP-1048 4X	48	2,2	282			258	241	221	199	171	137																	1197	11.1		
PV SP-1806 4X	6	0.37	38				34	32	31	30	29	27	22	17														280	2.5		
PV SP-1809 4X	9	0.55	58				54	52	49	48	47	43	36	25														343	3.1		
PV SP-1812 4X	12	0.75	78				67	65	62	59	56	52	42	28														406	3.7		
PV SP-1815 4X	15	1,1	97				84	81	78	74	71	67	52	38														469	4.4		
PV SP-1818 4X	18	1,1	117				101	98	93	89	83	78	64	42														532	4,9		
PV SP-1822 4X	22	1,5	143				123	120	115	110	103	96	77	52														616	5.7		
PV SP-1825 4X	25	1,5	162				140	134	128	121	113	106	86	58														679	6.2		
PV SP-1829 4X	29	2,2	188				162	155	149	142	133	122	98	67														763	7.1		
PV SP-1833 4X	33	2,2	212				180	173	168	160	150	138	109	73														847	7.8		
PV SP-1845 4X	45	3,0	292				250	243	233	223	209	195	153	107														1134	10,5		
PV SP-1852 4X	52	4,0	335				285	276	265	252	239	222	180	123														1281	12.2		
PV SP-2504 4X	4	0.37	25					22	21	20	20	19	18	17	16	14	12											238	2.3		
PV SP-2506 4X	6	0.55	38					34	33	32	31	30	28	26	24	21	17											280	2.8		
PV SP-2508 4X	8	0.75	57					44	43	42	41	40	38	35	32	28	22											322	3.0		
PV SP-2512 4X	12	1,1	75					68	66	65	64	63	58	53	49	42	36											406	3.6		
PV SP-2517 4X	17	1,5	106					95	92	90	87	85	79	73	67	58	50											511	4.6		
PV SP-2521 4X	21	2,2	131					117	114	110	107	103	98	90	82	72	62											595	5.5		
PV SP-2525 4X	25	2,2	156					140	136	131	129	127	118	110	100	90	74											679	6.2		
PV SP-2533 4X	33	3,0	206					182	178	173	170	165	155	142	130	115	98											847	7.6		
PV SP-2544 4X	44	4,0	275					244	239	232	226	221	208	191	174	155	130											1098	10.3		
PV SP-4005 4X	5	0.75	30						26	26	25	25	24	24	23	23	22	19	15	10								407	4,3		
PV SP-4007 4X	7	1,1	41						36	35	34	34	33	33	32	32	29	25	20	15								491	5.3		
PV SP-4010 4X	10	1,5	58						52	52	51	51	50	50	49	49	46	40	34	27								617	6.8		
PV SP-4012 4X	12	2,2	69						63	62	61	60	60	59	58	57	52	49	41	32								701	7.8		
PV SP-4015 4X	15	2,2	86						79	78	77	76	75	73	72	70	66	60	50	40								827	9.2		
PV SP-4018 4X	18	3,0	103						91	90	89	88	87	85	83	81	77	70	60	48								953	10.5		
PV SP-4021 4X	21	4,0	121						111	110	108	106	104	102	100	98	91	82	71	54								1079	12.4		
PV SP-4025 4X	25	4,0	144						131	130	128	126	122	119	116	113	107	97	81	61								1247	15.5		
PV SP-4030 4X	30	5,5	173						155	153	151	149	147	143	139	136	127	114	97	74								1457	17.2		
PV SP-4037 4X	37	5,5	213						192	190	188	184	180	175	170	165	154	139	118	92								1751	26.2		
PV SP-7005 4X	5	1,5	32													29	28	27	26	25	23	19	13				506	5.3			
PV SP-7007 4X	7	2,2	45													40	39	37	36	35	32	26	18			636	6.6				
PV SP-7010 4X	10	3,0	65													58	56	54	52	50	46	38	26	831		831	8.7				
PV SP-7013 4X	13	4,0	85													75	72	70	67	65	60	49	34	1026		1026	10.7				
PV SP-7018 4X	18	5,5	117													104	100	97	93	90	83	68	46	1351		1351	14.1				
PV SP-7025 4X	25	7,5	163													145	140	135	130	125	115	95	65	1806		1806	18.9				

PUMPS OUTLET: :SP-05 SP-10 SP-18 1-1/4", SP-25 1-1/2" SP-40 SP-70 2"

Ø Pumps : 98mm

All these models are available



ORLANDO srl

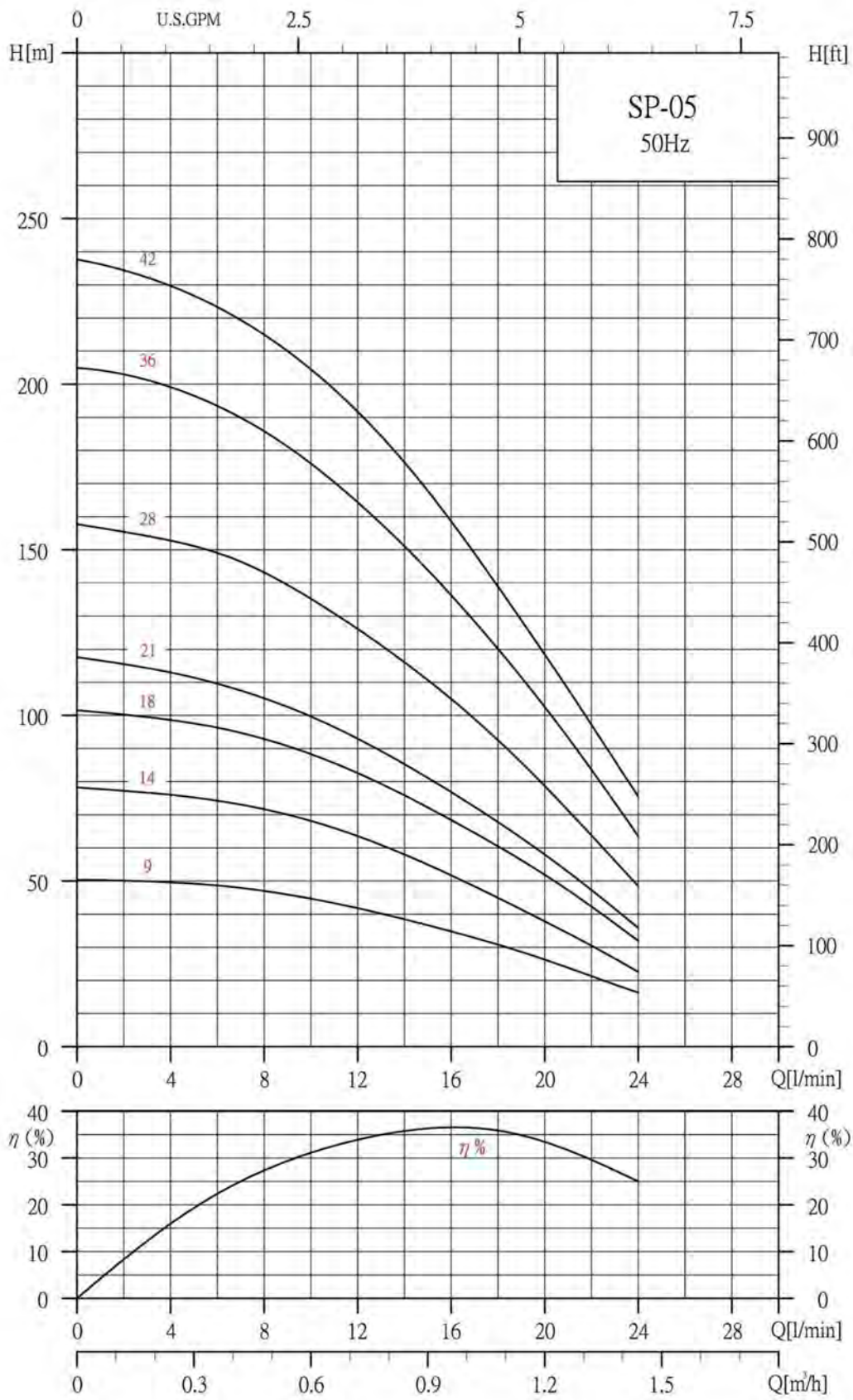

ORLANDO srl

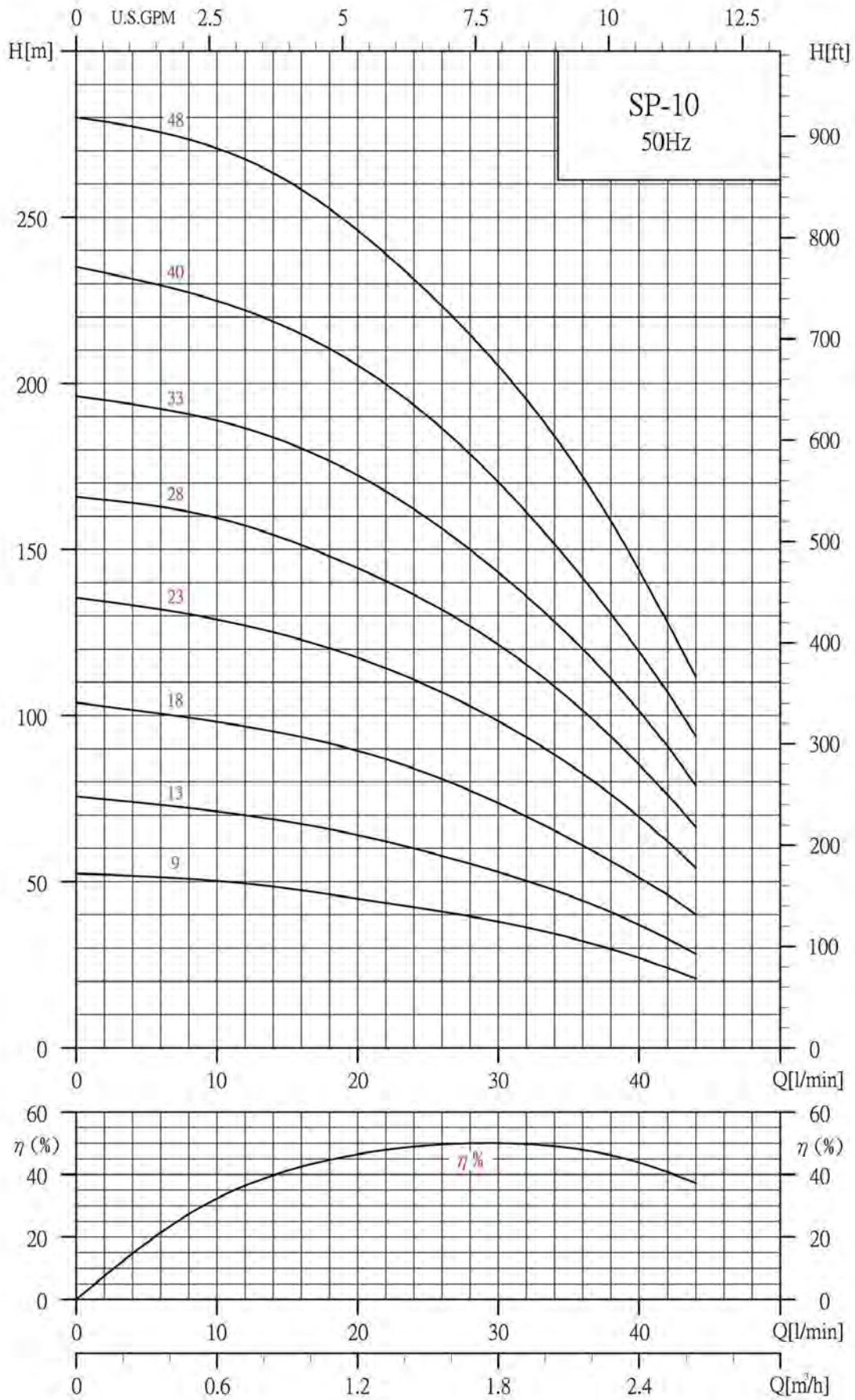

ORLANDO orl

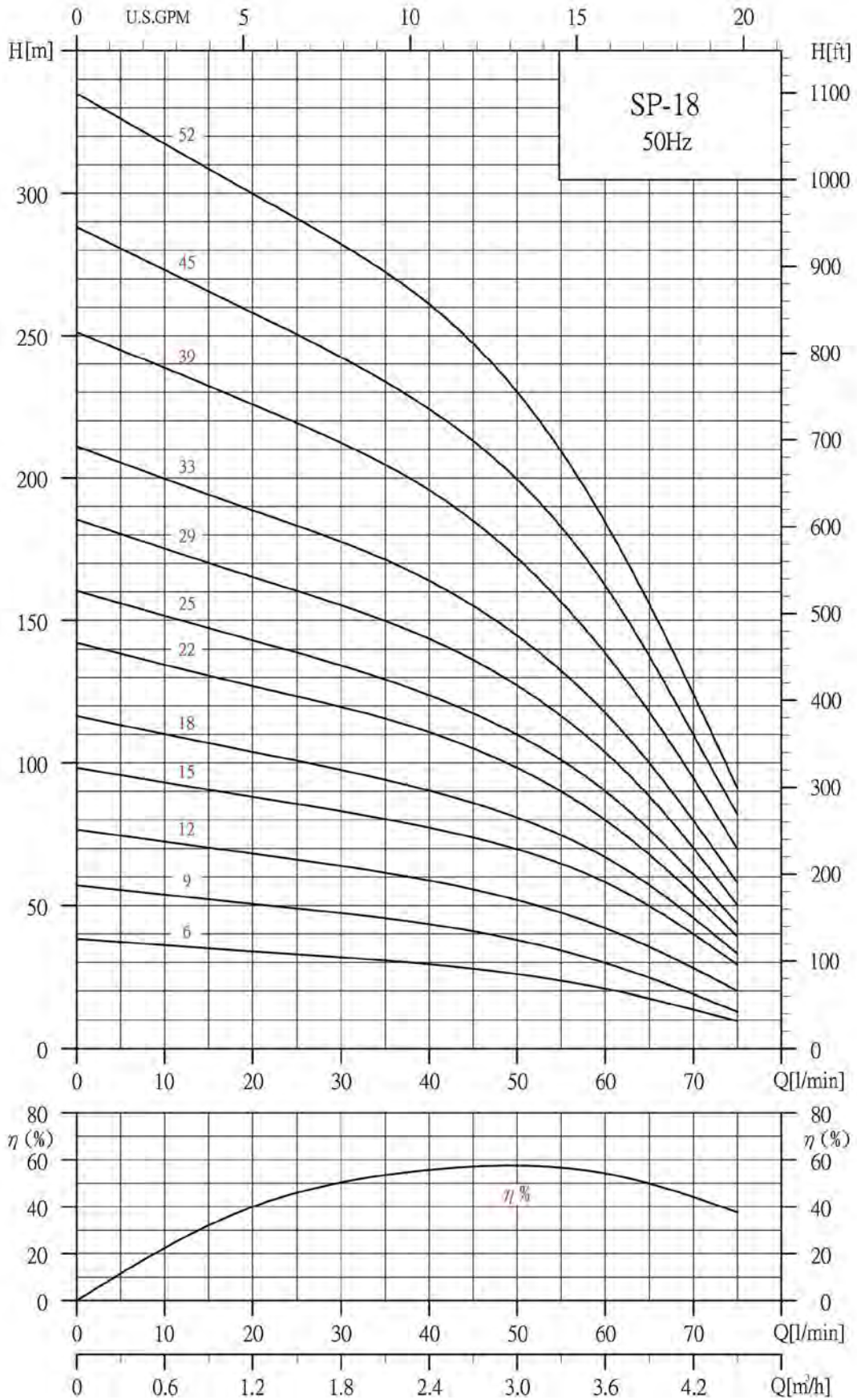

ORLANDO srl

Motor Specification			Pump Specification		
Rating:5.5HP	Phase:3	Voltage:380V	Rating Head:238.9m	Outlet ID: 1.5 in	Liquid:water
Model:	Pole:2P	Current:10.4A	Rating Flow:54.74L/min	Stage: 60	Liquid Poise: 1
Maker:Franklin	Freq.:50Hz	Eff.:77%	Rating Eff.:58.00%	Type:SP18-60	Temper.: 15 C
Serial No:	Insulation:B	S.F.:1		Serial No.:5.5-60	

No.	Q(L/min)	H(m)	Volt	AMP	kw	HP	Eff(%)
1.00	0.00	384.32	385.7	6.766	2.20	1.32	0.00
2.00	0.00	384.68	385.8	6.766	2.20	1.32	0.00
3.00	0.00	384.68	385.8	6.766	2.20	1.32	0.00
4.00	0.00	384.80	385.9	6.766	2.20	1.32	0.00
5.00	0.08	384.88	385.9	6.766	2.20	1.32	0.51
6.00	1.30	382.40	385.9	6.8	2.30	1.45	7.52
7.00	7.74	370.36	385.9	7.100	2.70	1.99	31.48
8.00	16.24	349.20	385.8	7.566	3.20	2.80	44.33
9.00	26.70	328.84	385.7	8.1	3.80	3.85	49.88
10.00	38.00	303.84	385.7	8.700	4.40	4.50	56.15
11.00	46.60	270.48	385.7	9.1	4.70	4.83	57.14
12.00	54.74	238.92	385.6	9.300	4.80	4.94	58.00
13.00	61.18	202.12	385.6	9.200	4.80	4.94	54.84
14.00	67.50	162.84	385.7	9.1	4.70	4.83	49.83
15.00	70.72	133.76	385.8	9	4.70	4.83	42.88
16.00	74.20	107.16	385.9	8.966	4.60	4.72	36.86
17.00	76.68	86.08	385.8	8.833	4.50	4.61	31.33
18.00	78.70	71.24	386.0	8.766	4.40	4.50	27.27
19.00	79.18	56.36	385.9	8.700	4.40	4.50	21.70
20.00	79.66	47.04	385.9	8.666	4.30	4.39	18.68
21.00	80.20	39.64	386	8.666	4.30	4.39	15.85
22.00	80.72	33.36	386.0	8.633	4.30	4.39	13.42
23.00	81.28	28.40	386.0	8.633	4.30	4.39	11.51
24.00	81.48	24.40	386.0	8.666	4.30	4.39	9.91
25.00	82.28	18.00	386.0	8.700	4.40	4.50	7.20
26.00	82.86	14.00	386.1	8.700	4.30	4.39	5.78
27.00	83.16	10.68	386.0	8.666	4.30	4.39	4.43
28.00	83.24	8.48	386.1	8.633	4.30	4.39	3.52
29.00	83.68	6.96	386.1	8.6	4.30	4.39	2.90
30.00	83.78	5.80	386.1	8.6	4.30	4.39	2.42
31.00	83.62	4.92	386.1	8.6	4.30	4.39	2.05
32.00	83.70	2.60	386.2	8.6	4.30	4.39	1.08

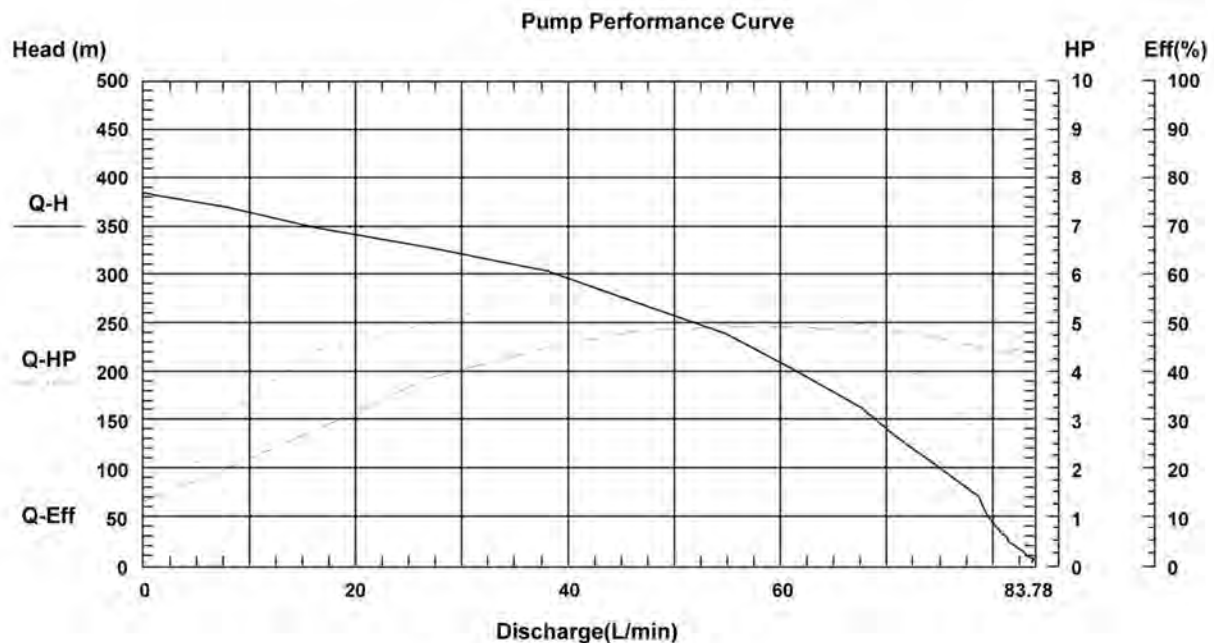

ORLANDO srl

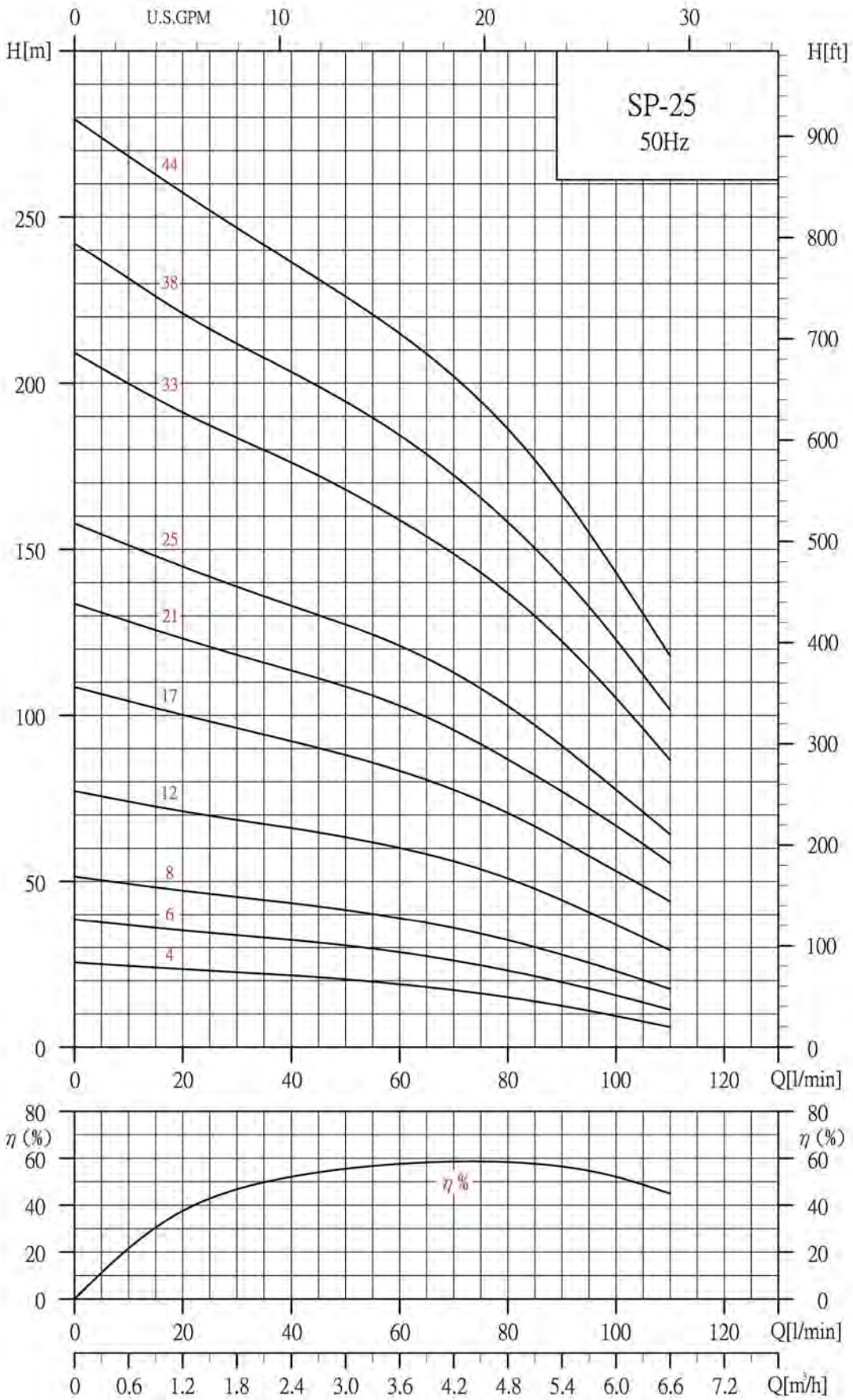

ORLANDO srl

Motor Specification			Pump Specification		
Rating:7.5HP	Phase:3	Voltage:380V	Rating Head:217.8m	Outlet ID: 1.5 in	Liquid:water
Model:	Pole:2P	Current:13A	Rating Flow:81.88L/min	Stage: 52	Liquid Poise: 1
Maker:Franklin	Freq.:50Hz	Eff.:76%	Rating Eff.:63.75%	Type:SP25-52	Temper.: 15 C
Serial No.:	Insulation:B	S.F:1	Serial No.:7.5-52		

No.	Q(L/min)	H(m)	Volt	AMP	kw	HP	Eff(%)
1.00	0.06	332.85	386.1	7.806	2.37	1.09	0.40
2.00	0.00	332.78	386.1	7.816	2.35	1.07	0.00
3.00	0.20	332.53	386.2	7.81	2.35	1.07	1.36
4.00	2.18	330.29	386.2	7.863	2.46	1.17	13.42
5.00	7.92	323.29	386.1	8.056	2.79	1.51	37.10
6.00	17.24	311.32	386.0	8.450	3.34	2.17	54.27
7.00	28.76	298.06	385.9	9.086	4.07	3.22	58.37
8.00	39.36	284.76	385.8	9.686	4.68	4.25	57.72
9.00	53.48	268.76	385.7	10.33	5.27	5.32	59.12
10.00	63.34	254.06	385.7	10.81	5.69	5.77	61.07
11.00	73.50	237.26	385.4	11.10	5.93	6.02	63.40
12.00	81.88	217.87	385.7	11.22	6.03	6.13	63.75
13.00	91.86	192.64	385.7	11.21	6.02	6.12	63.35
14.00	100.12	170.97	385.6	11.12	5.96	6.05	61.91
15.00	106.80	150.95	385.7	11.03	5.88	5.97	59.13
16.00	112.02	135.17	385.7	10.95	5.82	5.91	56.13
17.00	117.38	118.44	385.7	10.85	5.74	5.82	52.28
18.00	121.80	102.65	385.8	10.74	5.64	5.72	47.89
19.00	125.36	90.51	385.7	10.64	5.56	5.63	44.11
20.00	128.02	79.41	385.7	10.56	5.49	5.56	40.06
21.00	129.12	67.62	385.7	10.42	5.36	5.42	35.28
22.00	130.74	59.32	385.8	10.36	5.31	5.37	31.65
23.00	132.72	52.36	385.8	10.31	5.27	5.32	28.58
24.00	134.02	45.74	385.8	10.28	5.24	5.29	25.37
25.00	136.70	34.37	385.8	10.22	5.19	5.23	19.68
26.00	138.38	26.28	385.8	10.17	5.15	5.15	15.47
27.00	140.12	20.89	385.8	10.15	5.13	5.11	12.55
28.00	140.82	16.48	385.8	10.11	5.09	5.03	10.11
29.00	141.36	13.51	385.8	10.09	5.08	5.01	8.35
30.00	142.00	11.30	385.9	10.19	5.16	5.17	6.80
31.00	142.28	9.48	385.9	10.05	5.04	4.93	5.99
32.00	143.50	4.79	386	10.02	5.01	4.87	3.09

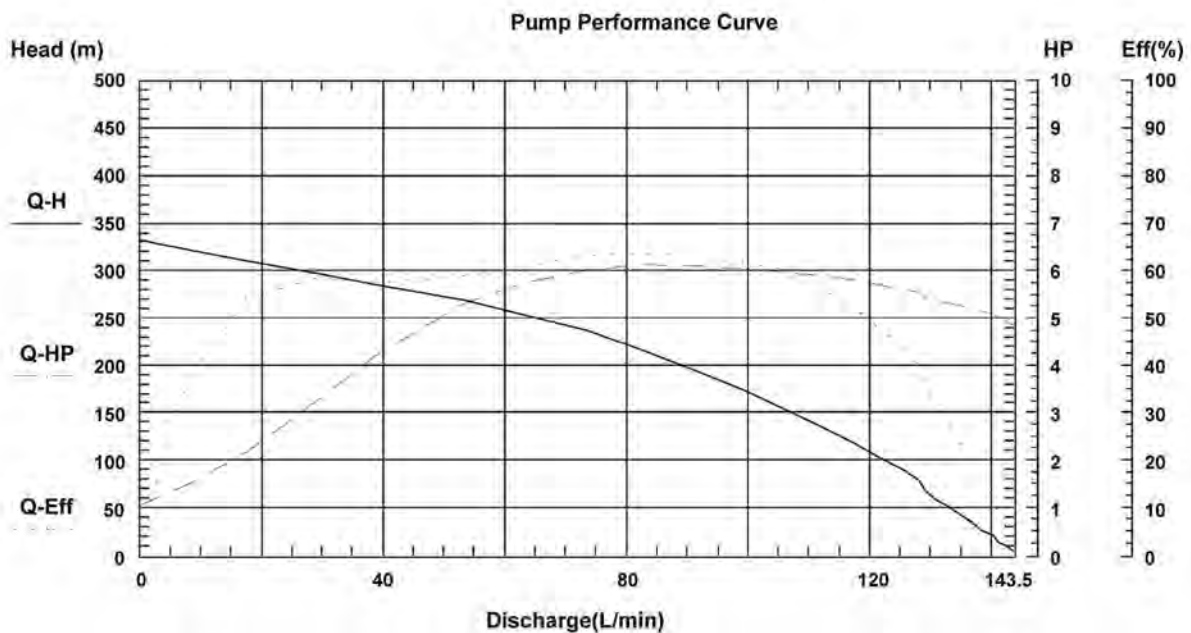

Motor Specification			Pump Specification		
Rating:7.5HP	Phase:3	Voltage:380V	Rating Head:252.2m	Outlet ID: 1.5 in	Liquid:water
Model:	Pole:2P	Current:13A	Rating Flow:78.42L/min	Stage: 60	Liquid Poise: 1
Maker:Franklin	Freq.:50Hz	Eff.:76%	Rating Eff.:64.64%	Type:SP25-60	Temper.: 15 C
Serial No:	Insulation:B	S.F:1	Customer:	Serial No.:7.5-60	

No.	Q(L/min)	H(m)	Voit	AMP	kw	HP	Eff(%)
1.00	0.08	374.22	381.2	7.533	2.50	1.21	0.54
2.00	0.76	375.44	383.1	7.7	2.50	1.21	5.15
3.00	0.08	375.44	383.8	7.7	2.50	1.21	0.54
4.00	0.52	375.44	383.8	7.733	2.50	1.21	3.52
5.00	0.44	375.08	383.8	7.733	2.50	1.21	2.98
6.00	3.82	371.39	383.7	7.9	2.80	1.52	20.41
7.00	11.64	359.15	383.7	8.233	3.30	2.11	43.30
8.00	20.76	344.84	383.5	8.833	4.00	3.11	50.47
9.00	31.00	332.96	383.4	9.533	4.60	4.11	55.02
10.00	42.62	316.31	381.9	10.2	5.20	5.25	56.24
11.00	54.86	301.10	381.8	10.9	5.80	5.89	61.45
12.00	67.04	277.70	382.0	11.56	6.30	6.40	63.68
13.00	78.42	252.27	382.0	11.86	6.60	6.70	64.64
14.00	86.20	225.36	365.5	11.76	6.50	6.60	64.43
15.00	93.90	202.32	381.6	11.8	6.50	6.60	63.01
16.00	101.54	182.03	384.2	11.76	6.50	6.60	61.30
17.00	108.78	160.02	384.6	11.6	6.40	6.50	58.61
18.00	114.66	136.98	384.6	11.5	6.30	6.40	53.73
19.00	118.30	119.88	364.2	11.1	6.00	6.10	50.94
20.00	122.64	106.47	385.4	11.26	6.10	6.20	46.13
21.00	126.08	93.11	385.5	11.13	6.00	6.10	42.16
22.00	127.88	81.00	385.5	11	5.90	5.99	37.86
23.00	129.08	68.36	385.6	10.8	5.70	5.78	33.43
24.00	129.46	58.41	385.7	10.73	5.70	5.78	28.65
25.00	130.52	43.65	385.7	10.7	5.70	5.78	21.58
26.00	133.60	33.80	385.6	10.7	5.60	5.68	17.42
27.00	136.76	25.29	385.7	10.63	5.60	5.68	13.35
28.00	136.80	19.53	385.7	10.63	5.60	5.68	10.31
29.00	136.62	15.84	385.7	10.6	5.60	5.68	8.35
30.00	135.70	12.74	385.7	10.6	5.50	5.57	6.80
31.00	136.08	10.49	385.7	10.6	5.50	5.57	5.61
32.00	137.46	4.41	385.8	10.6	5.50	5.57	2.39

Pump Performance Curve

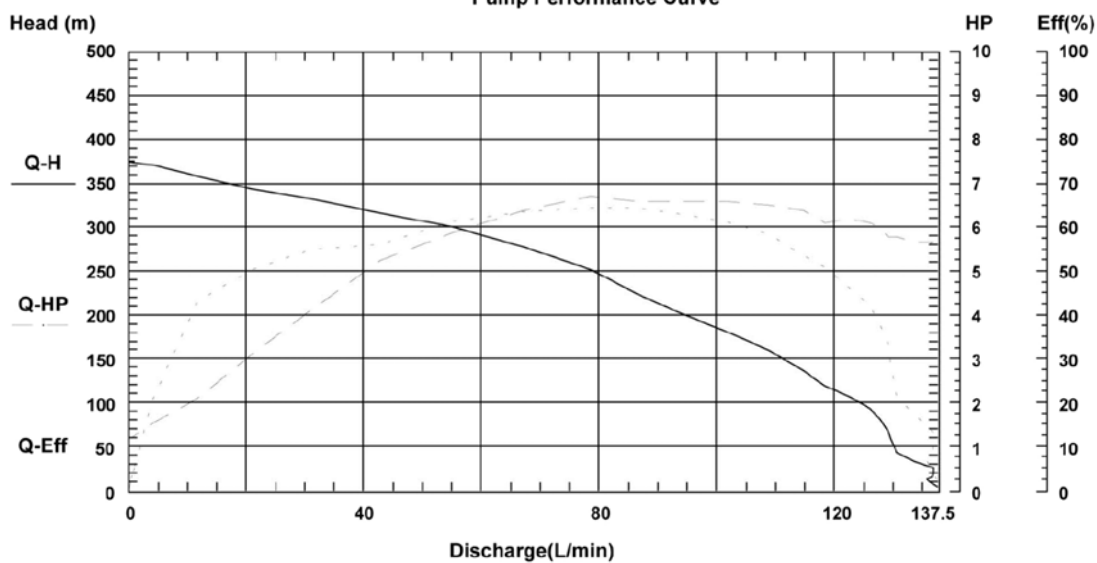

Approved by:

Reviewed by:

Tested by:

ORLANDO srl

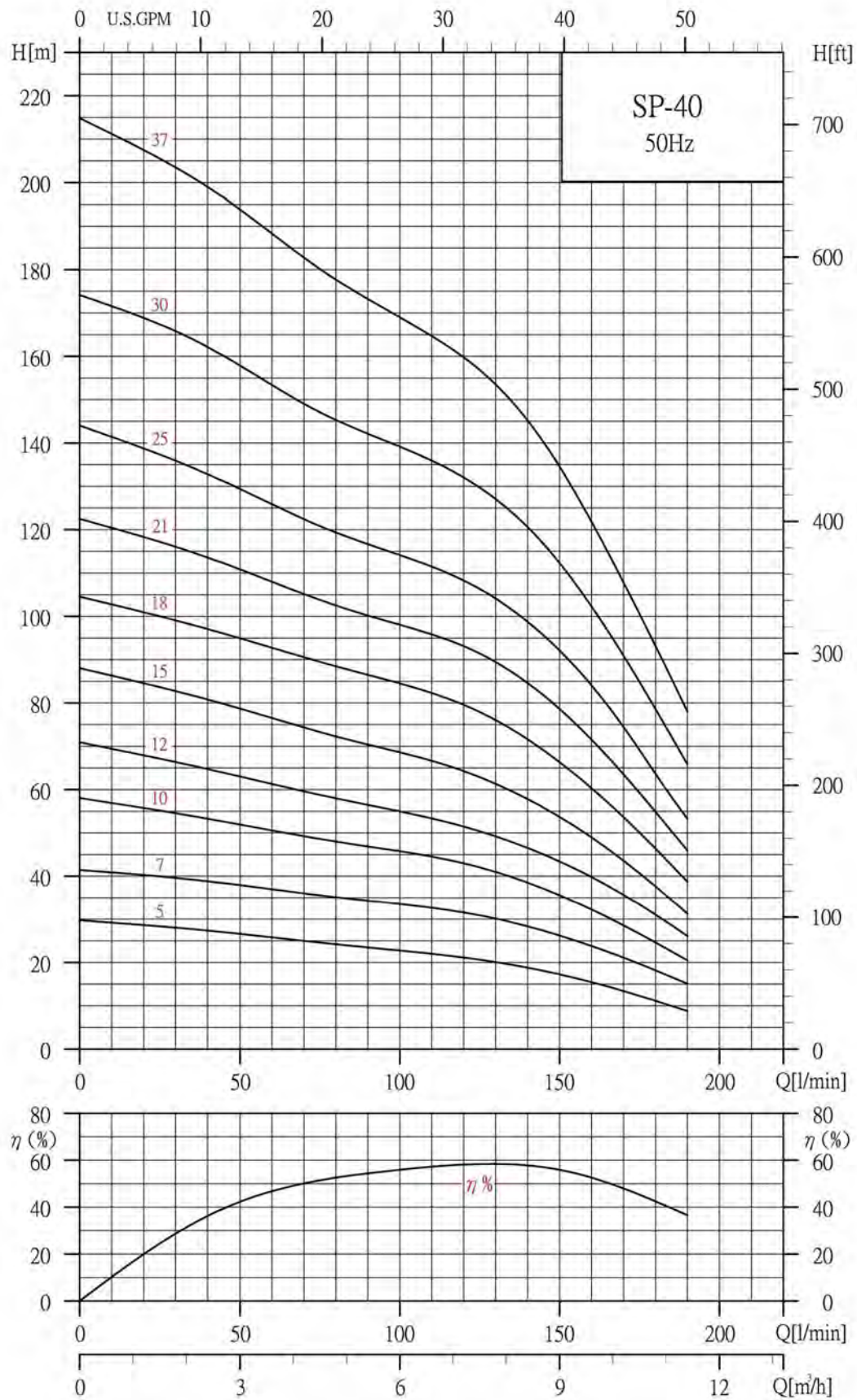

ORLANDO srl

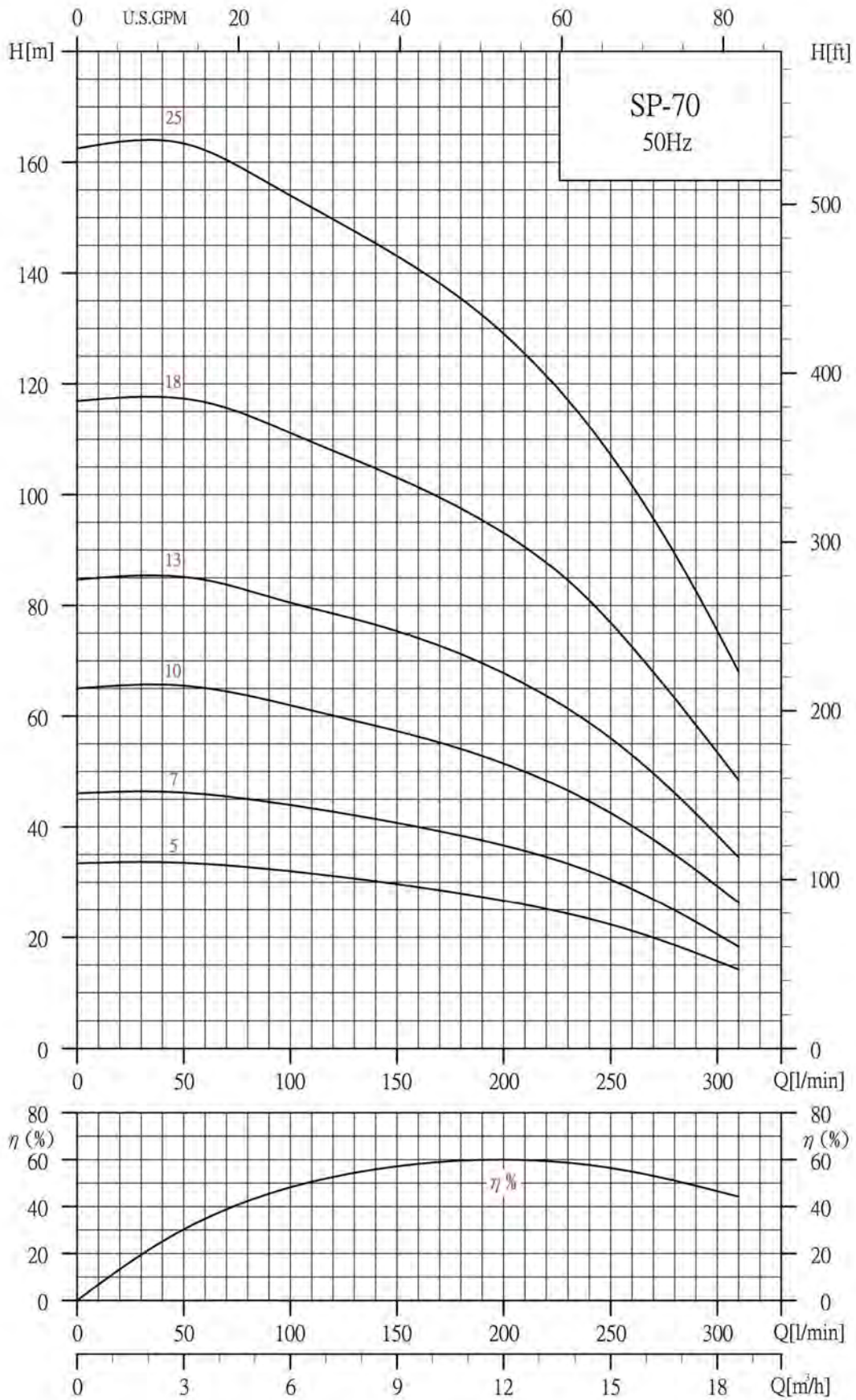

ORLANDO srl

Pump Type	Dimensions(mm)			Net Weight(kg)
	A	B	C	Pump
SP-0509	356	RP/NPT 1 1/4"	98	2,9
SP-0514	461		98	3,7
SP-0518	545		98	4,4
SP-0521	608		98	5,0
SP-0528	755		98	6,2
SP-0536	946		98	9,9
SP-0542	1072		98	11,3

C = Maximum diameter of pump inclusive of cable guard and motor.

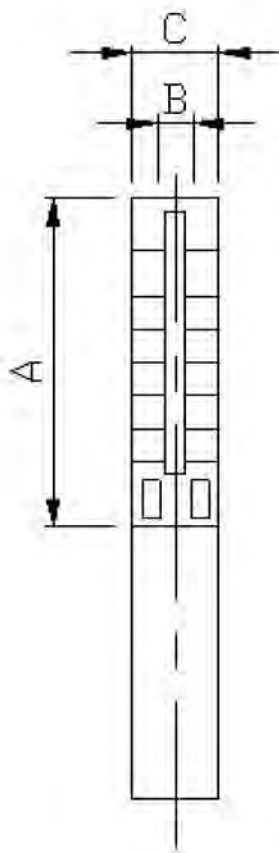

Pump Type	Dimensions(mm)			Net Weight(kg)
	A	B	C	Pump
SP-1009	356	RP/NPT 1 1/4"	98	3,0
SP-1013	440		98	3,8
SP-1018	545		98	4,7
SP-1023	650		98	5,7
SP-1028	755		98	6,6
SP-1033	883		98	9,7
SP-1040	1030		98	11,5
SP-1048	1198		98	13,5

C = Maximum diameter of pump inclusive of cable guard and motor.

Pump Type	Dimensions(mm)			Net Weight(kg)
	A	B	C	Pump
SP-1806	293	RP/NPT 1 1/4"	98	2,4
SP-1809	356		98	3,0
SP-1812	419		98	3,6
SP-1815	482		98	4,2
SP-1818	545		98	4,7
SP-1822	629		98	5,5
SP-1825	692		98	6,1
SP-1829	776		98	6,8
SP-1833	883		98	9,7
SP-1839	1009		98	11,2
SP-1845	1135		98	12,7
SP-1852	1282		98	14,5

C = Maximum diameter of pump inclusive of cable guard and motor.

Pump Type	Dimensions(mm)			Net Weight(kg) Pump
	A	B	C	
SP-2504	251	RP/NPT 1 1/2"	98	2,0
SP-2506	293		98	2,4
SP-2508	335		98	2,8
SP-2512	419		98	3,6
SP-2517	524		98	4,5
SP-2521	608		98	5,3
SP-2525	692		98	6,0
SP-2533	868		98	9,6
SP-2538	973		98	10,9
SP-2544	1099		98	12,4

C = Maximum diameter of pump inclusive of cable guard and moter.

Dimensions and Weights

50HZ

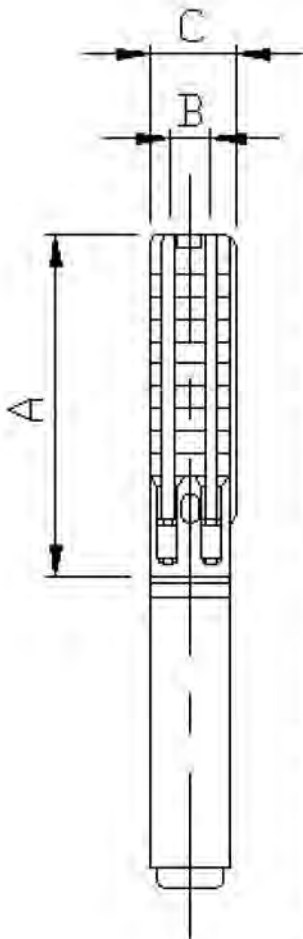

Pump Type	Dimensions(mm)			Net Weight(kg) Pump
	A	B	C	
SP-4005	412	RP/NPT 2"	98	4,3
SP-4007	496		98	5,3
SP-4010	622		98	6,8
SP-4012	706		98	7,8
SP-4015	832		98	9,3
SP-4018	958		98	10,8
SP-4021	1084		98	12,3
SP-4025	1252		98	14,3
SP-4030	1462		98	16,8
SP-4037	1753		98	20,3

C = Maximum diameter of pump inclusive of cable guard and moter.

Pump Type	Dimensions(mm)			Net Weight(kg) Pump
	A	B	C	
SP-7005	505	RP/NPT 2"	98	5,0
SP-7007	635		98	6,3
SP-7010	830		98	8,2
SP-7013	1025		98	10,2
SP-7018	1350		98	13,4
SP-7025	1805		98	17,8

C = Maximum diameter of pump inclusive of cable guard and moter.

ORLANDO srl



PV ST

4" SUBMERSIBLE PUMPS WITH NORYL IMPELLER

4" ST series of pumps are manufactured using high quality materials and are designed to deliver years of dependable service. Pumps are equipped with floating impellers to reduce the high starting torque and increase the sand resistance.

APPLICATIONS: Water plants and systems for residential and industrial use - Truf watering - Pressurizing systems - Irrigation - Stock watering - Drainage and dewatering

PUMPED LIQUIDS: Clean, thin, free from solid or abrasive substances, compatible with pump components and materials.

OPERATING CONDITIONS: Max liquid temperature: 30°C - Sand content: Max 180 g/m³

FEATURES: Heavy-duty stainless steel discharge head with large durable lifting eye and built-in check valve for long life and ease of installation - Stainless steel shaft, shell, intake screen and cable shield for corrosion resistance and longer life - Noryl impeller stage assemblies for incredible strength and durability - External stainless steel sleeve improves stiffness and assures permanent alignment of all the components - High quality shaft bearings providing low friction and high wear resistance - Shaft for pumps with more than 19 stages are supplied with two shaft bearings.

ORLANDO srl

PUMP TYPE 50HZ	STAGES	MOTOR		Q=DELIVERY																										PUMP	
		KW	HP	l/min	80	90	100	120	140	160	180	200	220	240	260	280	300	320	340	360	380	400	450	500	Length (mm)	Weight (kg)					
				m ³ /h	4,8	5,4	6,0	7,2	8,4	9,6	10,8	12	13	14,4	16	17	18	19	20	22	23	24	27	30							
H=TOTAL HEAD IN METERS																															
ST-6007	7	1,5	2,0	45			37	36	33	31	28	25	22	18	14												534	5,3	V		
ST-6010	10	2,2	3,0	64			54	52	48	44	41	36	32	26	20												690	6,7	V		
ST-6014	14	3,0	4,0	89			76	72	67	62	56	49	43	35	28												989	8,6	V		
ST-6017	17	3,7	5,0	107			90	86	80	74	67	59	51	42	32												1092	10,1	V		
ST-6019	19	4,0	5,5	120			102	97	91	89	76	68	58	48	37												1195	11,0	V		
ST-6026	26	5,5	7,5	163			136	129	120	111	100	87	75	61	48												1559	14,3	V		
ST-8008	8	2,2	3,0	51					41	39	37	35	33	31	29	27	24	22	20	17	14	12					676	6,3	V		
ST-8011	11	3,0	4,0	70					57	54	52	49	47	44	41	38	34	31	28	24	21	18					880	8,1	V		
ST-8013	13	3,7	5,0	81					67	64	61	58	55	52	48	45	41	38	34	30	26	22					1013	9,3	V		
ST-8015	15	4,0	5,5	97					79	76	73	69	66	63	58	54	50	46	41	36	32	27					1149	10,5	V		
ST-8020	20	5,5	7,5	125					102	98	94	89	84	79	74	70	65	60	54	48	43	37					1489	13,5	V		
ST-8026	26	7,5	10	158			140	133	126	121	116	112	106	100	95	92	88	80	73	65	56	46					1810	17,5	V		

V = Available

No = Not available

Performance Curves

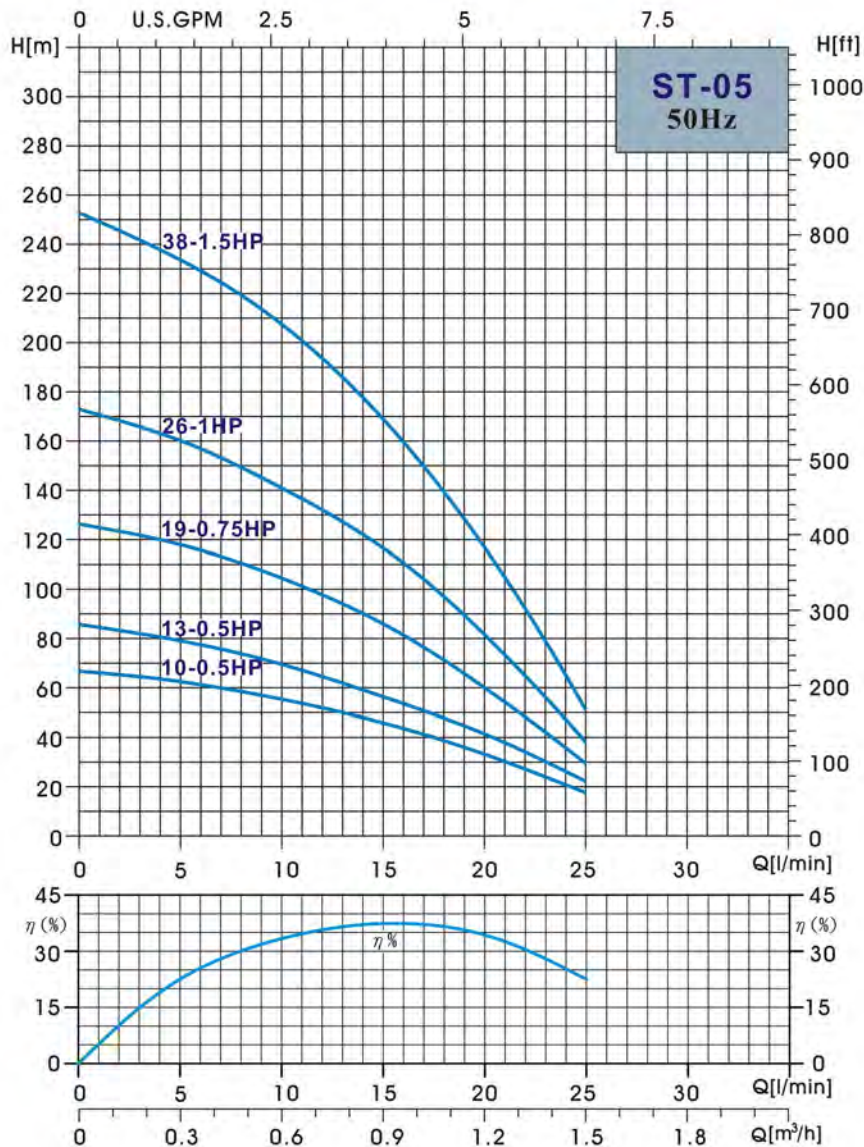

1" 1/4



Selection Chart																			
PUMP TYPE	Stages	Motor		Q = DELIVERY														PUMP	
				l/min 0	5	10	15	20	25	30	35	40	45	50	60	70	80		
		KW	HP	m³/h 0	0.3	0.6	0.9	1.2	1.5	1.8	2.1	2.4	2.7	3.0	3.6	4.2	4.8	Length (mm)	Weight (kg)
H = TOTAL HEAD IN METERS																			
ST-0510	10	0.37	0.5	67	63	55	46	33	18								324	3.3	
ST-0513	13	0.37	0.5	86	78	70	56	42	23								377	3.7	
ST-0519	19	0.55	0.75	126	118	105	86	60	30								481	4.7	
ST-0526	26	0.75	1.0	173	160	141	117	81	39								642	5.8	
ST-0538	38	1.1	1.5	253	234	208	169	117	52								864	8.2	

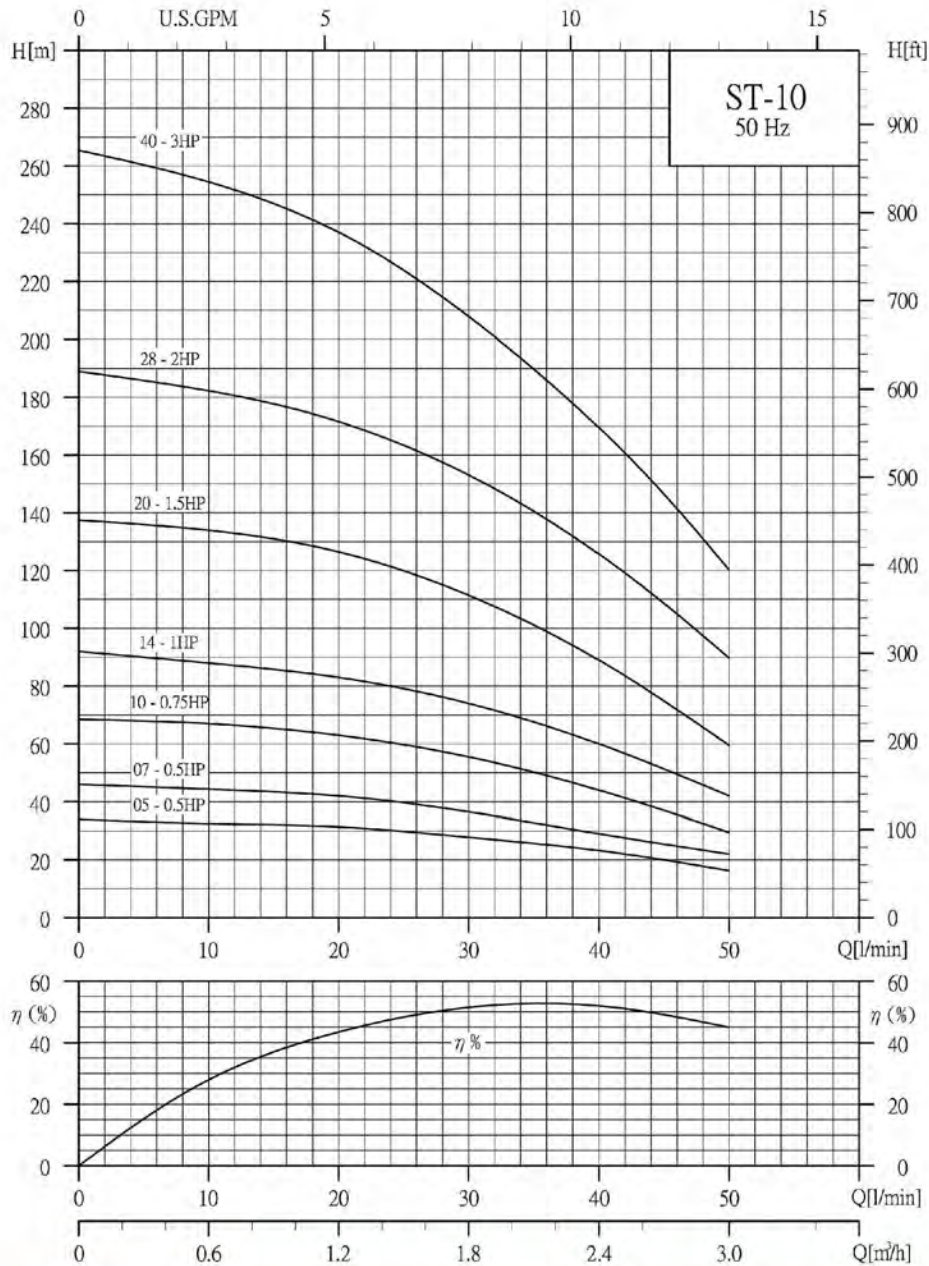

1" 1/4



Selection Chart																			
PUMP TYPE	Stages	Motor		Q=DELIVERY														PUMP	
		KW	HP	l/min	5	10	15	20	25	30	35	40	45	50	60	70	80	Length (mm)	Weight (kg)
				m ³ /h	0.3	0.6	0.9	1.2	1.5	1.8	2.1	2.4	2.7	3.0	3.6	4.2	4.8		
H=TOTAL HEAD IN METERS																			
ST-1005	5	0.37	0.5	34			32	31	29	27	25	23	19	16				236	2.5
ST-1007	7	0.37	0.5	46			43	42	39	36	33	29	26	22				271	2.8
ST-1010	10	0.55	0.75	69			65	63	60	55	50	44	37	29				324	3.3
ST-1014	14	0.75	1.0	92			86	83	79	74	67	60	52	42				394	3.9
ST-1020	20	1.1	1.5	139			131	127	120	111	101	90	75	60				499	4.9
ST-1028	28	1.5	2	189			178	172	164	153	140	126	108	90				680	6,9
ST-1040	40	2,2	3	265			247	237	224	208	189	170	147	120				885	9,3

ORLANDO srl

1" 1/4

Performance Curves

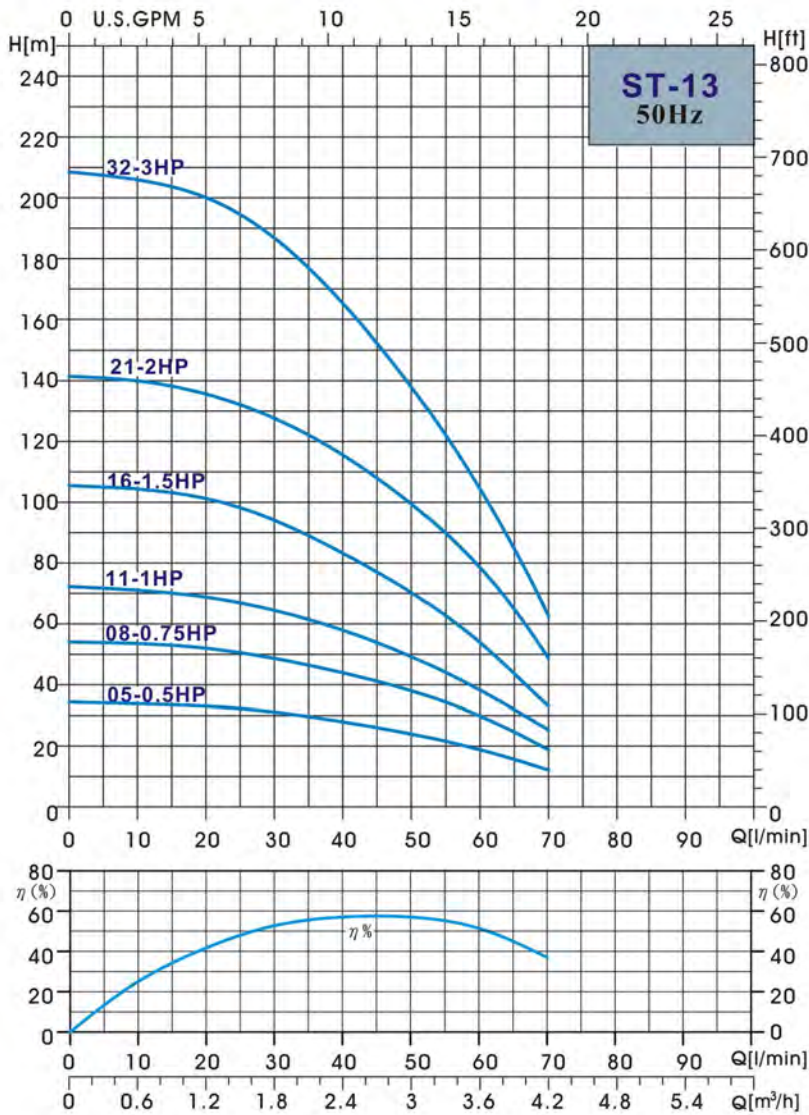

Selection Chart		Q=DELIVERY																		PUMP	
PUMP TYPE	Stages	Motor		Q=DELIVERY																Length (mm)	Weight (kg)
		KW	HP	l/min 0	5	10	15	20	25	30	35	40	45	50	60	70	80				
				H=TOTAL HEAD IN METERS																	
				m³/h 0	0.3	0.6	0.9	1.2	1.5	1.8	2.1	2.4	2.7	3.0	3.6	4.2	4.8				
ST-1305	5	0.37	0.5	34				32	31	30	29	28	26	24	19	13		236	2.5		
ST-1308	8	0.55	0.75	54				51	50	49	46	43	41	38	30	19		289	2.9		
ST-1311	11	0.75	1.0	72				68	66	64	61	58	54	49	38	26		342	3.4		
ST-1316	16	1.1	1.5	106				101	98	95	89	83	77	70	54	33		430	4.2		
ST-1321	21	1.5	2.0	142				135	132	127	122	115	108	100	79	49		519	5.0		
ST-1332	32	2.2	3.0	208				200	194	187	177	165	152	138	104	62		749	7.1		

ORLANDO srl

Performance Curves

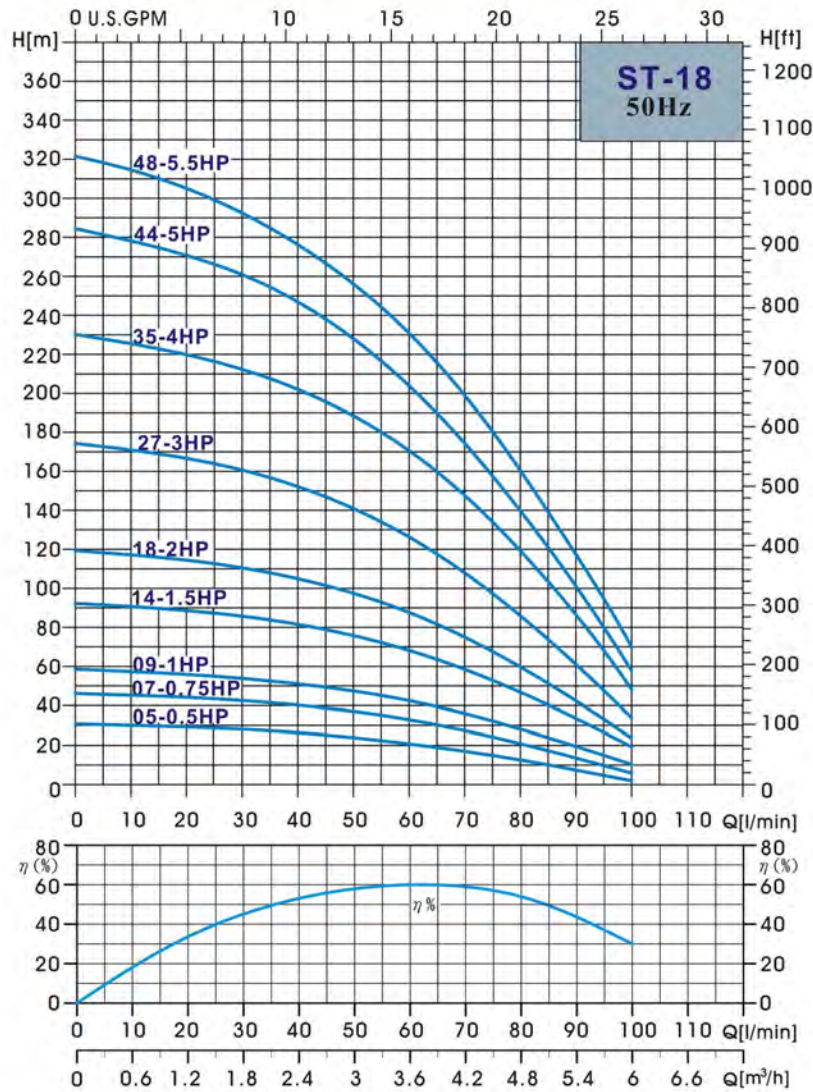

1" 1/4



Selection Chart																				
PUMP TYPE	Stages	Motor		Q = DELIVERY														PUMP		
		KW	HP	l/min	15	20	25	30	35	40	45	50	60	70	80	90	100	120	Length (mm)	Weight (kg)
				m³/h	0.9	1.2	1.5	1.8	2.1	2.4	2.7	3.0	3.6	4.2	4.8	5.4	6.0	7.2		
H = TOTAL HEAD IN METERS																				
ST-1805	5	0.37	0.5	33			29	28	27	26	25	24	21	18	13	8	3		257	2.7
ST-1807	7	0.55	0.75	46			43	42	41	40	39	37	33	28	21	13	7		301	3.0
ST-1809	9	0.75	1.0	59			55	54	52	51	49	47	43	37	28	20	10		344	3.3
ST-1814	14	1.1	1.5	93			87	86	83	81	79	76	68	58	47	33	20		452	4.1
ST-1818	18	1.5	2.0	120			113	111	108	105	102	98	88	75	60	42	25		538	4.7
ST-1827	27	2.2	3.0	175			164	161	157	152	147	141	127	109	87	61	35		767	6.2
ST-1835	35	3.0	4.0	231			217	212	208	202	196	189	170	149	120	87	50		934	7.9
ST-1844	44	3.7	5.0	285			266	260	254	248	238	229	203	172	139	100	59		1128	9.3
ST-1848	48	4.0	5.5	322			299	292	285	276	267	256	231	199	160	118	70		1253	9.9

ORLANDO srl

1" 1/2

Performance Curves

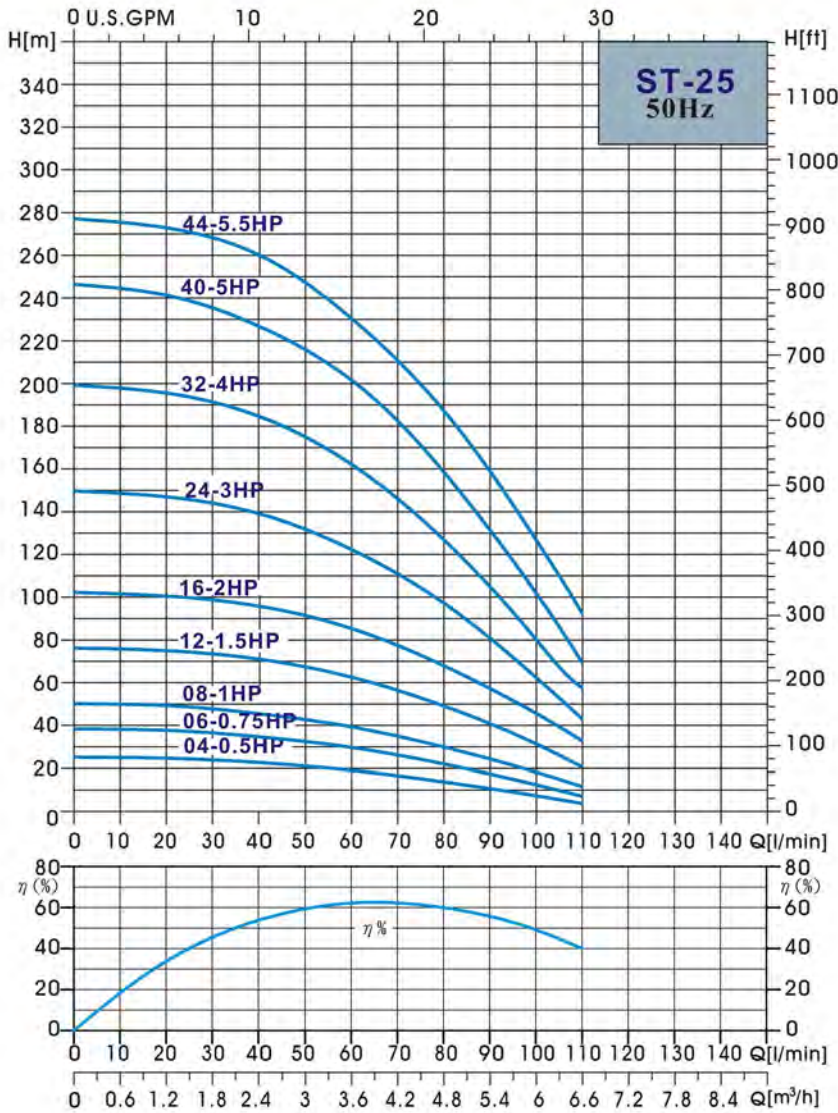

PUMP TYPE		Stages	Motor		Q = DELIVERY															PUMP			
			KW	HP	l/min 0	30	35	40	45	50	60	70	80	90	100	120	140	160	180	200	220	Length (mm)	Weight (kg)
				m³/h 0	1.8	2.1	2.4	2.7	3.0	3.6	4.2	4.8	5.4	6.0	7.2	8.4	9.6	10.8	12	13			
				H = TOTAL HEAD IN METERS																			
ST-2504	4	0.37	0.5	26	23	22	22	21	19	17	14	11	7									247	2.4
ST-2506	6	0.55	0.75	38	36	35	33	32	30	26	22	18	12									296	2.9
ST-2508	8	0.75	1.0	51	47	46	44	43	39	35	30	24	18									345	3.3
ST-2512	12	1.1	1.5	77	72	71	69	68	63	57	49	41	31									433	4.1
ST-2516	16	1.5	2.0	102	98	96	94	92	86	77	68	57	46									542	5.0
ST-2524	24	2.2	3.0	151	142	139	136	132	122	111	97	80	62									777	6.6
ST-2532	32	3.0	4.0	203	188	185	180	175	162	146	127	105	80									965	8.7
ST-2540	40	3.7	5.0	253	232	227	222	216	202	182	159	131	102									1160	10.4
ST-2544	44	4.0	5.5	278	265	260	254	247	230	210	187	159	127									1296	11.2

Performance Curves

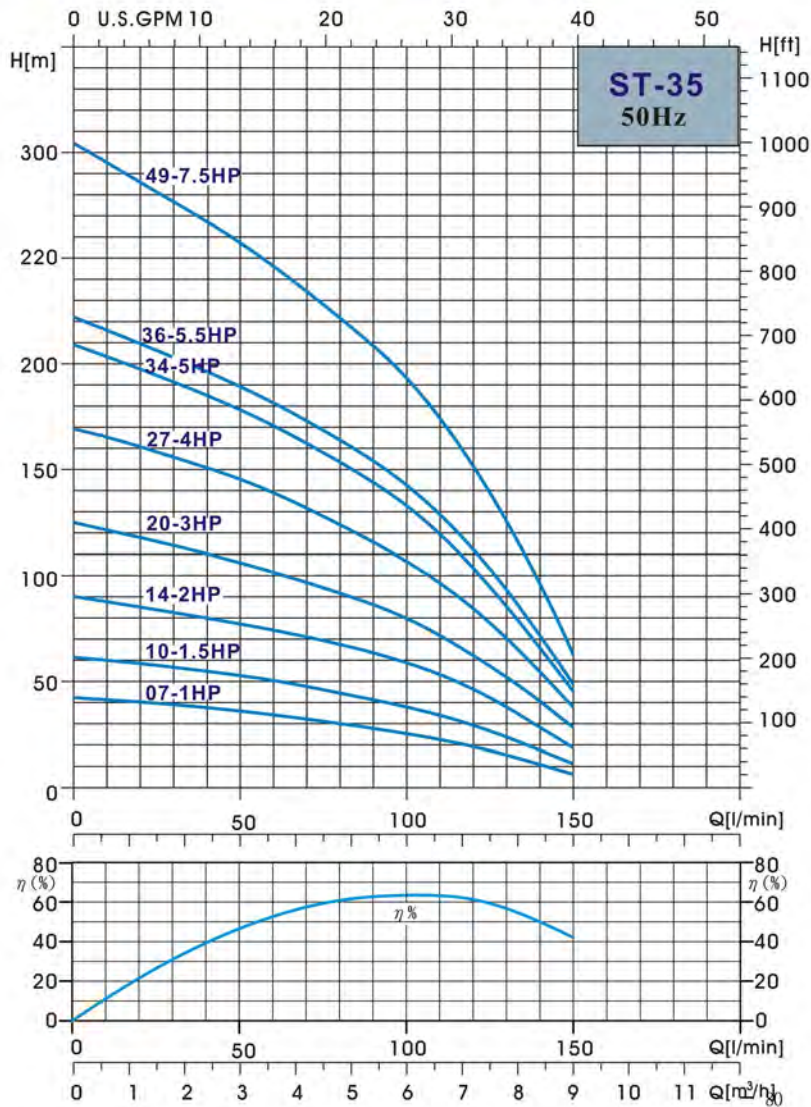

Selection Chart																							
PUMP TYPE	Stages	Motor		Q=DELIVERY																		PUMP	
		KW	HP	l/min	30	35	40	45	50	60	70	80	90	100	120	140	160	180	200	220	Length (mm)	Weight (kg)	
				m³/h	0	1.8	2.1	2.4	2.7	3.0	3.6	4.2	4.8	5.4	6.0	7.2	8.4	9.6	10.8	12			13
H=TOTAL HEAD IN METERS																							
ST-3507	7	0.75	1.0	42					36	34	32	30	28	25	19	11					390	3.7	
ST-3510	10	1.1	1.5	62					53	51	48	45	41	38	29	18					483	4.6	
ST-3514	14	1.5	2.0	90					77	74	71	68	63	59	46	28					607	5.7	
ST-3520	20	2.2	3.0	125					107	102	97	92	86	80	62	40					831	7.5	
ST-3527	27	3.0	4.0	169					145	139	131	123	115	107	84	55					1048	9.6	
ST-3534	34	3.7	5.0	208					178	170	162	153	143	132	103	66					1257	11.6	
ST-3536	36	4.0	5.5	221					190	181	173	164	154	143	112	72					1318	12.2	
ST-3549	49	5.5	7.5	302					257	246	234	222	209	193	151	96					1802	15.9	

Performance Curves

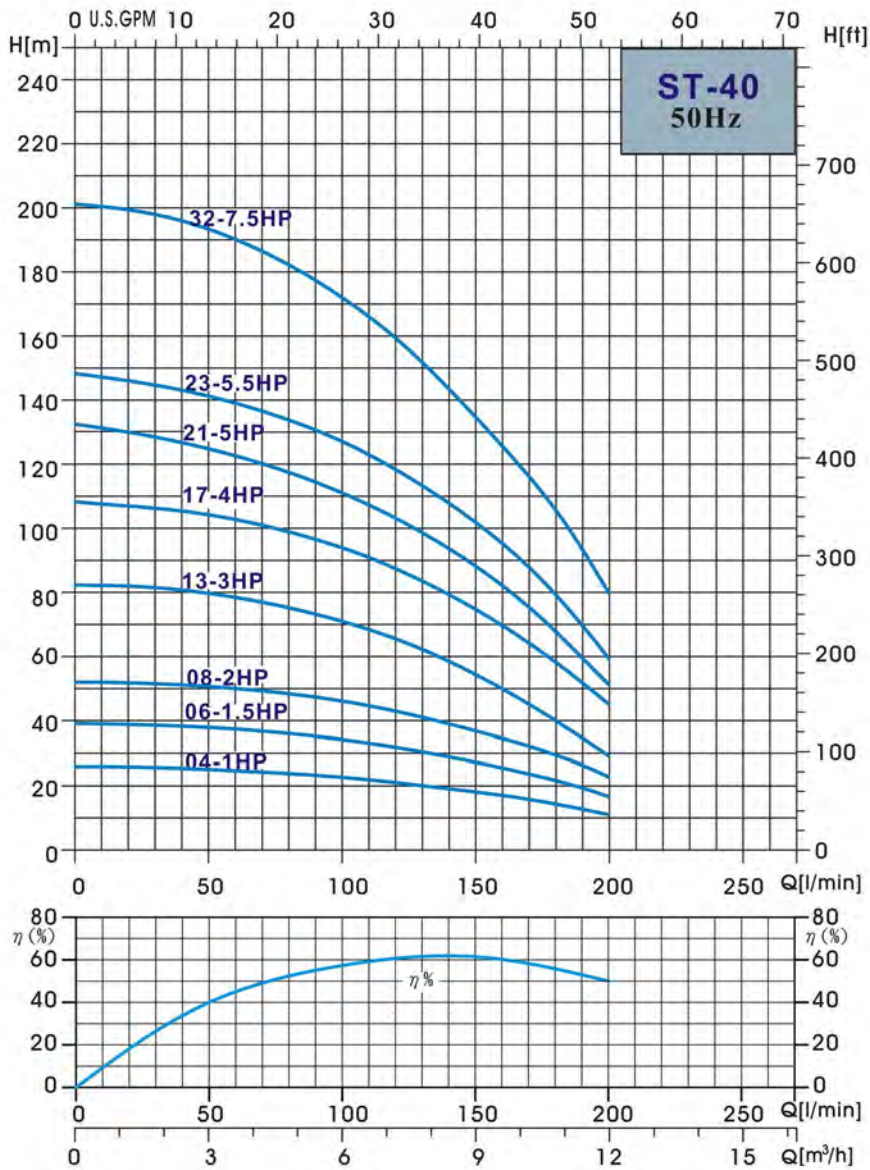

PUMP TYPE		Stages	Motor		Q=DELIVERY														PUMP			
			KW	HP	l/min 0	30	35	40	45	50	60	70	80	90	100	120	140	160	180	200	220	Length (mm)
				m³/h 0	1.8	2.1	2.4	2.7	3.0	3.6	4.2	4.8	5.4	6.0	7.2	8.4	9.6	10.8	12	13		
				H=TOTAL HEAD IN METERS																		
ST-4004	4	0.75	1.0	26								24	23	22	21	19	17	15	12		294	2.8
ST-4006	6	1.1	1.5	39								36	35	34	32	29	26	22	17		356	3.4
ST-4008	8	1.5	2.0	52								48	47	46	43	39	35	29	24		418	4.0
ST-4013	13	2.2	3.0	82								75	73	71	66	59	50	40	30		573	5.5
ST-4017	17	3.0	4.0	108								98	96	94	87	79	70	58	46		697	6.6
ST-4021	21	3.7	5.0	132								117	114	111	103	93	82	68	52		859	7.8
ST-4023	23	4.0	5.5	148								134	131	127	118	108	95	79	60		921	8.4
ST-4032	32	5.5	7.5	202								182	178	172	160	143	125	105	80		1238	11.0

Performance Curves

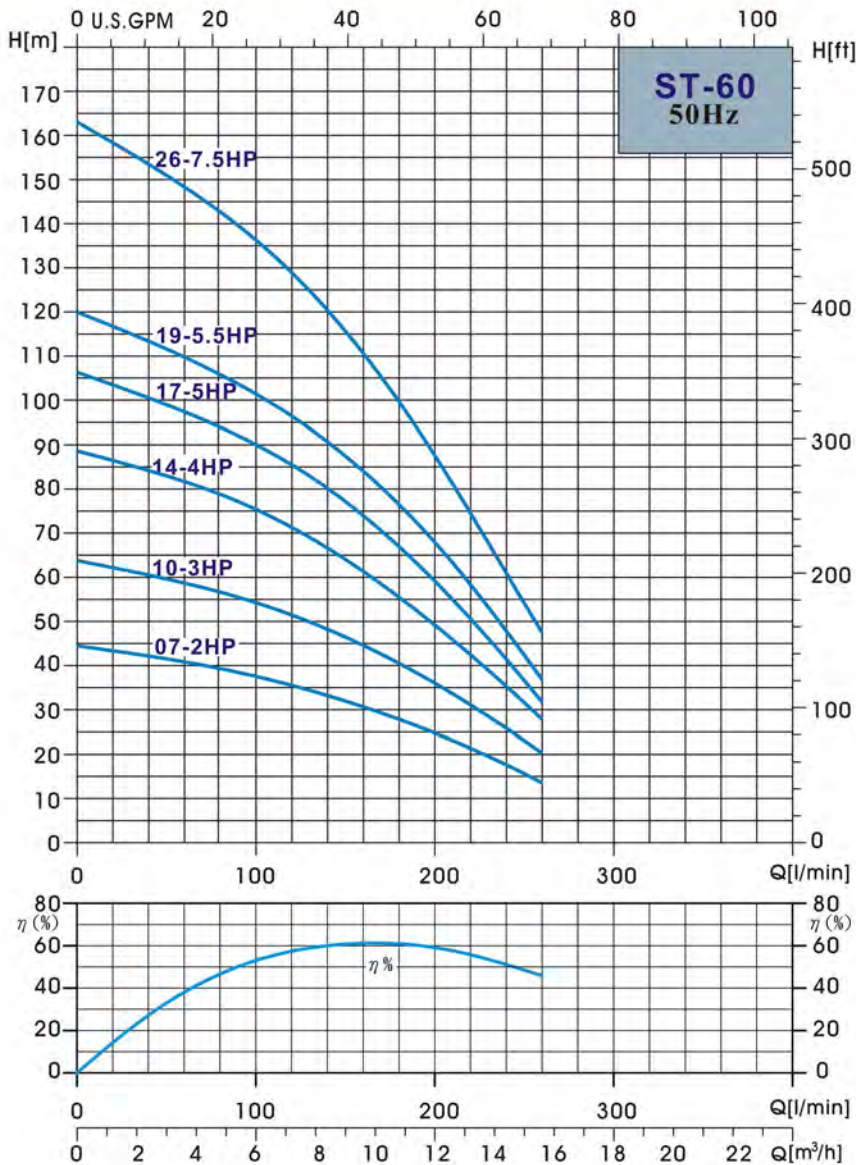

Selection Chart																						
PUMP TYPE	Stages	Motor		Q=DELIVERY																	PUMP	
				l/min	80	90	100	120	140	160	180	200	220	240	260	280	300	320	340	360	Length (mm)	Weight (kg)
		KW	HP	m³/h	4.8	5.4	6.0	7.2	8.4	9.6	10.8	12	13	14.4	16	17	18	19	20	22		
H=TOTAL HEAD IN METERS																						
ST-6007	7	1.5	2.0	45			37	36	33	31	28	25	22	18	14					534	5.3	
ST-6010	10	2.2	3.0	64			54	52	48	44	41	36	32	26	20					690	6.7	
ST-6014	14	3.0	4.0	89			76	72	67	62	56	49	43	35	28					989	8.6	
ST-6017	17	3.7	5.0	107			90	86	80	74	67	59	51	42	32					1092	10.1	
ST-6019	19	4.0	5.5	120			102	97	91	89	76	68	58	48	37					1195	11.0	
ST-6026	26	5.5	7.5	163			136	129	120	111	100	87	75	61	48					1559	14.3	

ORLANDO srl

2"

Performance Curves

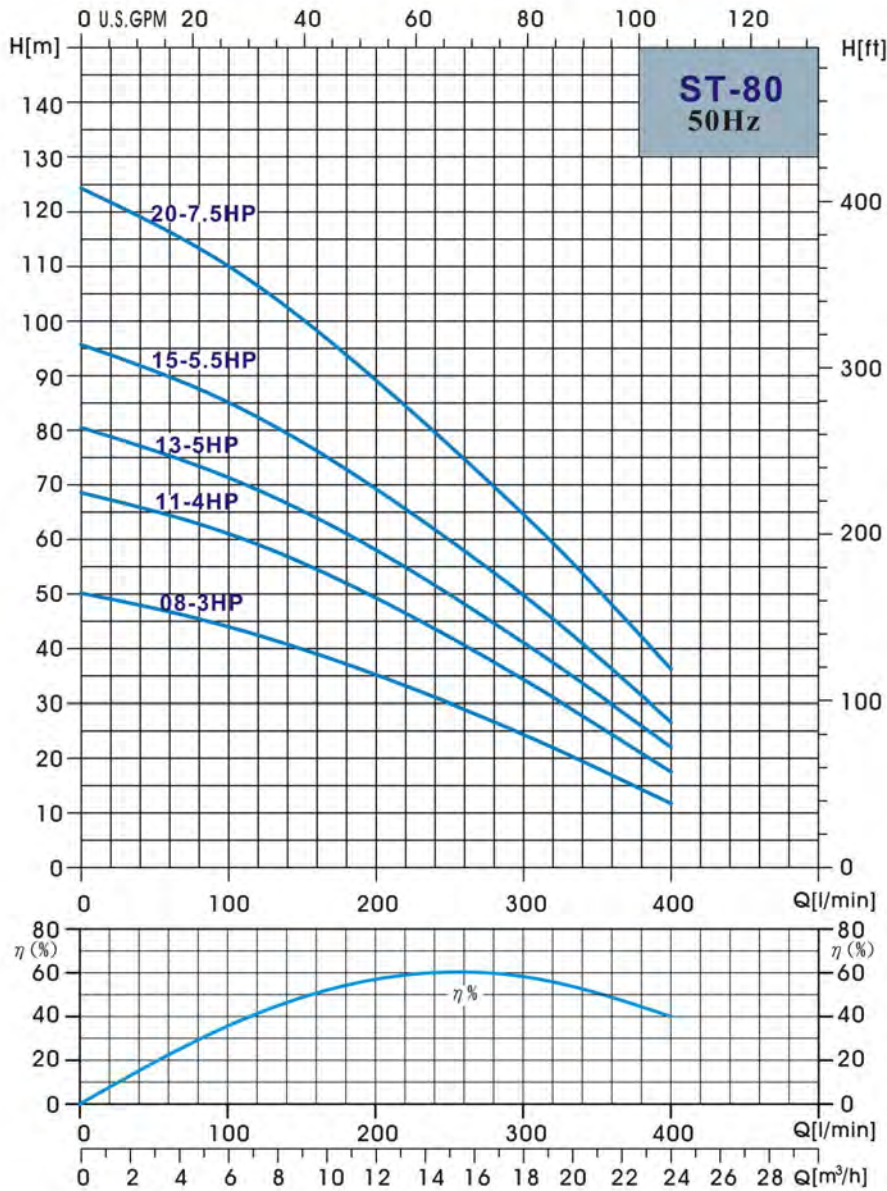

Selection Chart																						
PUMP TYPE	Stages	Motor		Q = DELIVERY																	PUMP	
				l/min	100	120	140	160	180	200	220	240	260	280	300	320	340	360	380	400		
		KW	HP	m³/h	6.0	7.2	8.4	9.6	10.8	12	13	14.4	16	17	18	19	20	22	23	24	27	Length (mm)
ST-8008	8	2.2	3.0	51			41	39	37	35	33	31	29	27	24	22	20	17	14	12	676	6.3
ST-8011	11	3.0	4.0	70			57	54	52	49	47	44	41	38	34	31	28	24	21	18	880	8.1
ST-8013	13	3.7	5.0	81			67	64	61	58	55	52	48	45	41	38	34	30	26	22	1013	9.3
ST-8015	15	4.0	5.5	97			79	76	73	69	66	63	58	54	50	46	41	36	32	27	1149	10.5
ST-8020	20	5.5	7.5	125			102	98	94	89	84	79	74	70	65	60	54	48	43	37	1489	13.5

ORLANDO srl

ST 80 26

Motor Specification			Pump Specification		
Rating:10HP	Phase:3	Voltage:380V	Rating Head:89.35m	Outlet ID: 3 in	Liquid:water
Model:	Pole:2P	Current:18.8A	Rating Flow:295.7L/min	Stage: 26	Liquid Poise: 1
Maker:Franklin	Freq.:50Hz	Eff.:77%	Rating Eff.:63.91%	Type:ST80-26	Temper.: 15 C
Serial No:	Insulation:B	S.F:1		Serial No.:10-26	

No.	Q(L/min)	H(m)	Volt	AMP	kw	HP	Eff(%)
1.00	0.00	158.38	381.0	15.89	8.31	8.55	0.00
2.00	57.40	145.36	381.1	15.74	8.21	8.44	21.64
3.00	106.40	138.22	381.0	16	8.41	8.66	37.20
4.00	154.00	124.26	381.1	16.06	8.48	8.73	47.99
5.00	199.90	111.68	381.1	16.14	8.52	8.77	55.72
6.00	252.70	97.56	381.1	16.4	8.74	9.01	59.91
7.00	295.70	89.36	381.1	16.43	8.78	9.05	63.91
8.00	332.70	76.94	381.2	16.30	8.70	8.97	62.51
9.00	357.50	66.74	381.2	16.13	8.56	8.82	59.26
10.00	384.40	55.20	381.2	16.02	8.47	8.72	53.28
11.00	407.70	43.40	381.2	15.92	8.39	8.63	44.87
12.00	423.60	40.34	381.3	15.81	8.29	8.53	43.88
13.00	435.90	33.16	381.2	15.69	8.21	8.44	37.49
14.00	445.40	29.66	381.3	15.61	8.14	8.37	34.57
15.00	452.60	29.98	381.3	15.54	8.08	8.30	35.78
16.00	457.20	29.06	381.3	15.47	8.01	8.23	35.35
17.00	447.50	19.64	381.3	15.26	7.84	8.05	23.91
18.00	451.20	19.18	381.3	15.21	7.80	8.01	23.67
19.00	454.50	19.36	381.4	15.18	7.78	7.98	24.13
20.00	457.80	14.78	381.4	15.20	7.79	8.00	18.53
21.00	459.90	11.38	381.5	15.17	7.77	7.97	14.37
22.00	461.70	8.40	381.5	15.19	7.78	7.98	10.64
23.00	463.50	16.34	381.5	15.12	7.74	7.94	20.88
24.00	464.30	7.82	381.4	15.08	7.71	7.91	10.05
25.00	466.60	8.46	381.4	15.09	7.70	7.90	10.94
26.00	469.00	5.00	381.3	15.1	7.70	7.90	6.50
27.00	469.60	3.92	381.5	15.10	7.72	7.92	5.09
28.00	469.60	3.70	381.4	15.07	7.70	7.90	4.82
29.00	470.90	2.54	381.5	15.05	7.68	7.88	3.32
30.00	470.90	2.74	381.6	15.04	7.66	7.86	3.60
31.00	472.40	3.88	381.6	15.01	7.65	7.85	5.11
32.00	472.00	1.72	381.6	15.03	7.65	7.85	2.27

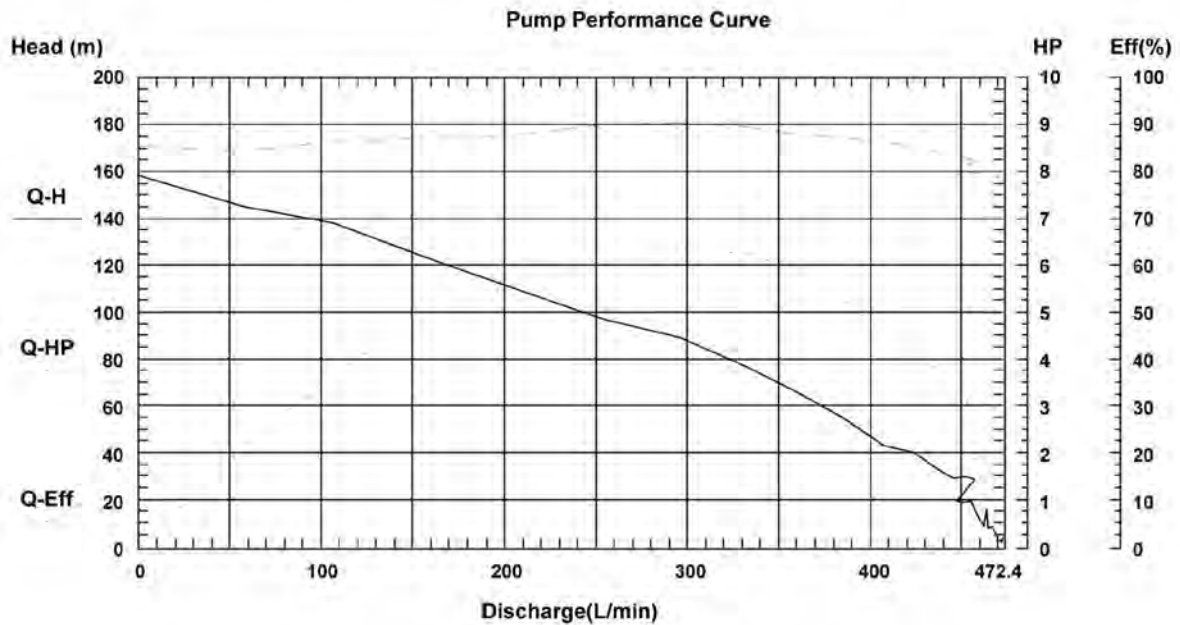

Dimensions and Weights

50HZ

Pump Type	Dimensions(mm)			Net Weight(kg)
	A	B	C	
ST-0510	324	RP/NPT 1 1/4"	98	3,3
ST-0513	377		98	3,7
ST-0519	481		98	4,7
ST-0526	642		98	5,8
ST-0538	864		98	8,2

C = Maximum diameter of pump inclusive of cable guard and motor.

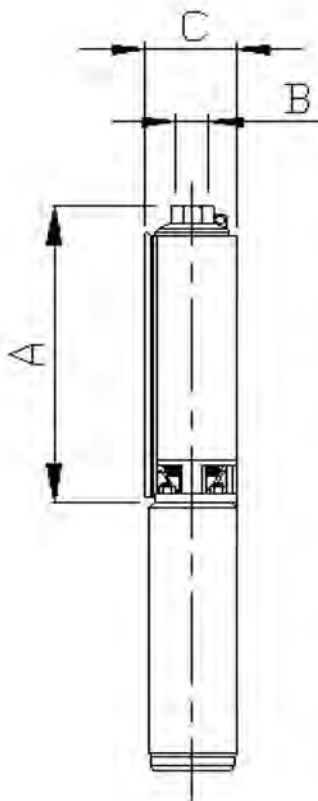

Pump Type	Dimensions(mm)			Net Weight(kg)
	A	B	C	
ST-1005	236	RP/NPT 1 1/4"	98	2,5
ST-1007	271		98	2,8
ST-1010	324		98	3,3
ST-1014	394		98	3,9
ST-1020	499		98	4,9
ST-1028	680		98	6,9
ST-1040	885		98	9,3

C = Maximum diameter of pump inclusive of cable guard and motor.

Pump Type	Dimensions(mm)			Net Weight(kg)
	A	B	C	
ST-1305	236	RP/NPT 1 1/4"	98	2,5
ST-1308	289		98	2,9
ST-1311	342		98	3,4
ST-1316	430		98	4,2
ST-1321	519		98	5,0
ST-1332	749		98	7,1

C = Maximum diameter of pump inclusive of cable guard and motor.

Pump Type	Dimensions(mm)			Net Weight(kg)
	A	B	C	
ST-1805	257	RP/NPT 1 1/4"	98	2,7
ST-1807	301		98	3,0
ST-1809	344		98	3,3
ST-1814	452		98	4,1
ST-1818	538		98	4,7
ST-1827	767		98	6,2
ST-1835	934		98	7,9
ST-1844	1128		98	9,3
ST-1848	1253		98	9,9

C = Maximum diameter of pump inclusive of cable guard and motor.

Dimensions and Weights

50HZ

Pump Type	Dimensions(mm)			Net Weight(kg)
	A	B	C	Pump
ST-3507	390	RP/NPT 2"	98	3,7
ST-3510	483		98	4,6
ST-3514	607		98	5,7
ST-3520	831		98	7,5
ST-3527	1048		98	9,6
ST-3534	1257		98	11,6
ST-3536	1318		98	12,2
ST-3549	1802		98	15,9

C = Maximum diameter of pump inclusive of cable guard and moter.

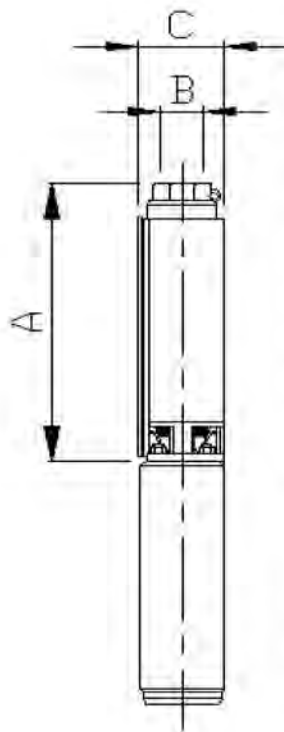

Pump Type	Dimensions(mm)			Net Weight(kg)
	A	B	C	Pump
ST-4004	294	RP/NPT 2"	98	2,8
ST-4006	356		98	3,4
ST-4008	418		98	4,0
ST-4013	573		98	5,5
ST-4017	697		98	6,6
ST-4021	859		98	7,8
ST-4023	921		98	8,4
ST-4032	1238		98	11,0

C = Maximum diameter of pump inclusive of cable guard and moter.

Pump Type	Dimensions(mm)			Net Weight(kg)
	A	B	C	Pump
ST-6007	534	RP/NPT 2"	98	5,3
ST-6010	690		98	6,7
ST-6014	989		98	8,6
ST-6017	1092		98	10,1
ST-6019	1195		98	11,0
ST-6026	1559		98	14,3

C = Maximum diameter of pump inclusive of cable guard and moter.

Pump Type	Dimensions(mm)			Net Weight(kg)
	A	B	C	Pump
ST-8008	676	RP/NPT 2"	98	6,3
ST-8011	880		98	8,1
ST-8013	1013		98	9,3
ST-8015	1149		98	10,5
ST-8020	1489		98	13,5
ST-8026	1810		98 r.	17,5

C = Maximum diameter of pump inclusive of cable guard and motor

6" STAINLESS STEEL SUBMERSIBLE PUMPS



PV 6X SP...

PV 6X SP Stainless steel submersible pumps are made of high quality 304 or 316 corrosion resistant stainless steel. Shafts are made of high strength 431 stainless steel. Pumps are designed for efficient and dependable performance and a long a trouble-free life. Pumps are light in weight and ruggedly constructed for heavy duty applications.

Capacity (m³/h) min 3 max 78
Total head: Max 433 m

APPLICATIONS:

- Potable water supply from deep wells
- Agricultural - Irrigation and livestock watering
- Municipal and industrial water supply
- Pressure boosting
- Mine de-watering
- Fountains, etc.

PUMPED LIQUIDS:

Clean, non corrosive and non-abrasive liquids

OPERATING CONDITIONS:

- Max.ambient temperature (Liquid): 30°C
- Sand content: Max. 50 g/m³

FEATURES:

- Stainless steel construction designed and built for years of trouble free operation
- Heavy duty stainless steel head with built-in check valve for long life and ease of installation
- Mounting specifications are according to NEMA standards
- High quality shaft bearings providing low friction and high wear resistance
- Heavy duty stainless steel impeller & diffusers ensuring optimal performance
- Stainless steel strainer to restrict the entry of sand and other extraneous material

CURRENT AVAILABLE MODELS - MODELES DISPONIBLES

Serie SP 90

Code	Availab/dispo	Hp	Code	Availabl/dispo	Hp
PV 6X SP 90 5	Yes/Oui	4	PV 6X SP 90 27	Yes/Oui	20
PV 6X SP 90 7	Yes/Oui	5.5	PV 6X SP 90 29	Yes/Oui	25
PV 6X SP 90 10	Yes/Oui	7.5	PV 6X SP 90 31	No	25
PV 6X SP 90 13	Yes/Oui	10	PV 6X SP 90 33	Yes/Oui	25
PV 6X SP 90 17	Yes/Oui	12.5	PV 6X SP 90 36	No	30
PV 6X SP 90 20	Yes/Oui	15	PV 6X SP 90 38	Yes/Oui	30
PV 6X SP 90 24	No	17.5	PV 6X SP 90 40	Yes/Oui	30

Serie SP 150

Code	Availab/dispo	Hp	Code	Availabl/dispo	Hp
PV 6X SP 150 4	Yes/Oui	5	PV 6X SP 150 20	Yes/Oui	25
PV 6X SP 150 5	No	7,5	PV 6X SP 150 21	Yes/Oui	25
PV 6X SP 150 6	Yes/Oui	7,5	PV 6X SP 150 22	No	30
PV 6X SP 150 7	No	10	PV 6X SP 150 23	No	30
PV 6X SP 150 8	Yes/Oui	10	PV 6X SP 150 24	No	30
PV 6X SP 150 9	Yes/Oui	12,5	PV 6X SP 150 25	Yes/Oui	30
PV 6X SP 150 10	Yes/Oui	12,5	PV 6X SP 150 26	Yes/Oui	30
PV 6X SP 150 11	Yes/Oui	15	PV 6X SP 150 27	No	35
PV 6X SP 150 12	Yes/Oui	15	PV 6X SP 150 28	No	35
PV 6X SP 150 13	Yes/Oui	15	PV 6X SP 150 29	Yes/Oui	35
PV 6X SP 150 14	No	17,5	PV 6X SP 150 30	No	35
PV 6X SP 150 15	Yes/Oui	20	PV 6X SP 150 31	No	35
PV 6X SP 150 16	Yes/Oui	20	PV 6X SP 150 32	Yes/Oui	40
PV 6X SP 150 17	Yes/Oui	20	PV 6X SP 150 33	No	40
PV 6X SP 150 18	No	25	PV 6X SP 150 34	No	40
PV 6X SP 150 19	Yes/Oui	25	PV 6X SP 150 35	Yes/Oui	40

Serie SP 230

Code	Availab/dispo	Hp	Code	Availab/dispo	Hp
PV 6X SP 230 4C	Yes/Oui	7.5	PV 6X SP 230 14	No	30
PV 6X SP 230 4	Yes/Oui	10	PV 6X SP 230 15	Yes/Oui	30
PV 6X SP 230 5	Yes/Oui	10	PV 6X SP 230 16	No	35
PV 6X SP 230 6	No	12,5	PV 6X SP 230 17	No	35
PV 6X SP 230 7	Yes/Oui	15	PV 6X SP 230 18	No	40
PV 6X SP 230 8	No	15	PV 6X SP 230 19	Yes/Oui	40
PV 6X SP 230 9	No	20	PV 6X SP 230 20	No	40
PV 6X SP 230 10	Yes/Oui	20	PV 6X SP 230 21	No	50
PV 6X SP 230 11	No	25	PV 6X SP 230 22	Yes/Oui	50
PV 6X SP 230 12	Yes/Oui	25	PV 6X SP 230 23	No	50
PV 6X SP 230 13	No	30	PV 6X SP 230 24	Yes/Oui	50

Serie SP 300

Code	Availabl/dispo	Hp	Code	Availabil/dispo	Hp
PV 6X SP 300 2A	No	4	PV 6X SP 300 12	Yes/Oui	30
PV 6X SP 300 2	Yes/Oui	5	PV 6X SP 300 13	No	35
PV 6X SP 300 3	No	7,5	PV 6X SP 300 14	Yes/Oui	35
PV 6X SP 300 4	Yes/Oui	10	PV 6X SP 300 15	No	35
PV 6X SP 300 5	Yes/Oui	12,5	PV 6X SP 300 16	Yes/Oui	40
PV 6X SP 300 6	Yes/Oui	15	PV 6X SP 300 17	No	50
PV 6X SP 300 7	No	17,5	PV 6X SP 300 18	No	50
PV 6X SP 300 8	Yes/Oui	20	PV 6X SP 300 19	No	50
PV 6X SP 300 9	Yes/Oui	25	PV 6X SP 300 20	Yes/Oui	50
PV 6X SP 300 10	Yes/Oui	25	PV 6X SP 300 21	No	50
PV 6X SP 300 11	No	30	PV 6X SP 300 22	Yes/Oui	50

ORLANDO srl

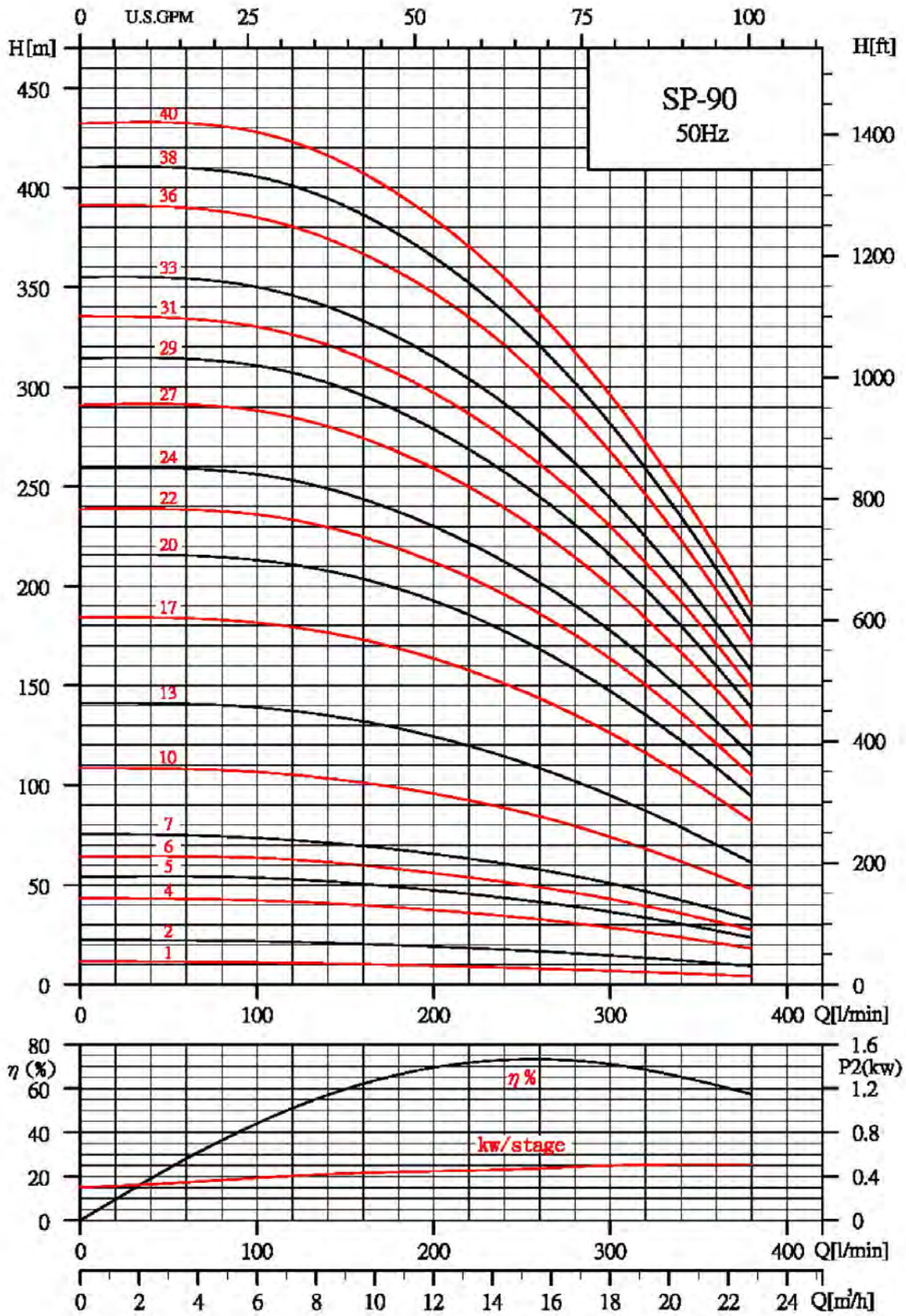

Pump Type	Motor		Max.current		Q capacity 2900 rpm								
	P2		Amp		m³/h 1/min	3	6	9	12	15	18	21	23
	KW	HP	220V	380V		50	100	150	200	250	300	350	383
SP 90-1	0.55	0.75	2.6	1.5	HEAD IN METERS	11.5	11	10.5	9.5	8	7	6	4
SP 90-2	1.1	1.5	5.2	3.0		22	21.5	20.5	19	17.5	15	12	9
SP 90-4	2.2	3	9.5	5.5		42.5	42	40.5	38	33	28.5	23	18
SP 90-5	3	4	13.3	7.7		53	52	51	47.5	42.5	37	29	22
SP 90-6	3.7	5	15.4	8.9		64	63	60	56	50	43	34	27
SP 90-7	4	5.5	17	10.4		75	74	71	66	59	51	40	32
SP 90-10	5.5	7.5	22.2	12.8		108	107	102	95	86	74	59	49
SP 90-13	7.5	10	28.5	16.5		141	139	133	124	112	95	75	60
SP 90-17	9.3	12.5	36	20.9		184	182	175	163	147	126	100	80
SP 90-20	11	15	41.8	24.2		216	213	206	192	175	147	116	95
SP 90-22	13	17.5	50	29		239	237	228	212	191	163	130	105
SP 90-24	13	17.5	50	29		260	257	247	230	208	178	140	115
SP 90-27	15	20	55	32		292	288	277	260	234	200	158	128
SP 90-29	18.5	25	69	40		315	311	300	279	251	215	170	138
SP 90-31	18.5	25	69	40		335	330	318	298	269	230	181	148
SP 90-33	18.5	25	69	40		355	350	337	315	285	243	191	157
SP 90-36	22	30	81	47		391	385	371	348	313	268	210	170
SP 90-38	22	30	81	47		410	405	390	365	330	282	222	180
SP 90-40	22	30	81	47		433	428	412	384	346	296	235	190

DIMENSIONS AND WEIGHTS

Pump Type	Dimensions(mm)						Net Weight(Kg)	
	A	B	C	D	E*	E**	Pump	Motor
SP 90-1	613	270	343	RP 2 1/2"	131		5	9.5
SP 90-2	701	298	403		131		6.4	11
SP 90-4	932	408	524		131		9.3	16
SP 90-5	1034	449	585		131		10.8	19
SP 90-6	1208	563	645		131		12.2	25
SP 90-7	1269	563	706		131		13.7	25
SP 90-10	1501	614	887		131		18	48
SP 90-13	1715	646	1069		142	142	22.4	52
SP 90-17	2022	711	1311		142	142	28.2	58
SP 90-20	2203	711	1492		142	142	32.5	58
SP 90-22	2389	776	1613		142	142	35.4	64
SP 90-24	2510	776	1734		142	142	38.3	64
SP 90-27	2692	776	1916		142	142	42.7	64
SP 90-29	2878	841	2037		142	142	45.6	70
SP 90-31	2999	841	2158		142	142	48.5	70
SP 90-33	3120	841	2279		142	142	51.4	70
SP 90-36	3366	906	2460		142	142	55.7	76
SP 90-38	3487	906	2581		142	142	58.6	76
SP 90-40	3608	906	2702		142	142	61.5	76

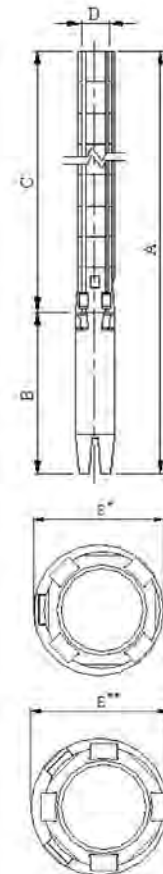

E*: Maximum diameter of pump with one motor cable

E**: Maximum diameter of pump with two motor cable

ORLANDO srl

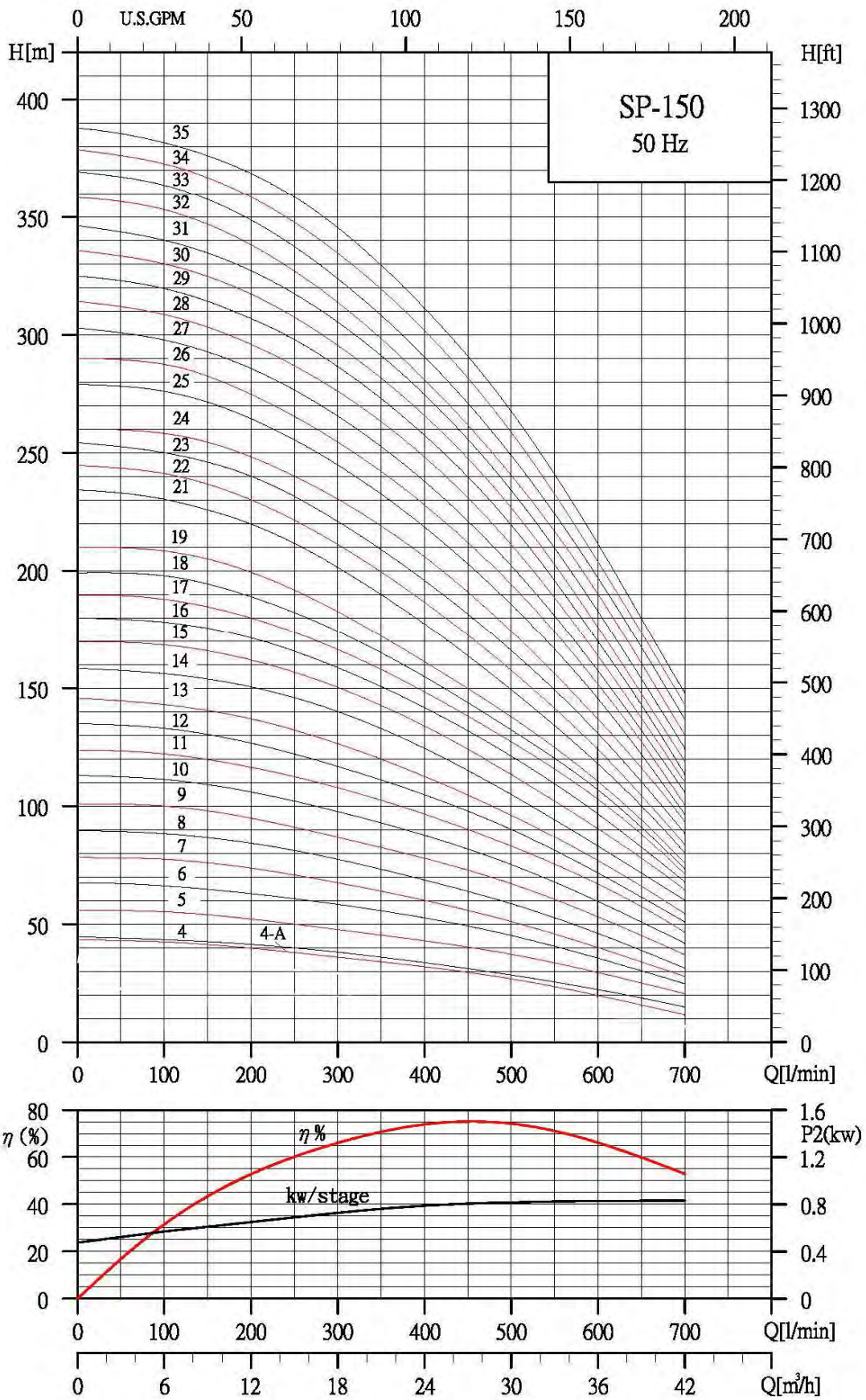

Pump Type	Motor P2		Max.current Amp		Q capacity 2900 rpm													
	KW	HP	220V	380V	m ³ /h 1/min	6	9	12	15	18	21	24	27	30	33	36	39	42
						100	150	200	250	300	350	400	450	500	550	600	650	700
SP150-2	2.2	3	9.5	5.5	HEAD IN METERS	23	22	21	20	19	18	17	16	15	13	11	9	6
SP150-3	3	4	13.3	7.7		33	32	31	30	29	28	26	24	22	20	17	14	11
SP150-4	3.7	5	15.4	8.9		43	42	41	40	38	36	34	31	28	26	23	19	15
SP150-6	5.5	7.5	22.2	12.8		67	64	62	60	58	56	52	49	45	40	36	30	25
SP150-8	7.5	10	28.5	16.5		88	87	84	81	78	73	68	64	58	53	46	38	31
SP150-11	11	15	41.8	24.2		122	120	117	112	108	102	97	90	83	76	67	57	47
SP150-13	11	15	41.8	24.2		143	140	137	132	127	120	113	105	97	87	77	66	55
SP150-15	15	20	55	32		168	166	162	157	150	142	134	124	113	102	90	77	65
SP150-17	15	20	55	32		188	185	180	173	167	158	148	138	127	116	103	88	71
SP150-19	18.5	25	69	40		208	205	199	192	182	172	161	150	137	125	110	94	77
SP150-21	18.5	25	69	40		230	226	220	212	202	190	177	164	149	134	117	100	80
SP150-24	22	30	81	47		258	254	248	240	230	219	207	191	175	156	137	117	93
SP150-26	22	30	81	47		287	282	275	266	255	242	227	212	194	173	152	127	100
SP150-29	26	35	96	56		319	314	307	298	287	273	257	240	220	196	170	143	113
SP150-32	30	40	111	64		353	347	338	327	313	298	281	261	240	217	190	160	130
SP150-35	30	40	111	64		382	377	368	358	346	329	311	290	267	240	211	180	148

DIMENSIONS AND WEIGHTS

Pump Type	Dimensions(mm)						Net Weight(kg)	
	A	B	C	D	E*	E**	Pump	Motor
SP150-2	870	408	462	NPT / RP 3"	131		8.4	16
SP150-3	1007	449	558		131		10.1	19
SP150-4	1217	563	654		131		11.8	25
SP150-6	1460	614	846		131		15.2	48
SP150-8	1684	646	1038		142	142	18.6	52
SP150-11	2037	711	1326		142	142	23.6	58
SP150-13	2229	711	1518		142	142	27	58
SP150-15	2486	776	1710		142	142	30.4	64
SP150-17	2678	776	1902		142	142	33.8	64
SP150-19	2935	841	2094		142	142	37.2	70
SP150-21	3127	841	2286		142	142	40.6	70
SP150-24	3480	906	2574		142	142	45.6	76
SP150-26	3672	906	2766		142	142	49	76
SP150-29	4090	1036	3054		142	142	54.1	92
SP150-32	4378	1036	3342		142	142	59.2	92
SP150-35	4666	1036	3630		142	142	64.3	92

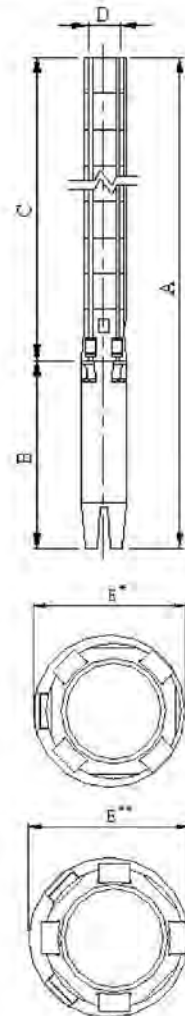

E*: Maximum diameter of pump with one motor cable

E**: Maximum diameter of pump with two motor cable

ORLANDO srl

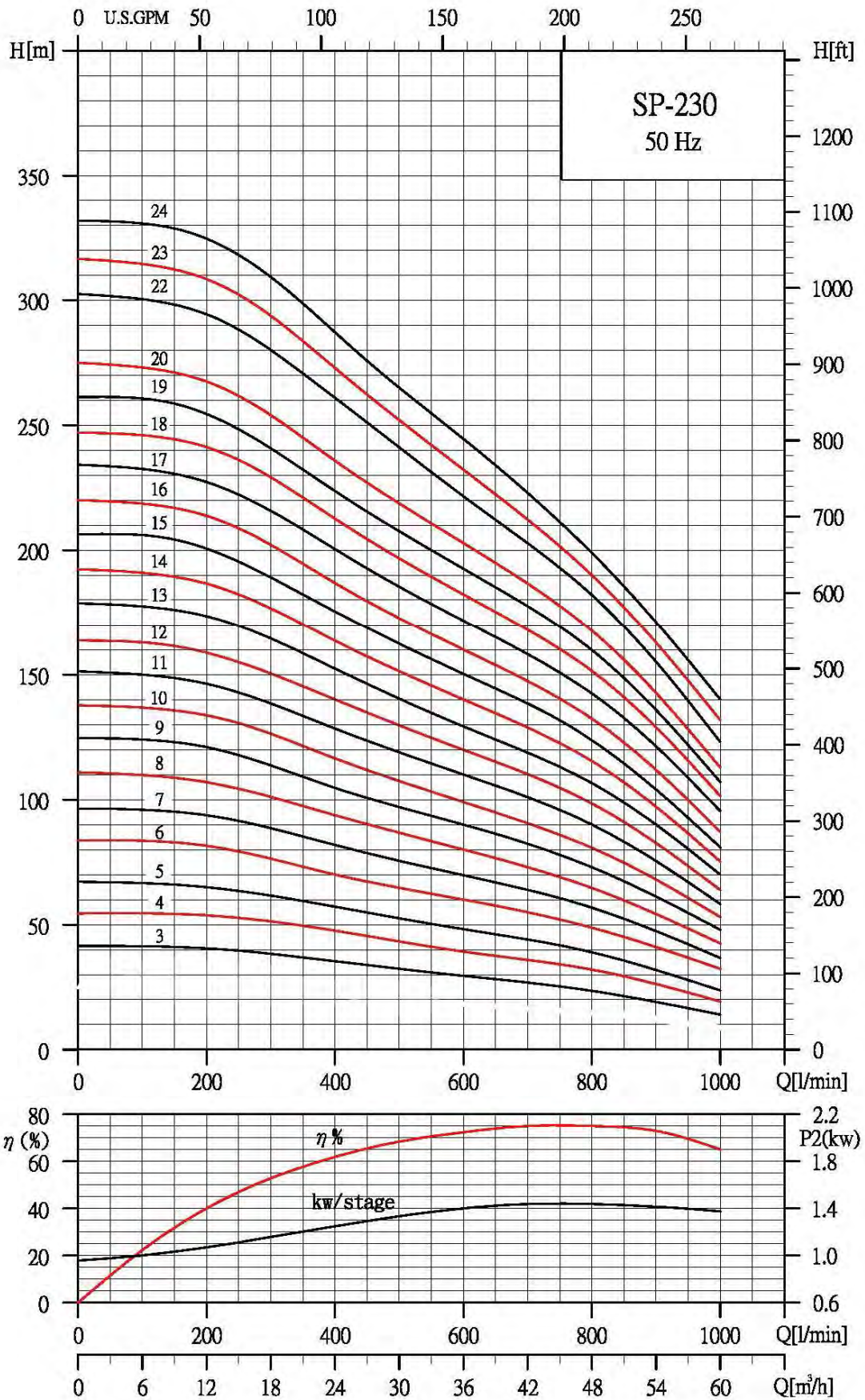

SELECTION CHART

50 HZ

Pump Type	Motor P2		Max.current Amp		Q capacity 2900 rpm												
	KW	HP	220V	380V	m ³ /h 1/min	12	15	18	21	24	27	30	36	42	48	54	60
						200	250	300	350	400	450	500	600	700	800	900	1000
SP230-2	3	4	13.3	7.7	HEAD IN METERS	24	23.5	23	22.5	22	21	20	18	17	15	12	9
SP230-3C	3.7	5	15.4	8.9		35	34	32	31	29	28	27	24	22	19	15	10
SP230-3	5.5	7.5	22.2	12.8		40	39	38	37	35	34	33	29	27	23	18	14
SP230-4C	5.5	7.5	22.2	12.8		49	47	46	45	43	41	39	36	32	28	23	17
SP230-5	7.5	10	28.5	16.5		65	63	61	59	57	55	53	48	44	39	32	24
SP230-7	11	15	41.8	24.2		94	92	88	85	82	79	76	70	64	57	47	37
SP230-8C	11	15	41.8	24.2		100	98	95	92	88	85	82	76	69	61	51	39
SP230-10	15	20	55	32		133	130	127	122	117	112	107	98	90	80	67	53
SP230-12	18.5	25	69	40		158	155	150	145	140	135	130	120	110	98	83	64
SP230-15	22	30	81	47		200	195	189	183	177	169	163	150	138	124	105	81
SP230-17	26	35	96	56		227	222	215	208	200	193	186	172	158	143	121	96
SP230-19	30	40	111	64		254	248	241	233	224	216	208	193	178	160	136	107
SP230-22	40	50	138	80		294	288	280	270	260	251	241	222	203	183	155	123
SP230-24	40	50	138	80		325	317	309	298	287	276	265	244	223	199	171	140

DIMENSIONS AND WEIGHTS

Pump Type	Dimensions(mm)						Net Weight(kg)	
	A	B	C	D	E*	E**	Pump	Motor
SP230-2	945	449	496	NPT / RP 3"	146		9.2	19
SP230-3-C	1172	563	609		146		11.5	25
SP230-3	1223	614	609		146		11.5	48
SP230-4-C	1336	614	722		146		13.8	48
SP230-5	1481	646	835		149	152	16	52
SP230-7	1772	711	1061		149	152	20.6	58
SP230-8-C	1885	711	1174		149	152	22.9	58
SP230-10	2176	776	1400		149	152	27.4	64
SP230-12	2467	841	1626		149	152	32	70
SP230-15	2871	906	1965		149	152	38.8	76
SP230-17	3227	1036	2191		149	152	43.4	92
SP230-19	3453	1036	2417		149	152	47.9	92
SP230-22	4161	1405	2756		149	152	54.8	136
SP230-24	4387	1405	2982		149	152	59.3	136

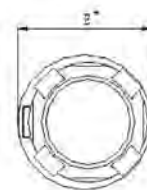
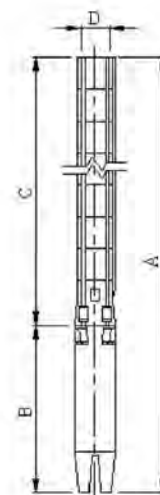

E*: Maximum diameter of pump with one motor cable

E**: Maximum diameter of pump with two motor cable

ORLANDO srl

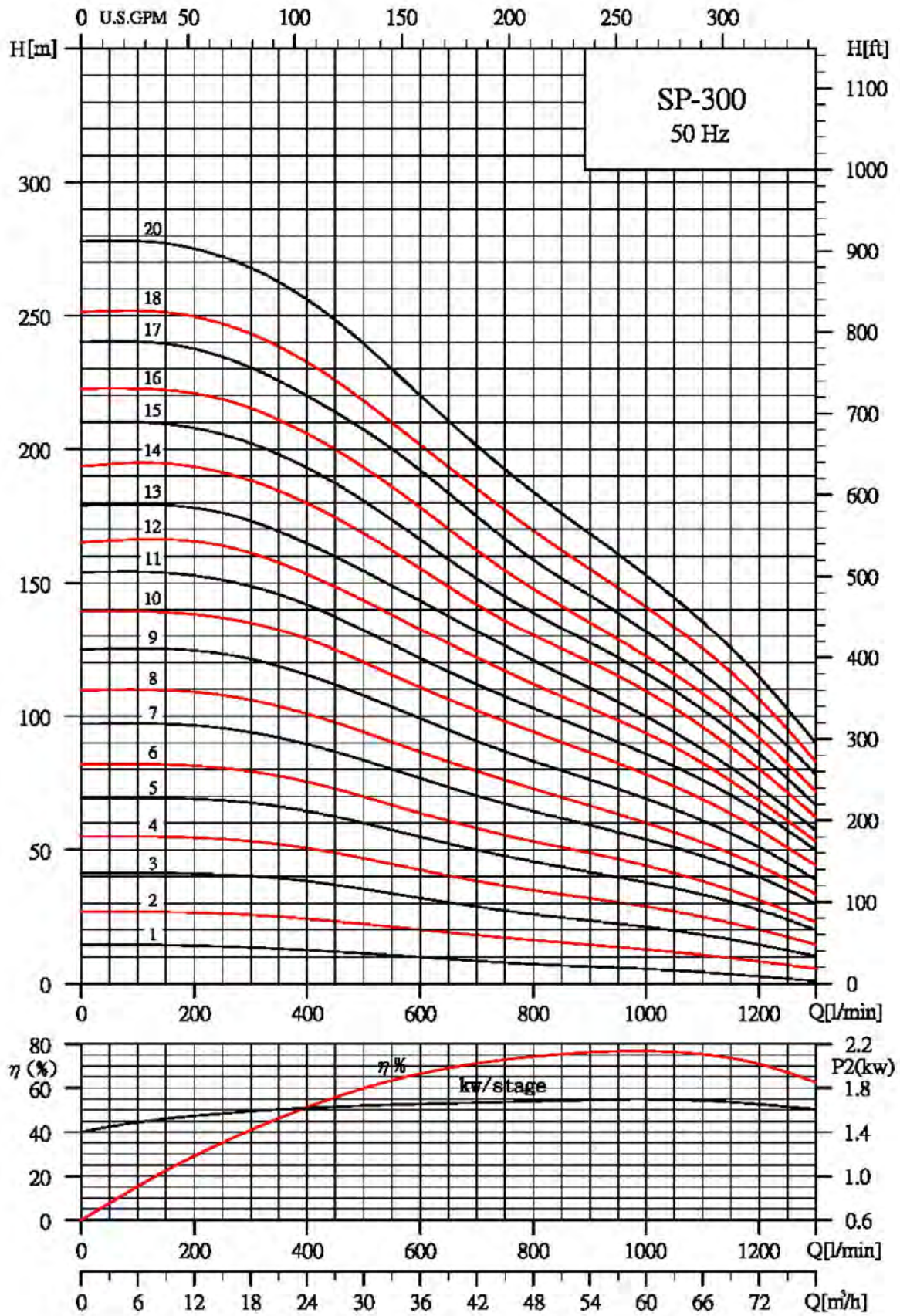

SP 300-22

Motor Specification			Pump Specification		
Rating:50HP	Phase:3	Voltage:380V	Rating Head:175.1m	Outlet ID: 3 in	Liquid:water
Model:	Pole:2P	Current:82A	Rating Flow:984.4L/min	Stage: 22	Liquid Poise: 1
Maker:Franklin	Freq.:50Hz	Eff.:83%	Rating Eff.:78.71%	Type:SP300-22	Temper.: 15 C
Serial No:	Insulation:F	S.F:1	Customer:	Serial No.:50-22	

No.	Q(L/min)	H(m)	Volt	AMP	kw	HP	Eff(%)
1.00	0.00	305.84	379.7	66.46	36.70	41.19	0.00
2.00	168.20	306.64	379.0	71.53	40.10	44.94	25.13
3.00	235.80	304.56	378.8	73.36	41.30	46.35	33.92
4.00	314.40	297.52	378.5	75.43	42.60	47.76	42.88
5.00	407.00	283.72	378.4	76	43.00	48.15	52.51
6.00	500.00	267.48	378.4	76.36	43.20	48.34	60.58
7.00	581.40	249.92	378.6	75.66	42.80	47.96	66.34
8.00	660.00	233.48	378.6	75.43	42.70	47.86	70.50
9.00	740.20	216.40	378.7	75.46	42.70	47.86	73.28
10.00	822.00	202.80	378.6	75.26	42.60	47.76	76.42
11.00	918.00	187.72	378.8	75.83	43.00	48.15	78.37
12.00	984.40	175.12	378.9	75.59	42.80	47.96	78.71
13.00	1053.60	161.60	378.9	75.06	42.50	47.67	78.21
14.00	1115.20	148.44	378.9	74.66	42.20	47.37	76.51
15.00	1189.40	133.80	379.0	73.86	41.70	46.83	74.42
16.00	1238.00	120.80	379.2	72.89	41.10	46.12	71.00
17.00	1280.00	107.48	379.4	71.96	40.50	45.41	66.33
18.00	1325.60	95.56	379.5	71.06	39.90	44.71	62.04
19.00	1355.80	83.96	379.6	70	39.20	43.89	56.79
20.00	1387.60	73.92	379.5	69.23	38.70	43.33	51.83
21.00	1416.60	64.84	379.8	68.3	38.10	42.69	47.11
22.00	1438.60	57.16	380.0	67.33	37.50	42.05	42.82
23.00	1454.60	50.48	380.0	66.63	37.00	41.51	38.73
24.00	1473.20	43.92	380.3	66	36.60	41.08	34.48
25.00	1501.80	33.16	380.5	64.73	35.80	40.22	27.11
26.00	1518.40	26.04	380.7	63.9	35.20	39.57	21.88
27.00	1529.00	20.24	380.8	63.26	34.70	39.02	17.37
28.00	1539.00	16.08	380.9	62.76	34.40	38.69	14.00
29.00	1546.60	12.84	381.0	62.46	34.10	38.36	11.33
30.00	1552.00	10.52	380.9	62.16	33.90	38.14	9.37
31.00	1557.00	8.88	381.1	62.06	33.90	38.14	7.94
32.00	1564.20	4.84	381	61.63	33.60	37.82	4.38

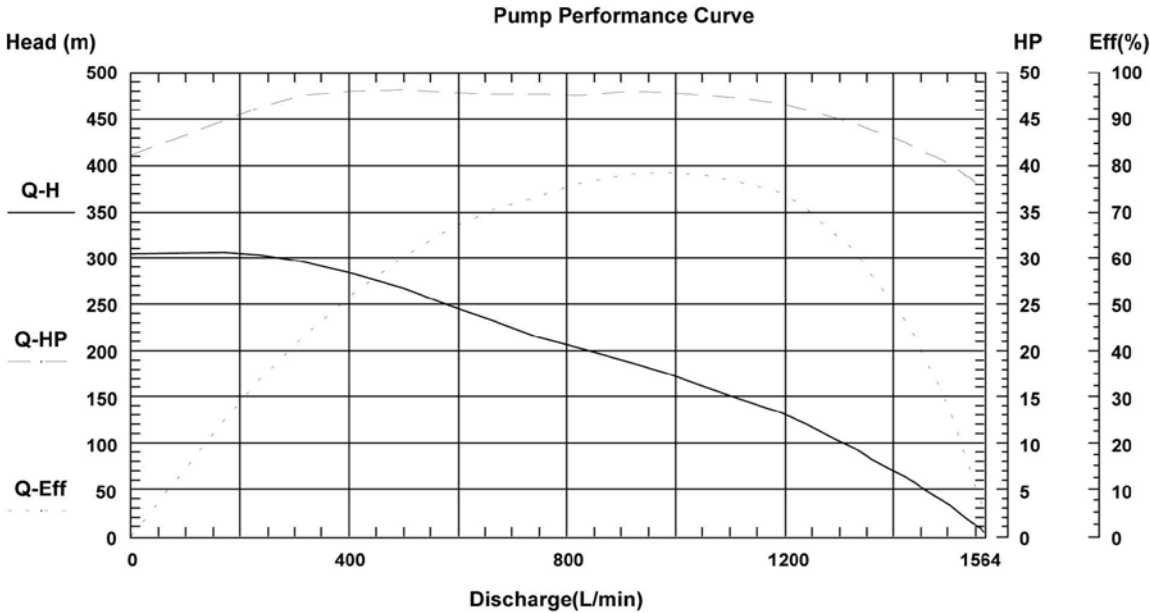

SELECTION CHART

50 HZ

Pump Type	Motor		Max.current		Q capacity 2900 rpm													
	P2		Amp		m ³ /h 1/min	18	123	24	27	30	36	42	48	54	60	66	72	78
	KW	HP	220V	380V		300	123	400	450	500	600	700	800	900	1000	1100	1200	1300
SP300-1	2.2	3	9.5	5.5	13	12.5	12	11.5	11	10	8	7	6	5	4	2	1	
SP300-2	3.7	5	15.4	8.9	26	25	24	23	22	20	18	16	14	13	11	8	5	
SP300-3	5.5	7.5	22.2	12.8	40	39	38	37	36	32	28	26	24	22	18	14	10	
SP300-4	7.5	10	28.5	16.5	53	52	51	48	47	43	38	35	32	28	25	20	14	
SP300-5	9.3	12.5	36	20.9	67	66	64	62	60	55	50	46	42	38	33	27	19	
SP300-6	11	15	41.8	24.2	79	78	76	73	70	64	58	53	48	44	38	32	23	
SP300-7	13	17.5	50	29	94	92	89	86	84	77	70	64	59	54	47	40	29	
SP300-8	15	20	55	32	106	104	101	97	94	87	80	73	67	60	53	44	33	
SP300-9	18.5	25	69	40	122	118	116	112	108	99	91	83	76	69	61	51	38	
SP300-10	18.5	25	69	40	135	132	128	125	120	111	102	95	87	78	68	57	45	
SP300-11	22	30	81	47	148	146	142	137	132	122	112	103	95	86	76	64	49	
SP300-12	22	30	81	47	162	157	153	148	143	133	122	112	103	94	83	68	53	
SP300-13	26	35	96	56	173	169	165	160	155	143	132	121	110	100	87	73	57	
SP300-14	26	35	96	56	188	184	180	175	168	156	142	130	120	109	96	80	63	
SP300-15	26	35	96	56	203	197	193	187	180	166	152	138	127	116	103	86	67	
SP300-16	30	40	111	64	216	211	206	200	193	178	162	148	135	123	108	92	72	
SP300-17	40	50	138	80	230	226	220	214	207	192	175	158	145	132	116	97	78	
SP300-18	40	50	138	80	243	238	233	226	218	202	185	170	155	141	126	107	83	
SP300-20	40	50	138	80	267	263	256	248	239	220	201	184	168	153	136	115	90	

HEAD IN METERS

DIMENSIONS AND WEIGHTS

Pump Type	Dimensions(mm)						Net Weight(kg)	
	A	B	C	D	E*	E**	Pump	Motor
SP300-1	832	449	383	NPT / RP 4"	146		6.9	19
SP300-2	1059	563	496		146		9.2	25
SP300-3	1223	614	609		146		11.5	48
SP300-4	1368	646	722		149	152	13.7	52
SP300-5	1546	711	835		149	152	16	58
SP300-6	1659	711	948		149	152	18.3	58
SP300-7	1837	776	1061		149	152	20.6	64
SP300-8	1950	776	1174		149	152	22.9	64
SP300-9	2128	841	1287		149	152	25.1	70
SP300-10	2241	841	1400		149	152	27.4	70
SP300-11	2419	906	1513		149	152	29.7	76
SP300-12	2532	906	1626		149	152	32	76
SP300-13	2775	1036	1739		149	152	34.3	92
SP300-14	2888	1036	1852		149	152	36.5	92
SP300-15	3001	1036	1965		149	152	38.8	92
SP300-16	3114	1036	2078		149	152	41.1	92
SP300-17	3596	1405	2191		149	152	43.4	136
SP300-18	3709	1405	2304		149	152	45.7	136
SP300-20	3935	1405	2530		149	152	50.2	136

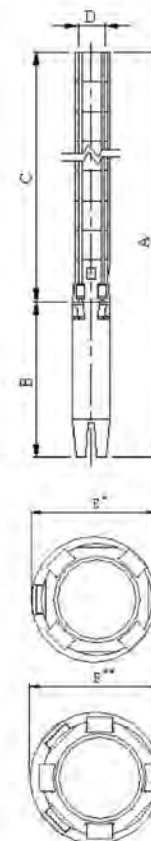

4" SUBMERSIBLE MULTISTAGE CENTRIFUGAL PUMPS



PS CO 4X...:



PS CO 4S...:

Description

Submersible multistage centrifugal pumps for 4" wells, particularly suitable for water rising and distribution installations requiring very high pressures and flow rates.

Applications

Water plants and systems for residential and industrial use, for continuous or intermittent duty operation.
Pressurizing system.
Irrigation plants.

Design features

Motor coupling flange and discharge head are made in brass (OT 58) or in stainless steel (AISI 304).
Incorporated non-return check valve for all pump types in easily removable.
Impellers and diffusers in non toxic polycarbonate (Lexan), diffusers body in stainless steel (AISI 304) for type 6 - 10 - 14 - 24.
Shell, pump shaft, coupling, cable shield, suction screen and all screws are in stainless steel.
Pump flanges for coupling with motors are made according to NEMA standards.
Max \varnothing pump 96 mm.

ORLANDO srl

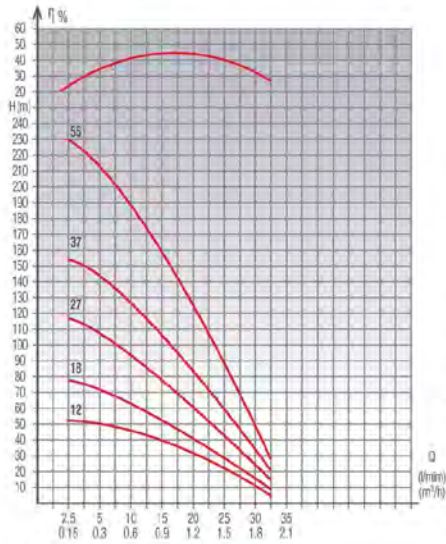

Codice Code	Motore Motor		Q Portata - Capacity - Debit						Dimensioni e Pesì Dimension and Weight Dimension et Masses						
	kw	HP	m³/h	0.15	0.3	0.6	0.9	1.2	1.5	1.8	OT	INOX	OTR	OTF	INOX
PS CO 4S 2 12	0.25	0.33	53	51	46	40	33	24	13						
PS CO 4S 2 18	0.37	0.5	78	75	67	57	46	33	18						
PS CO 4S 2 27	0.55	0.75	115	111	99	85	67	48	26						
PS CO 4S 2 37	0.75	1	153	149	133	114	90	63	35						
PS CO 4S 2 55	1.1	1.5	231	220	196	168	134	93	49						

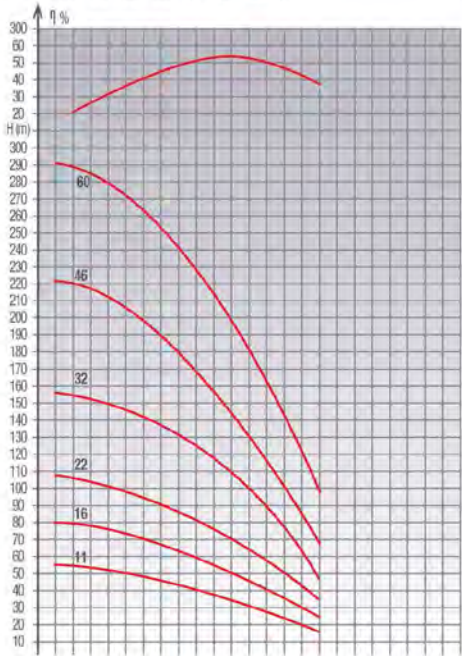

Codice Code	Motore Motor		Q Portata - Capacity - Debit								Dimensioni e Pesì Dimension and Weight Dimension et Masses					
	kw	HP	m³/h	0.3	0.6	0.9	1.2	1.5	1.8	2.1	2.4	OT	INOX	OTR	OTF	INOX
PS CO 4S 3 11	0.37	0.5	54	51	48	44	40	34	28	20						
PS CO 4S 3 16	0.55	0.75	78	75	70	65	58	49	39	29						
PS CO 4S 3 22	0.75	1	106	102	96	89	80	69	57	40						
PS CO 4S 3 32	1.1	1.5	153	147	138	127	115	99	79	58						
PS CO 4S 3 46	1.5	2	218	210	198	183	162	137	110	80						
PS CO 4S 3 60	2.2	3	284	274	262	243	218	188	154	116						

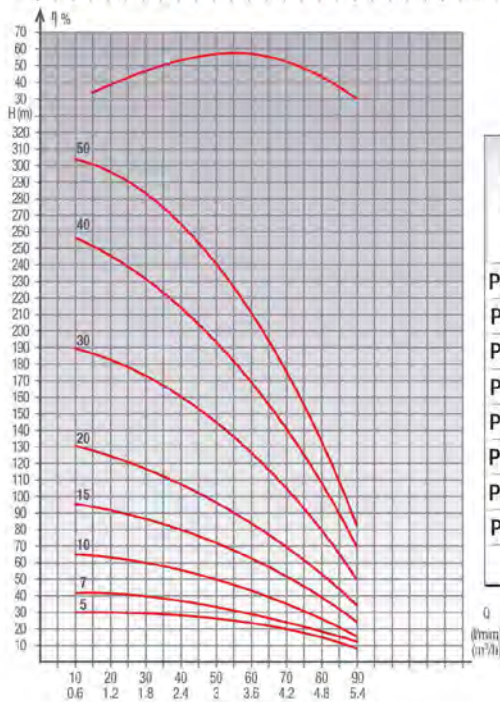

Codice Code	Motore Motor		Q Portata - Capacity - Debit									Dimensioni e Pesì Dimension and Weight Dimension et Masses					
	kw	HP	m³/h	0.9	1.2	1.8	2.4	3	3.6	4.2	4.8	5.4	OT	INOX	OTR	OTF	INOX
PS CO 4S 6 5	0.37	0.5	30	29	27	25	23	21	17	13	9						
PS CO 4S 6 7	0.55	0.75	42	41	39	36	34	30	26	20	12						
PS CO 4S 6 10	0.75	1	62	58	54	50	47	42	35	26	16						
PS CO 4S 6 15	1.1	1.5	93	91	85	79	72	61	52	39	26						
PS CO 4S 6 20	1.5	2	124	122	115	105	96	84	69	52	34						
PS CO 4S 6 30	2.2	3	182	179	168	154	142	124	104	78	49						
PS CO 4S 6 40	3	4	242	236	223	207	187	163	136	102	68						
PS CO 4S 6 50	4	5.5	303	298	279	259	238	208	172	130	83						

ORLANDO srl

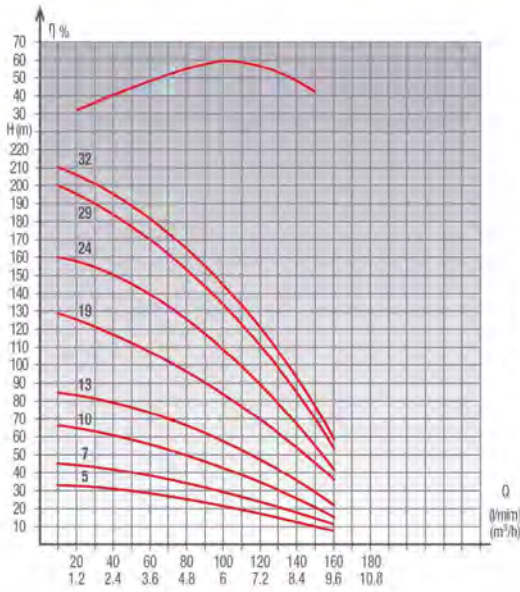

Codice Code	Motore Motor		Q Portata - Capacity - Debit	Dimensioni e Pesì Dimension and Weight Dimension et Masses				
	kw	HP		m³/h	mm		kg	
					OT	INOX	OTR	OTF
PS CO 4S 10 5	0.55	0.75	20 40 60 80 100 120 140 160	525	545	4.2	4.7	3.6
PS CO 4S 10 7	0.75	1	20 40 60 80 100 120 140 160	630	650	4	5.5	4.2
PS CO 4S 10 10	1.1	1.5	20 40 60 80 100 120 140 160	790	810	5.7	6.6	5.1
PS CO 4S 10 13	1.5	2	20 40 60 80 100 120 140 160	950	970	6.6	7.7	6
PS CO 4S 10 19	2.2	3	20 40 60 80 100 120 140 160	1265	1285	8.5	10.1	7.9
PS CO 4S 10 24	3	4	20 40 60 80 100 120 140 160	1585	1605	10.7	12.8	10.1
PS CO 4S 10 29	3.7	5	20 40 60 80 100 120 140 160	1850	1870	12.2	14.6	11.6
PS CO 4S 10 32	4	5.5	20 40 60 80 100 120 140 160	2010	2030	13.1	15.8	12.5

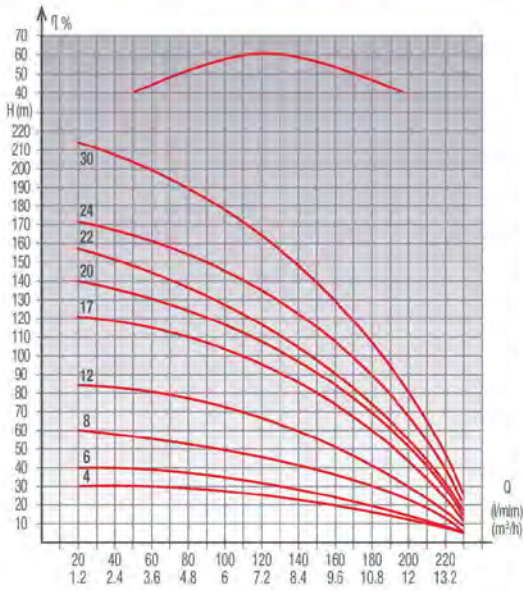

Codice Code	Motore Motor		Q Portata - Capacity - Debit	Dimensioni e Pesì Dimension and Weight Dimension et Masses				
	kw	HP		m³/h	mm		kg	
					OT	INOX	OTR	OTF
PS CO 4S 14 4	0.75	1	20 40 60 80 100 140 180 220	475	495	3.9	4.3	3.3
PS CO 4S 14 6	1.1	1.5	20 40 60 80 100 140 180 220	580	600	4.5	5.1	3.9
PS CO 4S 14 8	1.5	2	20 40 60 80 100 140 180 220	685	705	5.1	5.9	4.5
PS CO 4S 14 12	2.2	3	20 40 60 80 100 140 180 220	895	915	6.3	7.4	5.7
PS CO 4S 14 17	3	4	20 40 60 80 100 140 180 220	1160	1180	7.9	9.3	7.3
PS CO 4S 14 20	3.7	5	20 40 60 80 100 140 180 220	1375	1395	9.5	11.2	8.9
PS CO 4S 14 22	4	5.5	20 40 60 80 100 140 180 220	1480	1500	10.1	12	9.5
PS CO 4S 14 24	4	5.5	20 40 60 80 100 140 180 220	1585	1605	10.7	12.8	10.1
PS CO 4S 14 30	5.5	7.5	20 40 60 80 100 140 180 220	1905	1925	12.5	15	11.9

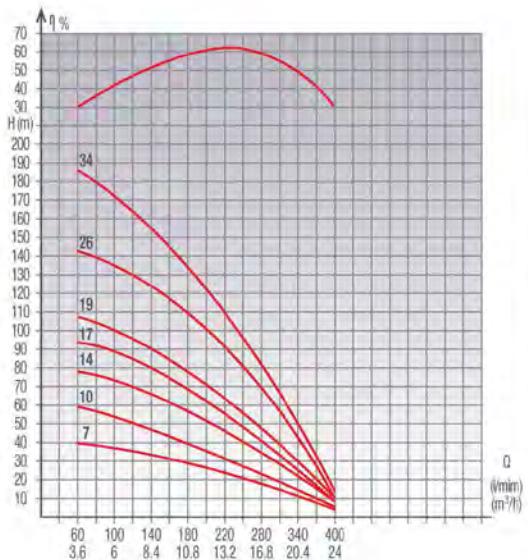

Codice Code	Motore Motor		Q Portata - Capacity - Debit	Dimensioni e Pesì Dimension and Weight Dimension et Masses				
	kw	HP		m³/h	mm		kg	
					OT	INOX	OTR	OTF
PS CO 4S 24 7	1.5	2	60 100 140 180 220 280 340 400	820	840	5.9	6.9	5.3
PS CO 4S 24 10	2.2	3	60 100 140 180 220 280 340 400	1055	1075	7.3	8.6	6.7
PS CO 4S 24 14	3	4	60 100 140 180 220 280 340 400	1435	1455	9.5	11.4	8.9
PS CO 4S 24 17	3.7	5	60 100 140 180 220 280 340 400	1665	1685	11	13.1	10.4
PS CO 4S 24 19	4	5.5	60 100 140 180 220 280 340 400	1825	1845	12	14.4	11.4
PS CO 4S 24 26	5.5	7.5	60 100 140 180 220 280 340 400	2435	2455	15.6	18.9	15
PS CO 4S 24 34	7.5	10	60 100 140 180 220 280 340 400	3130	3150	19.3	23.5	18.7

ORLANDO srl

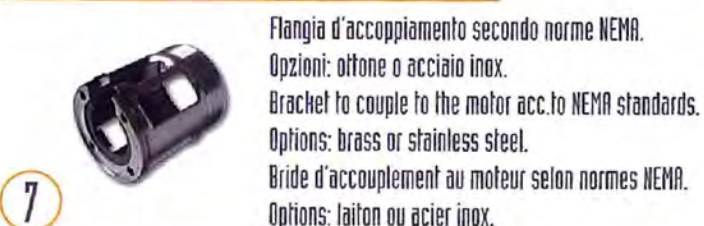
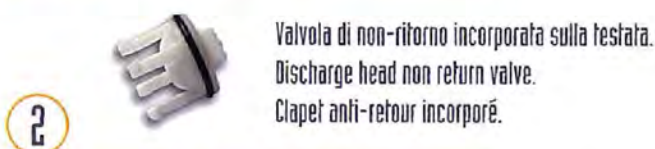

6''



SUBMERSIBLE MULTISTAGE CENTRIFUGAL PUMPS 6'' WELLS

DESCRIPTION

Submersible multistage centrifugal pumps for 6'' wells, particularly suitable for water rising and distribution installations requiring very high pressures and flow rates.

APPLICATIONS

Water plants and systems for residential and industrial use, for continuous or intermittent duty operation. Pressurizing system

DESIGN FEATURES

Motor coupling flange and discharge head are made in brass (OT58). Incorporated non-return check valve for all pump types in easily removable. Impellers and diffusers in Noryl, diffusers body in stainless steel (AISI 304).

Shell, pump shaft, coupling, cable shield, suction screen and all screws are in stainless steel.

Pump flanges for coupling with motors are made according to NEMA standards.

Max ø pump 145 mm



Bocca di mandata in ottone.
Brass discharge head.
Pièce de refoulement en laiton.



Valvola di non-ritorno incorporata sulla testata.
Discharge head non return valve.
Clapet anti-refoulement incorporé.



Bronzina superiore in bronzo o, a richiesta, in gomma antisabbia.
Upper bush made in bronze or, upon request, in anti-sand rubber.
Palier supérieur en bronze ou sur demande en caoutchouc anti sable.



Giranti e diffusori in Noryl con anelli di rasamento in acciaio inox. Alto rendimento.
Noryl made impellers and diffuser with stainless steel wear-inserts. High efficiency.
Roues et diffuseurs en Noryl avec anneaux d'usure en inox. Haut rendement.



Camicia in acciaio inox.
Stainless steel shell.
Chemise en acier inox.



Filtro in acciaio inox.
Stainless steel strainer.
Crepine en acier inox.



Flangia d'accoppiamento secondo norme NEMA.
Bracket to couple to the motor acc. to NEMA standards.
Bride d'accouplement au moteur selon normes NEMA.



ORLANDO srl

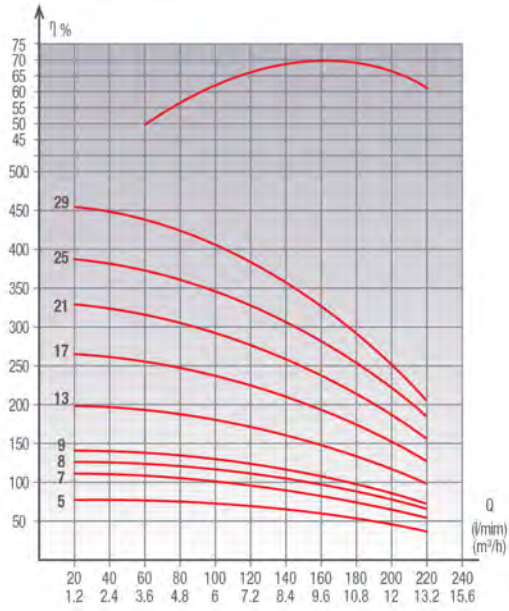

Tipo Type Type	Motore Motor Moteur		Q Portata - Capacity - Debit										Dimensioni e Pesì Dimension and Weight Dimension et Masses	
	kw	HP	m³/h	0	4.8	6	7.2	8.4	9.6	10.8	12	13.2	mm	kg
			Usqpm	0	21.14	26.42	31.70	36.99	42.27	47.56	52.84	58.12		
	L/min.	0	80	100	120	140	160	180	200	220	MANDATA • DISCHARGE • REFOULEMENT 2" 1/2			
PREVALENZA m • TOTAL HEAD m • HAUTEUR D'ELEVATION m			78	72	70	66	61	56	51	45	37	610	14.1	
S13-5	2.2	3	110	102	98	93	86	79	72	63	53	690	15.2	
S13-7	3	4	125	116	111	105	98	91	82	72	60	725	15.7	
S13-8	3.7	5	141	130	125	119	111	102	92	81	68	765	16.3	
S13-9	4	5.5	204	188	180	173	161	148	134	117	100	920	18.5	
S13-13	5.5	7.5	265	248	238	226	213	195	175	153	127	1065	20.6	
S13-17	7.5	10	328	304	293	278	260	240	216	189	159	1220	22.9	
S13-21	9.3	12.5	390	365	350	333	313	288	258	225	190	1375	25.1	
S13-25	11	15	460	422	405	385	360	330	297	262	220	1575	27.3	

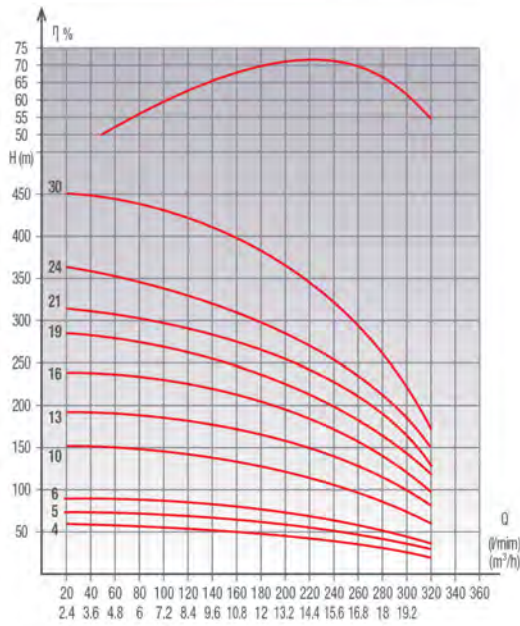

Tipo Type Type	Motore Motor Moteur		Q Portata - Capacity - Debit										Dimensioni e Pesì Dimension and Weight Dimension et Masses	
	kw	HP	m³/h	0	7.2	8.4	9.6	10.6	12	13.2	15	18	mm	kg
			Usqpm	0	31.70	36.99	42.27	47.56	52.84	58.12	66.05	79.26		
	L/min.	0	120	140	160	180	200	220	250	300	MANDATA • DISCHARGE • REFOULEMENT 2" 1/2			
PREVALENZA m • TOTAL HEAD m • HAUTEUR D'ELEVATION m			59	57	55	53	50	49	46	41	29	575	13.5	
S18-4	2.2	3	75	71	70	66	63	61	57	51	36	610	14.1	
S18-5	3	4	90	85	83	79	76	72	69	62	44	650	14.6	
S18-6	4	5.5	150	143	138	133	127	122	115	100	71	805	16.8	
S18-10	5.5	7.5	193	183	178	175	168	160	150	134	96	920	18.5	
S18-13	7.5	10	241	228	222	215	206	196	184	162	117	1030	20.1	
S18-16	9.3	12.5	285	270	262	255	244	233	217	192	140	1145	21.8	
S18-19	11	15	314	300	291	281	269	256	241	218	155	1220	22.9	
S18-21	13	17.5	359	343	333	321	308	292	275	258	177	1335	24.6	
S18-24	15	20	449	429	416	402	385	365	344	311	221	1615	28.9	

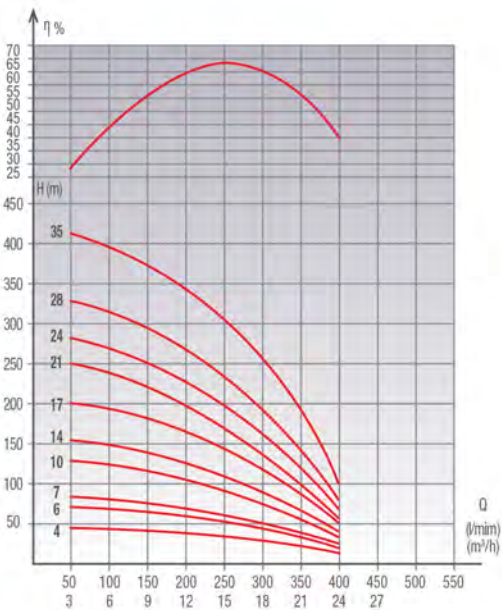

Tipo Type Type	Motore Motor Moteur		Q Portata - Capacity - Debit										Dimensioni e Pesì Dimension and Weight Dimension et Masses	
	kw	HP	m³/h	0	6	12	15	18	21	24	25.5	mm	kg	
			Usqpm	0	26.42	52.84	66.05	79.26	92.47	105.68	112.29			
	L/min.	0	100	200	250	300	350	400	425	MANDATA • DISCHARGE • REFOULEMENT 2" 1/2				
PREVALENZA m • TOTAL HEAD m • HAUTEUR D'ELEVATION m			48	46	40	36	29	22	14	8	620	15.4		
S26-4	2.2	3	72	69	61	54	45	33	20	13	720	16.8		
S26-6	3	4	84	80	71	63	52	39	23	16	770	17.4		
S26-7	4	5.5	120	115	101	90	75	56	33	21	920	19.6		
S26-10	5.5	7.5	168	160	141	124	101	75	45	31	1120	22.6		
S26-14	7.5	10	204	193	169	148	122	89	52	34	1270	24.9		
S26-17	9.3	12.5	252	240	211	186	152	111	67	41	1470	28		
S26-21	11	15	288	271	234	204	167	120	69	44	1620	29.7		
S26-24	13	17.5	336	317	273	238	194	141	80	51	1820	32.6		
S26-28	15	20	420	394	341	296	242	176	100	64	2220	38.6		

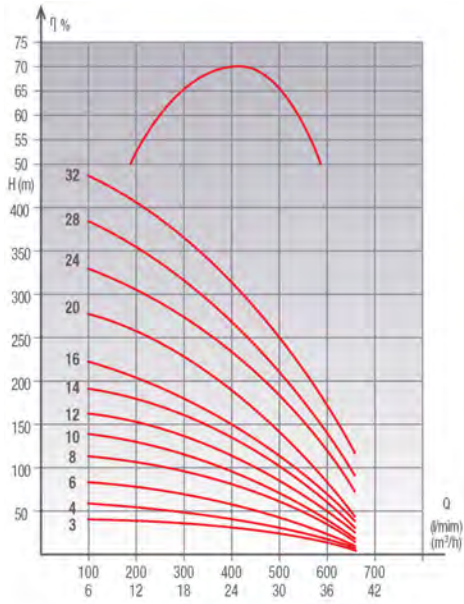

Tipo Type Type	Motore Motor Moteur		Q Portata - Capacity - Debit						Dimensioni e Pes Dimension and Weight Dimension et Masses	
	kw	HP	L/min.						mm	kg
			0	200	300	400	500	600		
S36-3	3	4	44	38	34	28	21	12	590	12.2
S36-4	3.7	5	58	50	46	38	27	16	650	14
S36-6	5.5	7.5	87	76	68	56	42	24	765	15.6
S36-8	7.5	10	117	101	91	75	55	32	880	17.2
S36-10	9.3	12.5	146	127	114	95	70	40	990	18.8
S36-12	11	15	174	152	137	114	84	48	1105	20.4
S36-14	13	17.5	204	178	160	133	98	56	1220	22
S36-16	15	20	233	203	182	151	112	64	1335	23.6
S36-20	18.5	25	292	254	228	190	140	80	1615	27.1
S36-24	22	30	350	305	274	228	168	97	1840	30.7
S36-28	26	35	403	355	316	267	207	130	2070	34.3
S36-32	30	40	465	403	364	312	247	156	2295	38

PRESSIONE - TOTAL HEAD m - HAUTEUR D'ELEVATION m
MANDATA - DISCHARGE - REFOULEMENT 2" 1/2

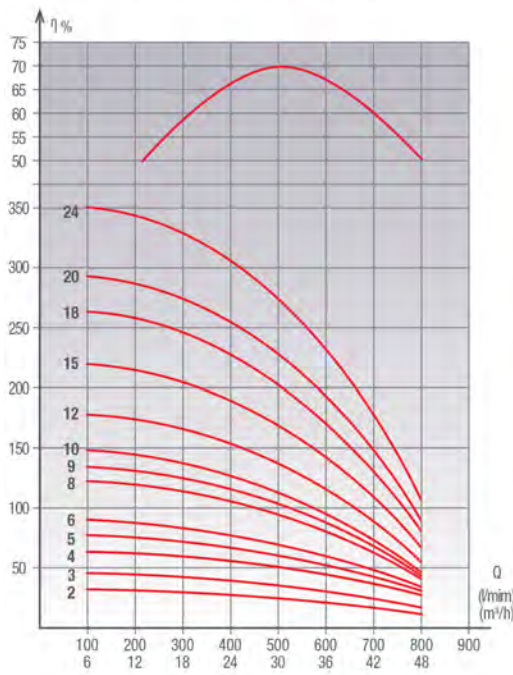

Tipo Type Type	Motore Motor Moteur		Q Portata - Capacity - Debit							Dimensioni e Pes Dimension and Weight Dimension et Masses	
	kw	HP	L/min.							mm	kg
			0	300	400	500	600	700	800		
S48-2	3	4	29	26	25	23	19	14	8	540	12.3
S48-3	4	5.5	46	42	39	36	30	23	13	600	13.3
S48-4	5.5	7.5	60	54	50	46	38	28	18	660	14
S48-5	7.5	10	74	68	63	57	48	36	22	720	15.8
S48-6	9.3	12.5	90	81	76	69	57	43	26	780	16.5
S48-8	11	15	121	109	101	92	76	57	35	900	18
S48-9	13	17.5	135	122	115	103	66	65	40	960	18.8
S48-10	15	20	150	136	127	114	96	72	46	1020	19.5
S48-12	18.5	25	180	163	144	137	115	86	53	1145	21
S48-15	22	30	225	204	191	171	144	108	67	1325	23.3
S48-18	25	35	271	245	229	205	173	129	80	1555	26.4
S48-20	30	40	301	272	254	228	190	142	87	1675	27.9
S48-24	37	50	360	324	303	273	226	163	104	1915	31.5

PRESSIONE - TOTAL HEAD m - HAUTEUR D'ELEVATION m
MANDATA - DISCHARGE - REFOULEMENT 3"

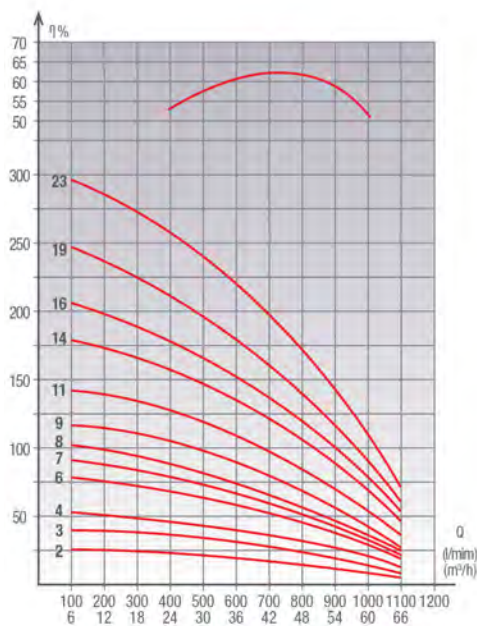

Tipo Type Type	Motore Motor Moteur		Q Portata - Capacity - Debit									Dimensioni e Pes Dimension and Weight Dimension et Masses	
	kw	HP	L/min.									mm	kg
			0	500	600	700	800	900	1000	1100			
S66-2	3.7	5	26	21	18	16	14	12	9	6	540	12.6	
S66-3	5.5	7.5	39	32	28	26	22	17	13	9	600	13.3	
S66-4	7.5	10	52	42	37	33	30	25	19	12	660	14	
S66-6	9.3	12.5	78	62	57	51	44	36	27	18	780	16.5	
S66-7	11	15	92	72	65	58	51	41	32	22	840	17.2	
S66-8	13	17.5	104	83	75	66	57	49	38	25	900	18	
S66-9	15	20	117	94	85	76	66	55	42	30	960	18.8	
S66-11	18.5	25	143	114	102	91	78	66	51	36	1080	20.2	
S66-14	22	30	183	145	131	118	102	85	67	47	1265	22.6	
S66-16	26	35	208	166	151	135	118	97	76	52	1385	24	
S66-19	30	40	246	196	179	160	139	115	88	61	1555	27.2	
S66-23	37	50	298	236	214	191	165	136	103	70	1855	30.8	

PRESSIONE - TOTAL HEAD m - HAUTEUR D'ELEVATION m
MANDATA - DISCHARGE - REFOULEMENT 3"

ORLANDO srl

6'' SUBMERSIBLE PUMPS AP6



Studiata per i pozzi da 6", l'elettropompa sommersa della serie AP6 è di facile manutenzione, solida e robusta. Premente ed aspirante sono ottenute tramite microfusione di acciaio AISI 304. La bocca di mandata è filettata da 3" e la valvola di non ritorno è incorporata. Come standard, fino a 7,5 Hp di potenza la pompa viene fornita predisposta per l'accoppiamento al motore da 4" (NEMA), dal 10Hp per il motore da 6". Per risolvere i problemi dovuti alle grandi pressioni (da 40 bar), la singola pompa diventa un gruppo di pompe in serie (sigla SD).

L'ingombro massimo, con un copricavo, è di 140mm e il senso di rotazione è antiorario, visto dalla bocca di mandata. Per garantirne il funzionamento, il livello dell'acqua deve essere di almeno un metro sopra l'aspirazione. L'impiego può essere continuo. Può essere installata anche in posizione orizzontale.

Gli impieghi sono per acqua pulita e non aggressiva, in particolare: prelievi da pozzi profondi per uso domestico e industriale, impianti idrici di sollevamento o di irrigazione a scorrimento e a pioggia, acquedotti, pressurizzazioni, sistemi antincendio e di lavaggio, alimentazioni di autoclavi e cisterne.



Designed for 6" wells, submersible pump of AP6 series is made of solid and sturdy construction and it's easy to maintain. Bottom and top casing are generated from micro-casting steel AISI 304. Top casing is 3" threaded and the non-return valve is incorporated. As standard, up to 7.5Hp power the pump is supplied for connection to the 4" motor (NEMA), from 10Hp to the motor 6". To solve problems due to great pressures (40 bar), the single pump becomes a group of pumps in series (abbreviation SD).

The maximum overall dimensions, with a cable cover, is 140mm and direction of rotation is counterclockwise viewed from the top casing. To guarantee the functioning, the water level should be at least one meter above the aspiration. The service can be continuous. The pump can also be installed horizontally.

Uses are for clean and non-aggressive water, in particular: domestic and industrial water supply, water systems for lifting or for shower and running irrigation, aqueducts, pressurisations, fire fighting and washing systems, supply of autoclaves and tanks.

Conçue pour puits de 6", la pompe immergée série AP6 est facile à entretenir, robuste et solide. Corps de refoulement et corps d'aspiration sont obtenus par coulée en acier AISI 304. Le corps de refoulement est fileté de 3" et le clapet anti-retour est incorporé. En standard, jusqu'à 7,5 hp de puissance la pompe est livrée pour être raccordée au moteur 4" (NEMA), à partir de 10 hp au moteur 6". Pour résoudre les problèmes dus à la forte pression (40 bar), la pompe unique devient un groupe de pompes en série (abréviation SD).

Les dimensions hors tout maximum, avec une couverture de câble, est de 140mm et le sens de rotation est le sens antihoraire vu de la sortie de la pompe. Pour garantir le fonctionnement, le niveau de l'eau doit être d'au moins un mètre au-dessus de l'aspiration. Le service peut être continu. Il peut aussi installer la pompe en position horizontale.

Les utilisations sont pour l'eau propre et non-agressive, en particulier: alimentation hydrique à emploi civil et industrielle, installations d'élévation ou d'irrigation, aqueducs, pressurisations, installations contre l'incendies et systèmes de lavage, fourniture d'autoclaves et de citernes.

DATI OPERATIVI / OPERATING DATA / DONNEES D'EXPLOITATION

max. portata / capacity / debit:	66	m ³ /h
max. prevalenza / head / hauteur:	840	m
max. potenza / power / puissance:	45	kW
max. contenuto di sabbia / sand content / teneur du sable:	60	g/m ³
max. temperatura acqua / water temperature / température de l'eau:	30	°C
max. numero di avviamenti orari / starting per hour / démarrages par heure:	15	

Possibilità di utilizzo in posizione orizzontale / possibility of use in horizontal position.
Possibilité d'utilisation en position horizontale.

AP6

RICAMBI E MATERIALI - SPARE PARTS AND MATERIALS - PIÈCES DÉTACHÉES ET MATERIAUX

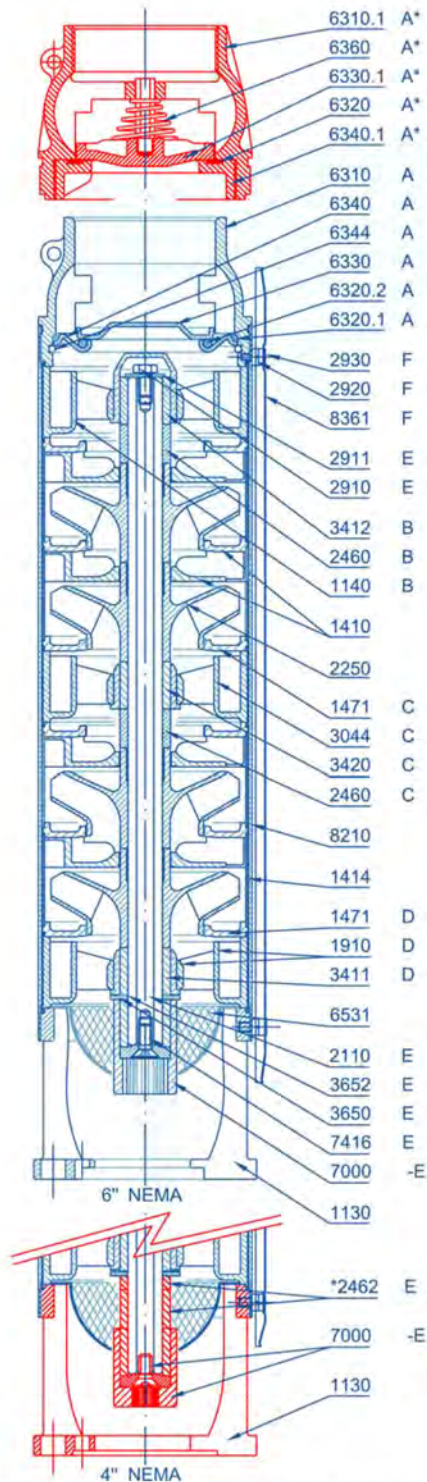

ITEM	DESCRIZIONE PART NAME DENOMINATION	MATERIALE MATERIAL MATERIELE
KIT A		
6310	corpo valvola / top casing / corps du clapet	AISI 304
6320.1	o-ring	NBR
6320.2	o-ring	NBR
6330	otturatore / wing valve / clapet	AISI 304
6340	appoggio otturatore / wing valve support / support de clapet	AISI 304
6344	seeger	AISI 304
KIT A*		
6310.1	corpo valvola / top casing / corps du clapet	AISI 304
6320	guarnizione / gasket / joint	NBR
6330.1	otturatore / wing valve / clapet	AISI 304
6340.1	appoggio otturatore / wing valve support / support de clapet	AISI 304
6360	molla / spring / ressort	AISI 302
KIT B		
1140	supporto superiore / upper support / support superior	PPO+PA
2460	bussola distanziatrice / spacer sleeve / douille entretoise	PPO
3412	bussola supporto / support sleeve / duille de support	AISI 316L
KIT C		
1471	disco / disk / disque	PPO+AISI 304
2460	bussola distanziatrice / spacer sleeve / douille entretoise	PPO
3044	supporto intermedio / intermediate support / support intermédiaire	PPO+ PA
3420	bussola supporto / support sleeve / duille de support	AISI 316L
KIT D		
1471	disco / disk / disque	PPO+AISI 304
1910	supporto inferiore / lower support / support inférieur	PPO+PA
3411	bussola supporto / support sleeve / duille de support	AISI 316L
KIT E		
2110	albero / shaft / arbre	AISI 420
* 2462	2x bussola distanziatrice / spacer sleeve / douille entretoise	PPO
2910	vite / screw / vis	AISI 304
2911	rondella / washer / rondelle	AISI 304
3650	rondella spallamento / up thrust washer / rondelle de butée	AISI 304
3652	distanziale / spacer / entretoise	PA
7000	giunto / coupling / accouplement	AISI 420
7416	vite giunto / coupling screw / vis d'accouplement	AISI 304
KIT F		
2920	4x vite / screw / vis	AISI 304
2930	2x graffetta / clip / clip	AISI 304
8361	copricavo / cable cover / couvre-câble	AISI 304
1130	aspirante	AISI 304
1410	diffusore + disco	PPO+AISI 304
1414	tubo distanziale	AISI 304
2250	girante	PPO
6531	griglia	AISI 304
7000	giunto	AISI 420
8210	tubo esterno	AISI 304

Per ordinare pezzi di ricambio contattare il rivenditore o la sede centrale indicando il modello, il numero seriale e la data di assemblaggio della pompa, i kit e/o i codici dei componenti desiderati.

To order spare parts, keep in touch with the dealer or our offices communicating pump model, serial number and assembling date, kits and/or codes of required parts.

Pour commander des pièces détachées, nous vous prions de contacter le revendeur ou le bureau principal en indiquant le modèle, le numéro de série et la date de l'assemblage de la pompe, les kits et/ou les codes des pièces nécessaires.

AP6 B

tolleranze secondo / tolerances according to / tolérance conformes aux ISO 9906 ann.A gr.2 2850 rpm

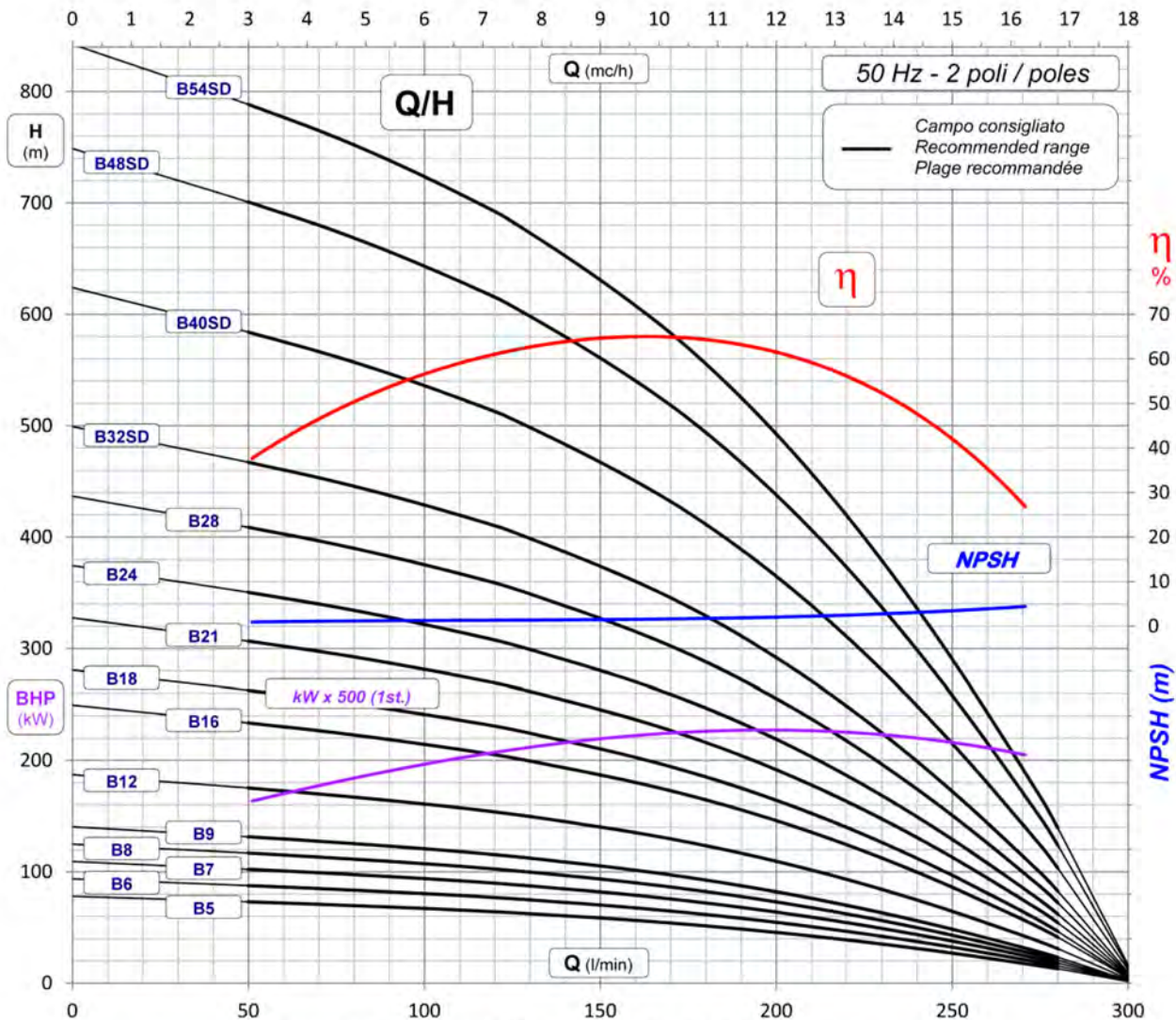

DATI OPERATIVI / OPERATING DATA / DONNEES D'EXPLOITATION

TIPO / TYPE	ST	L (mm)	Kg	N	M	P2		con / with / avec		FMO4 T / FME6	
						HP	Kw	L1(mm)	Kg	A (400V)	P1(Kw)
AP6 B5	5	478	9,8	1.410	4"	3	2,2	898	12	6,2	3,0
AP6 B6	6	516	10,4	1.690	4"	4	3	936	13	7,8	3,8
AP6 B7	7	554	11,1	1.970	4"	4	3	974	13	7,8	3,8
AP6 B8	8	592	11,8	2.250	4"	5	3,7	1.060	15	9,8	4,7
AP6 B9	9	630	12,4	2.530	4"	5	3,7	1.098	15	9,8	4,7
AP6 B12	12	744	14,4	3.370	4"	7,5	5,5	1.282	19	13,8	7,1
AP6 B16	16	895	16,9	4.500	6"	10	7,5	1.579	24	18	9,7
AP6 B18	18	972	18,3	5.060	6"	12,5	9,2	1.696	80	22	11,6
AP6 B21	21	1.086	22,2	5.900	6"	12,5	9,2	1.810	84	22	11,6
AP6 B24	24	1.200	24,2	6.740	6"	15	11	1.969	91	26	13,6
AP6 B28	28	1.404	27,7	7.870	6"	17,5	13	2.218	100	30	15,9
AP6 B32SD	32	1.693	41,0	8.990	6"	20	15	2.552	117	34	18,5
AP6 B40SD	40	1.997	47,5	11.240	6"	25	18,5	2.946	135	41	22,3
AP6 B48SD	48	2.301	54,1	13.480	6"	30	22	3.335	150	49	26,5
AP6 B54SD	54	2.529	59,0	15.170	6"	35	26	3.658	165	57	31,0

ST = stadi / stages / étages
 N = spinta idraulica / hydraulic thrust / poussée hydraulique
 M = accoppiamento consigliato / recommended coupling / couplage recommandé NEMA
 P2 = potenza nominale motore / motor nominal power / puissance nominale moteur
 P1 = potenza totale assorbita / total power consumption / consommation totale

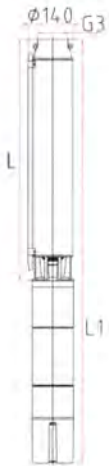

AP6 D

tolleranze secondo / tolerances according to / tolérance conformes aux ISO 9906 ann.A gr.2

2850 rpm

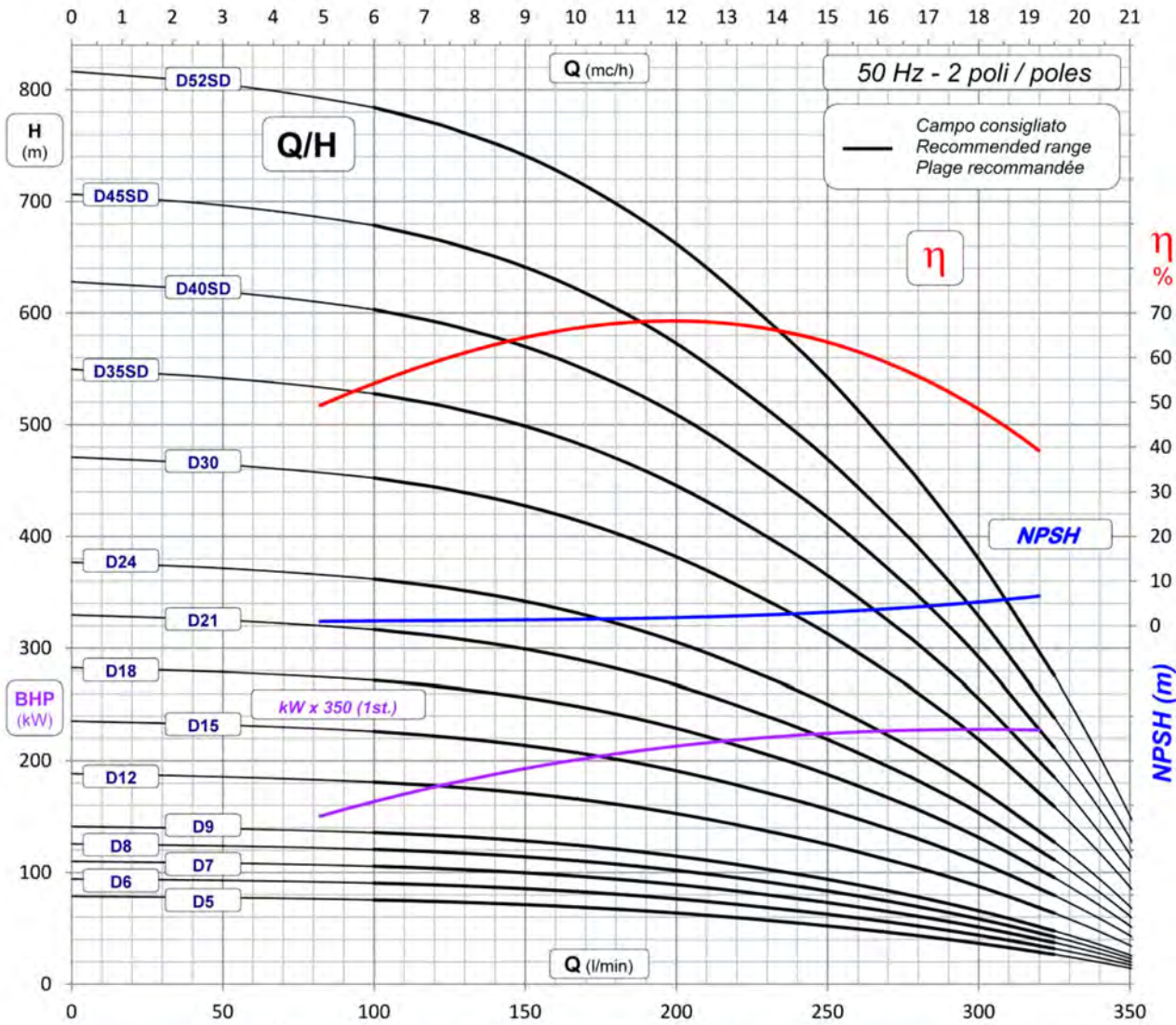

DATI OPERATIVI / OPERATING DATA / DONNEES D'EXPLOITATION											
TIPO / TYPE	ST	L (mm)	Kg	N	M	P2		con / with / avec		FMO4 T / FME6	
						HP	Kw	L1(mm)	Kg	A (400V)	P1(Kw)
AP6 D5	5	478	9,8	1.420	4"	4	3	898	23	7,8	3,8
AP6 D6	6	516	10,5	1.700	4"	5,5	4	984	26	9,8	5,1
AP6 D7	7	554	11,1	1.980	4"	7,5	5,5	1.092	30	13,8	7,1
AP6 D8	8	592	11,8	2.270	4"	7,5	5,5	1.130	31	13,8	7,1
AP6 D9	9	630	12,4	2.550	4"	7,5	5,5	1.168	31	13,8	7,1
AP6 D12	12	744	14,3	3.400	6"	10	7,5	1.428	72	18	9,7
AP6 D15	15	858	16,3	4.240	6"	12,5	9,2	1.582	79	22	11,6
AP6 D18	18	972	18,2	5.090	6"	15	11	1.741	86	26	13,6
AP6 D21	21	1.086	22,2	5.940	6"	17,5	13	1.900	95	30	15,9
AP6 D24	24	1.200	24,1	6.790	6"	20	15	2.059	100	34	18,5
AP6 D30	30	1.480	28,9	8.480	6"	25	18,5	2.429	116	41	22,3
AP6 D35SD	35	1.807	43,1	9.900	6"	30	22	2.841	139	49	26,5
AP6 D40SD	40	1.997	47,2	11.310	6"	35	26	3.126	153	57	31,0
AP6 D45SD	45	2.187	51,3	12.720	6"	40	30	3.356	161	67	36,6
AP6 D52SD	52	2.453	57,0	14.700	6"	50	37	3.654	173	74	44,0



ST = stadi / stages / étages
 N = spinta idraulica / hydraulic thrust / poussée hydraulique
 M = accoppiamento consigliato / recommended coupling / couplage recommandé NEMA
 P2 = potenza nominale motore / motor nominal power / puissance nominale moteur
 P1 = potenza totale assorbita / total power consumption / consommation totale

AP6 E

tolleranze secondo / tolerances according to / tolérance conformes aux ISO 9906 ann.A gr.2 2850 rpm

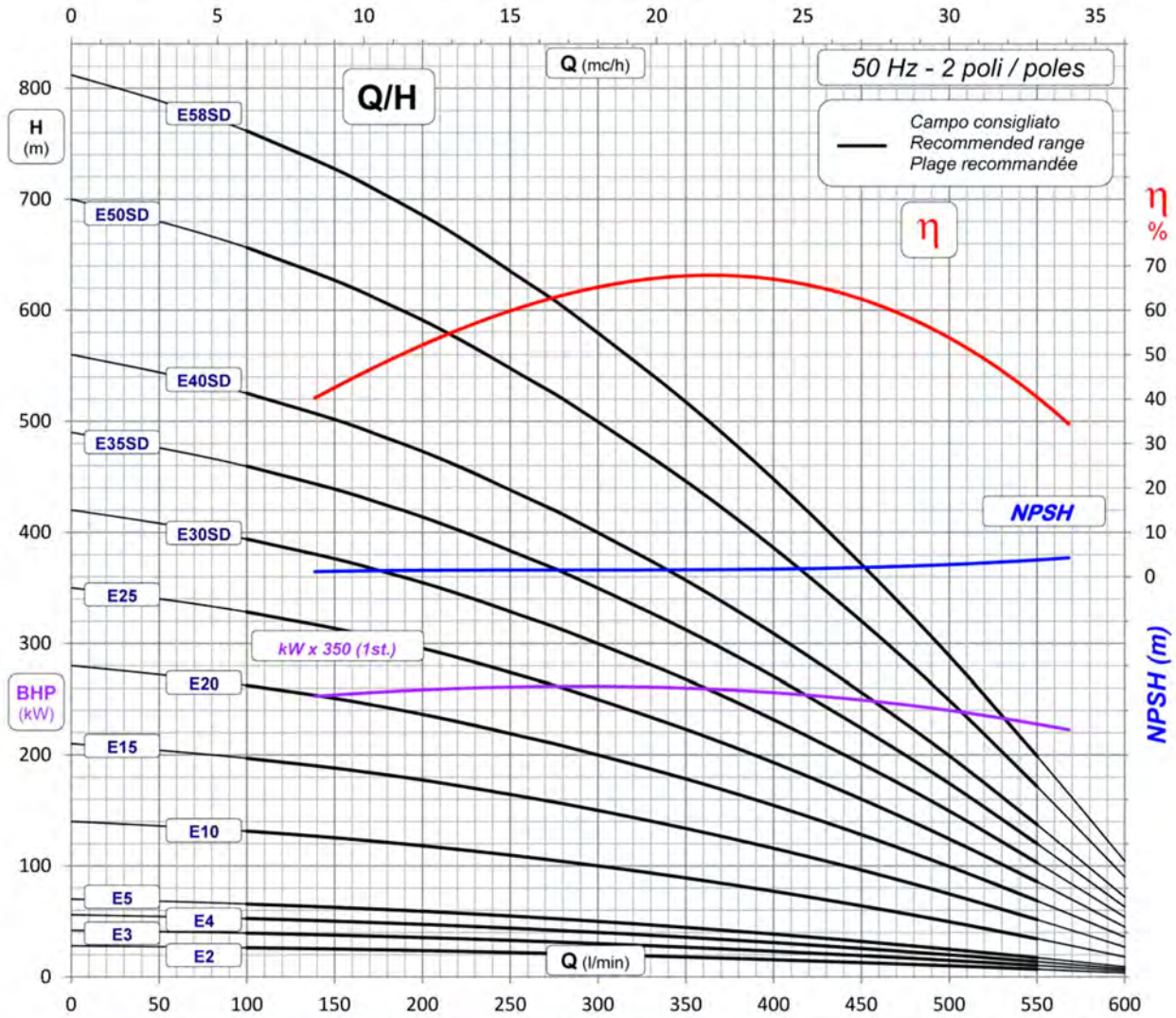

DATI OPERATIVI / OPERATING DATA / DONNEES D'EXPLOITATION											
TIPO / TYPE	ST	L (mm)	Kg	N	M	P2		con / with / avec		FMO4 T / FME6	
						HP	Kw	L1(mm)	Kg	A (400V)	P1(Kw)
AP6 E2	2	402	8,7	790	4"	2	1,5	787	19	4,6	2,2
AP6 E3	3	459	9,7	1.180	4"	3	2,2	879	22	6,2	3,0
AP6 E4	4	516	10,8	1.570	4"	4	3	934	24	7,8	3,8
AP6 E5	5	573	11,1	1.960	4"	5	3,7	1.041	26	9,8	4,7
AP6 E10	10	858	17,0	3.920	6"	10	7,5	1.542	74	18	9,7
AP6 E15	15	1.143	22,5	5.880	6"	15	11	1.912	90	26	13,6
AP6 E20	20	1.480	23,4	7.840	6"	20	15	2.339	99	34	18,5
AP6 E25	25	1.764	32,6	9.800	6"	25	18,5	2.713	120	41	22,3
AP6 E30SD	30	2.187	49,1	11.760	6"	30	22	3.221	145	49	26,5
AP6 E35SD	35	2.472	54,7	13.720	6"	35	26	3.601	161	57	31,0
AP6 E40SD	40	2.861	62,5	15.680	6"	40	30	4.030	173	67	36,6
AP6 E50SD	50	3.431	73,7	19.600	6"	50	37	4.632	190	74	44,0
AP6 E58SD	58	3.773	80,4	22.740	6"	60	45	5.048	196	95	54,9



ST = stadi / stages / étages
 N = spinta idraulica / hydraulic thrust / poussée hydraulique
 M = accoppiamento consigliato / recommended coupling / couplage recommandé NEMA
 P2= potenza nominale motore / motor nominal power / puissance nominale moteur
 P1= potenza totale assorbita / total power consumption / consommation totale

AP6 F

tolleranze secondo / tolerances according to / tolérance conformes aux ISO 9906 ann.A gr.2

2850 rpm

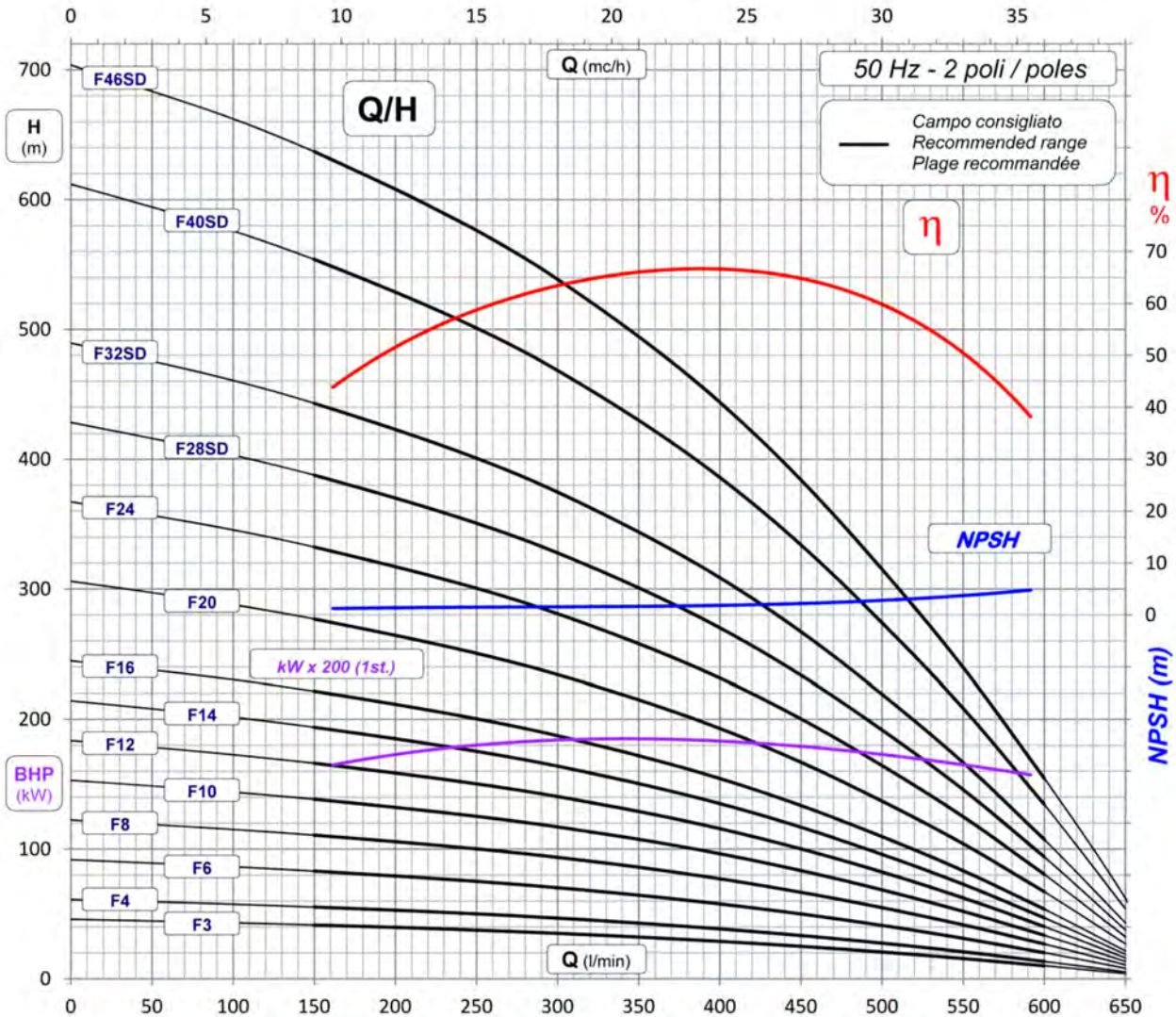

DATI OPERATIVI / OPERATING DATA / DONNEES D'EXPLOITATION											
TIPO / TYPE	ST	L (mm)	Kg	N	M	P2				FMO4 T / FME6	
						HP	Kw	L1(mm)	Kg	A (400V)	P1(Kw)
AP6 F3	3	459	9,8	1.290	4"	4	3	879	23	7,8	3,8
AP6 F4	4	516	10,8	1.720	4"	5,5	4	984	26	9,8	5,1
AP6 F6	6	630	12,9	2.570	4"	7,5	5,5	1.168	32	13,8	7,1
AP6 F8	8	744	14,9	3.430	6"	10	7,5	1.428	72	18	9,7
AP6 F10	10	858	17,1	4.290	6"	12,5	9,2	1.582	79	22	11,6
AP6 F12	12	972	19,2	5.150	6"	15	11	1.741	86	26	13,6
AP6 F14	14	1.086	21,4	6.000	6"	17,5	13	1.900	93	30	15,9
AP6 F16	16	1.200	23,4	6.860	6"	20	15	2.059	99	34	18,5
AP6 F20	20	1.480	27,7	8.570	6"	25	18,5	2.429	115	41	22,3
AP6 F24	24	1.707	31,5	10.290	6"	30	22	2.741	128	49	26,5
AP6 F28SD	28	2.073	46,9	12.000	6"	35	26	3.202	153	57	31,0
AP6 F32SD	32	2.301	51,2	13.710	6"	40	30	3.470	161	67	36,6
AP6 F40SD	40	2.757	59,8	17.140	6"	50	37	3.958	176	74	44,0
AP6 F46SD	46	3.099	66,3	19.710	6"	60	45	4.374	182	95	54,9

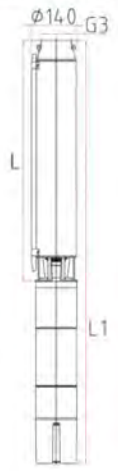

ST = stadi / stages / étages
 N = spinta idraulica / hydraulic thrust / poussée hydraulique
 M = accoppiamento consigliato / recommended coupling / couplage recommandé NEMA
 P2= potenza nominale motore / motor nominal power / puissance nominale moteur
 P1= potenza totale assorbita / total power consumption / consommation totale

AP6 H

tolleranze secondo / tolerances according to / tolérance conformes aux ISO 9906 ann.A gr.2

2850 rpm

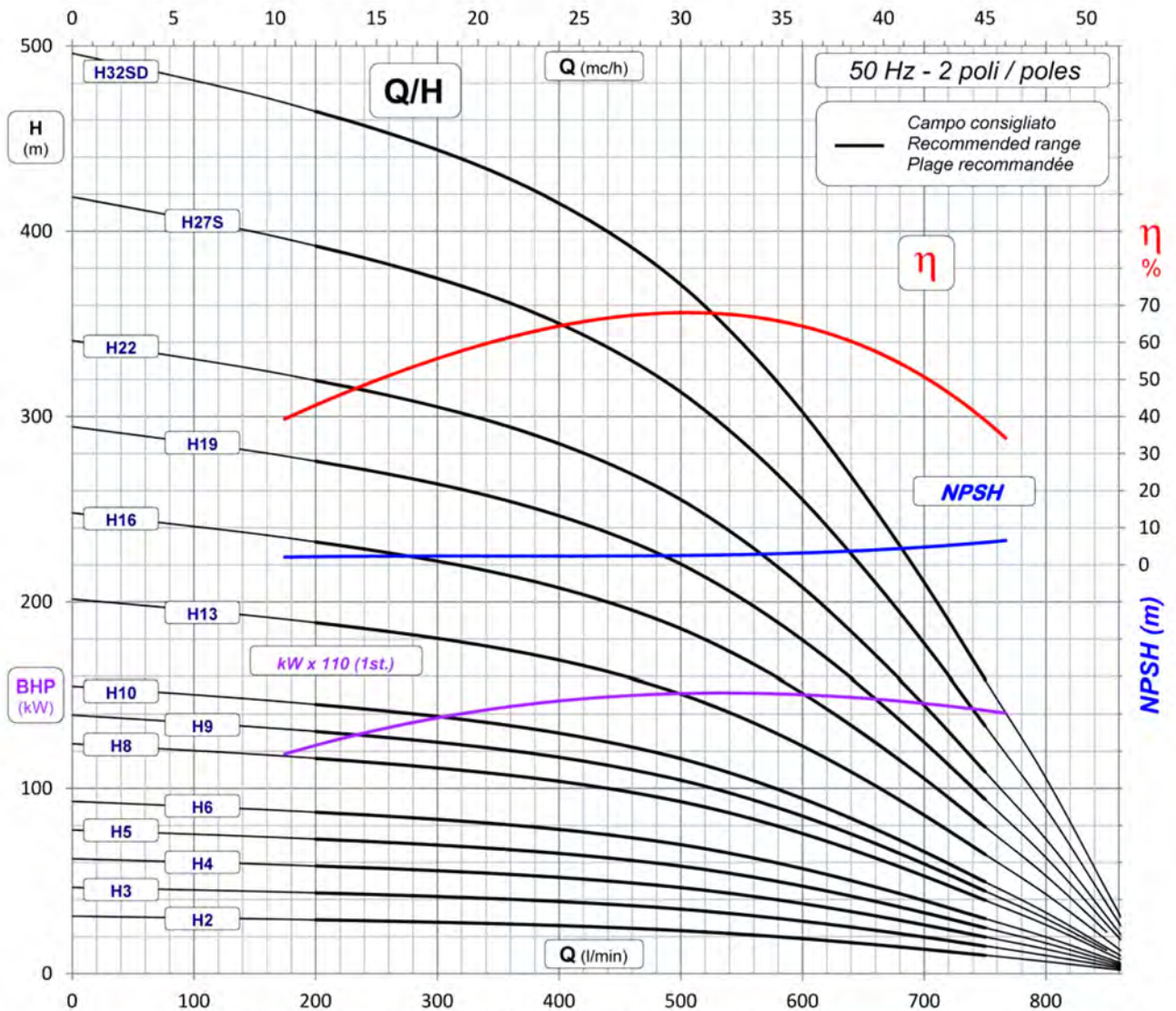

TIPO / TYPE	ST	L (mm)	Kg	N	M	P2		con / with / avec		FMO4 T / FME6	
						HP	Kw	L1(mm)	Kg	A (400V)	P1(Kw)
AP6 H2	2	408	8,5	870	4"	4	3	828	21	7,8	3,8
AP6 H3	3	468	9,4	1.310	4"	5,5	4	936	25	9,8	5,1
AP6 H4	4	528	10,3	1.740	4"	7,5	5,5	1.066	29	13,8	7,1
AP6 H5	5	588	11,2	2.170	6"	10	7,5	1.272	68	18	9,7
AP6 H6	6	648	12,1	2.610	6"	12,5	9,2	1.372	74	22	11,6
AP6 H8	8	768	13,9	3.480	6"	15	11	1.537	81	26	13,6
AP6 H9	9	828	15,0	3.910	6"	17,5	13	1.642	87	30	15,9
AP6 H10	10	888	15,9	4.340	6"	20	15	1.747	92	34	18,5
AP6 H13	13	1.068	18,6	5.650	6"	25	18,5	2.017	106	41	22,3
AP6 H16	16	1.248	21,5	6.950	6"	30	22	2.282	118	49	26,5
AP6 H19	19	1.480	27,6	8.250	6"	35	26	2.609	134	57	31,0
AP6 H22	22	1.660	30,6	9.550	6"	40	30	2.829	141	67	36,6
AP6 H27S	27	1.959	41,2	11.720	6"	50	37	3.160	157	74	44,0
AP6 H32SD	32	2.397	53,1	13.890	6"	60	45	3.672	169	95	54,9

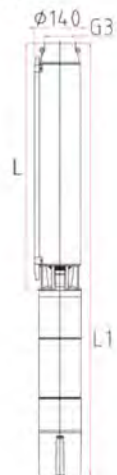

ST = stadi / stages / étages
 N = spinta idraulica / hydraulic thrust / poussée hydraulique
 M = accoppiamento consigliato / recommended coupling / couplage recommandé NEMA
 P2= potenza nominale motore / motor nominal power / puissance nominale moteur
 P1= potenza totale assorbita / total power consumption / consommation totale

AP6 I

tolleranze secondo / tolerances according to / tolérance conformes aux ISO 9906 ann.A gr.2 2850 rpm

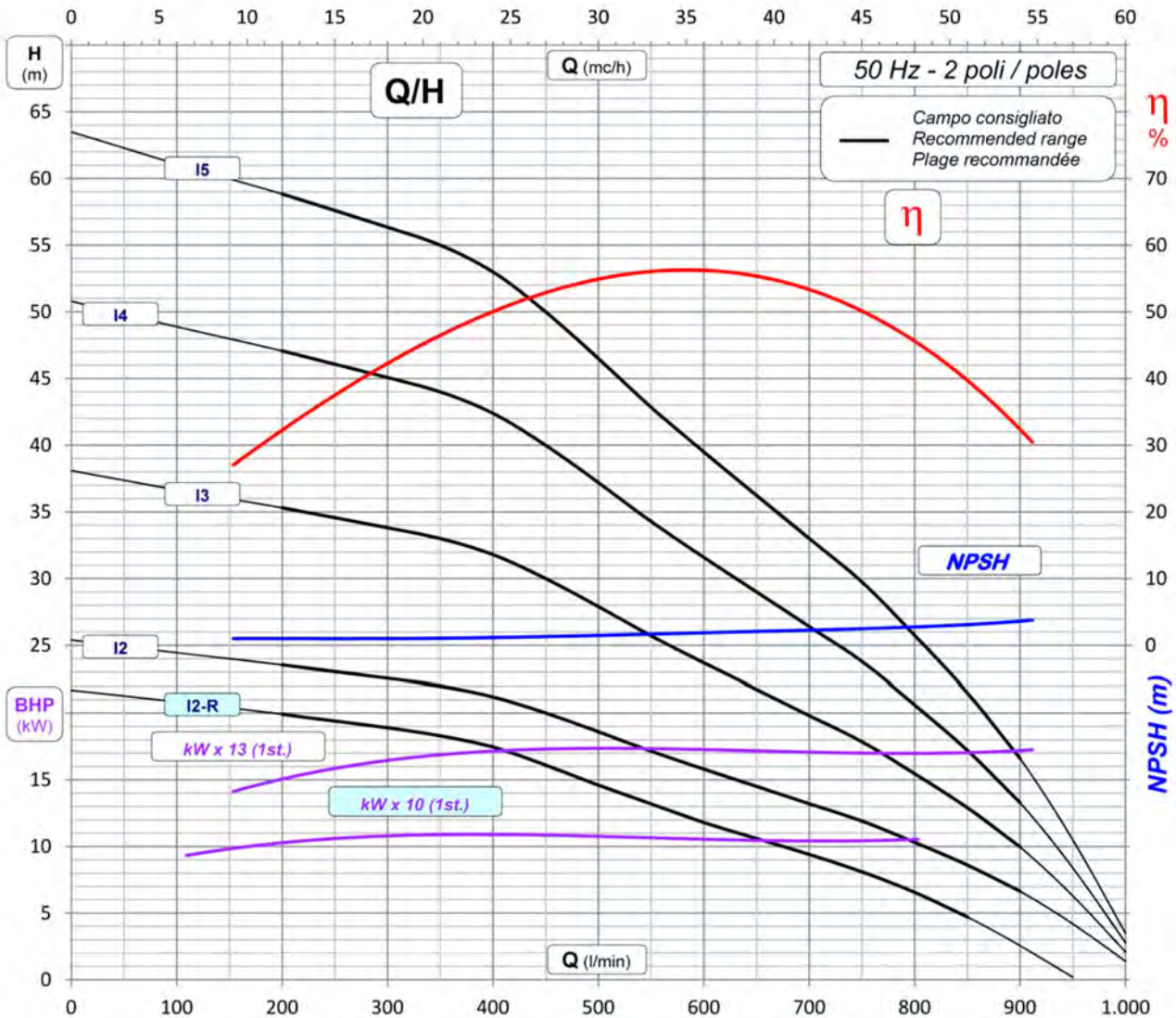

DATI OPERATIVI / OPERATING DATA / DONNEES D'EXPLOITATION

TIPO / TYPE	ST	L (mm)	Kg	N	M	P2 con / with / avec			FMO4 T / FME6		
						HP	Kw	L1(mm)	Kg	A (400V)	P1(Kw)
AP6 I2-R	2	408	8,5	740	4"	3	2,2	828	21	6,2	3,0
AP6 I2	2	408	8,5	870	4"	4	3	828	21	7,8	3,8
AP6 I3	3	468	9,4	1.300	4"	5,5	4	936	25	9,8	5,1
AP6 I4	4	528	10,2	1.730	4"	7,5	5,5	1.066	29	13,8	7,1
AP6 I5	5	588	11,2	2.160	6"	10	7,5	1.272	68	18	9,7



ST = stadi / stages / étages
 N = spinta idraulica / hydraulic thrust / poussée hydraulique
 M = accoppiamento consigliato / recommended coupling / couplage recommandé NEMA
 P2 = potenza nominale motore / motor nominal power / puissance nominale moteur
 P1 = potenza totale assorbita / total power consumption / consommation totale

AP6 L

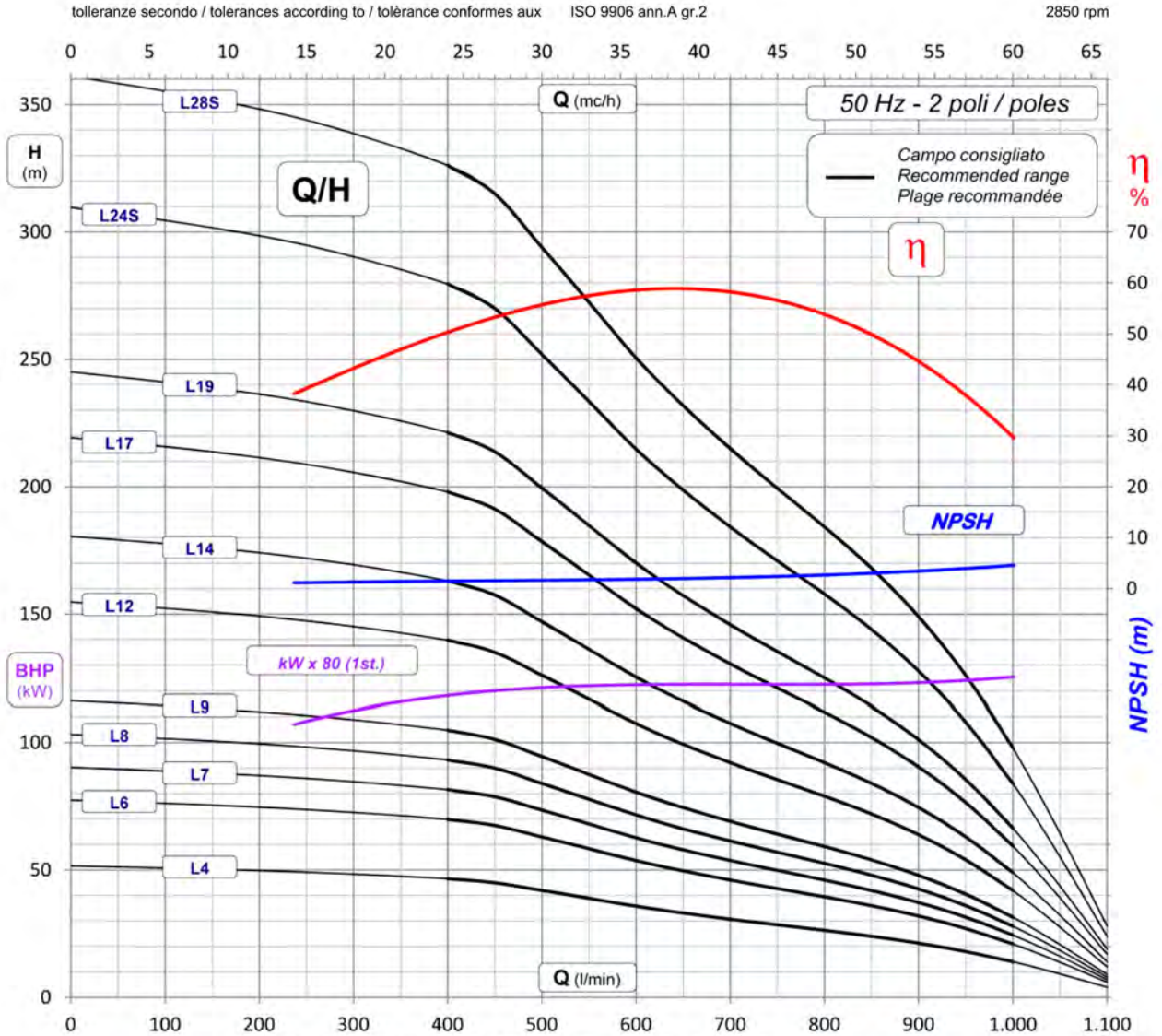

DATI OPERATIVI / OPERATING DATA / DONNEES D'EXPLOITATION

TIPO / TYPE	ST	L (mm)	Kg	N	M	P2		con / with / avec		FMO4 T / FME6	
						HP	Kw	L1(mm)	Kg	A (400V)	P1(Kw)
AP6 L4	4	528	10,2	1.760	6"	10	7,5	1.212	67	18	9,7
AP6 L6	6	648	12,0	2.640	6"	12,5	9,2	1.372	74	22	11,6
AP6 L7	7	708	12,9	3.070	6"	15	11	1.477	80	26	13,6
AP6 L8	8	768	13,8	3.510	6"	17,5	13	1.582	86	30	15,9
AP6 L9	9	828	14,8	3.950	6"	20	15	1.687	91	34	18,5
AP6 L12	12	1.008	15,7	5.270	6"	25	18,5	1.957	103	41	22,3
AP6 L14	14	1.128	17,8	6.140	6"	30	22	2.162	114	49	26,5
AP6 L17	17	1.308	21,9	7.460	6"	35	26	2.437	128	57	31,0
AP6 L19	19	1.480	26,8	8.340	6"	40	30	2.649	137	67	36,6
AP6 L24S	24	1.779	37,1	10.530	6"	50	37	2.980	153	74	44,0
AP6 L28S	28	1.959	41,7	12.290	6"	60	45	3.234	158	95	54,9



ST = stadi / stages / étages
 N = spinta idraulica / hydraulic thrust / poussée hydraulique
 M = accoppiamento consigliato / recommended coupling / couplage recommandé NEMA
 P2= potenza nominale motore / motor nominal power / puissance nominale moteur
 P1= potenza totale assorbita / total power consumption / consommation totale

ORLANDO srl



Art.: P DB CS4...

ORLANDO *orl*

Multistage, centrifugal, submerged motor-driven pumps for 4" wells or larger, able to generate a vast range of heads and flow rates.

They can be employed in a wide range of lifting, distributing and pressurising applications in civil and industrial water installations, supplying autoclaves and cisterns, fire fighting and washing systems, irrigation systems.

Constructional characteristics:

Base support (with built-in filter) and upper head (with built-in check valve) in technopolymer.

Plastic cable cover.

Two-pole, water-filled, submersible TESLA electric motor, built entirely in AISI 304 stainless steel for the parts in contact with the water. Canned-type stator.

Capacitor and manually resettable overload protection inside the panel.

Protection for the three-phase version is the responsibility of the user.

Complete with Control Box, 15 or 30 m of electric wire (depending on the models) and safety cord.

Pumped liquid: clean, free from solid or abrasive substances, chemically neutral and close to the characteristics of water.

Liquid temp. range: from 0°C to +40°C.

Motor protection level: IP 68.

Insulation class: F.

Special versions on request: with different voltages and/or frequencies.

Maximum content of sand: 120 g/m³.

The CONTROL BOX HS is available on request for the single phase version to increase the static torque.

Available also with TESLA oil - filled motor. (On request).

MODEL	CODE	ELECTRICAL DATA			DNM	H mm	CABLE LENGHT mt.	WEIGHT KG	Q.TY x PALLET	
		VOLTAGE 50 Hz	P2 NOMINAL							
			KW	HP						
CS4A-8 M	104100202	1x230 V ~	0,37	0,5	3,3	1 1/2" G-F	577	15	13	18
CS4A-12 M	104100212	1x230 V ~	0,37	0,5	3,3	1 1/2" G-F	677	15	14,7	18
CS4A-12 T	104103012	3x400 V ~	0,37	0,5	1,6	1 1/2" G-F	657	15	12,9	18
CS4A-18 M	104100222	1x230 V ~	0,55	0,75	4,6	1 1/2" G-F	825	30	18,3	18
CS4A-18 T	104103022	3x400 V ~	0,55	0,75	8	1 1/2" G-F	795	30	17,2	18
CS4A-25 M	104100232	1x230 V ~	0,75	1	6,2	1 1/2" G-F	993	30	22	18
CS4A-25 T	104103032	3x400 V ~	0,75	1	12	1 1/2" G-F	965	30	19,4	18
CS4A-36 M	104100242	1x230 V ~	1,1	1,5	8,6	1 1/2" G-F	1303	30	25	18
CS4A-36 T	104103042	3x400 V ~	1,1	1,5	14	1 1/2" G-F	1245	30	22,6	18
CS4B-5 M	104100402	1x230 V ~	0,25	0,33	3,3	1 1/2" G-F	530	15	12,5	18
CS4B-8 M	104100412	1x230 V ~	0,37	0,5	3,3	1 1/2" G-F	617	15	14	18
CS4B-8 T	104103212	3x400 V ~	0,37	0,5	1,6	1 1/2" G-F	597	15	12,2	18
CS4B-12 M	104100422	1x230 V ~	0,55	0,75	4,6	1 1/2" G-F	735	15	15,9	18
CS4B-12 T	104103222	3x400 V ~	0,55	0,75	8	1 1/2" G-F	707	15	13,5	18
CS4B-16 M	104100432	1x230 V ~	0,75	1	6,2	1 1/2" G-F	853	30	20	18
CS4B-16 T	104103232	3x400 V ~	0,75	1	12	1 1/2" G-F	825	30	18,4	18
CS4B-24 M	104100442	1x230 V ~	1,1	1,5	8,6	1 1/2" G-F	1090	30	25	18
CS4B-24 T	104103242	3x400 V ~	1,1	1,5	14	1 1/2" G-F	1033	30	21	18
CS4C-6 M	104100602	1x230 V ~	0,37	0,5	3,3	1 1/2" G-F	632	15	14,1	18
CS4C-6 T	104103402	3x400 V ~	0,37	0,5	1,6	1 1/2" G-F	612	15	12	18
CS4C-9 M	104100612	1x230 V ~	0,55	0,75	4,6	1 1/2" G-F	758	15	14,8	18
CS4C-9 T	104103412	3x400 V ~	0,55	0,75	8	1 1/2" G-F	729	15	13	18
CS4C-13 M	104100622	1x230 V ~	0,75	1	6,2	1 1/2" G-F	915	30	21,2	18
CS4C-13 T	104103422	3x400 V ~	0,75	1	12	1 1/2" G-F	884	30	18,5	18
CS4C-19 M	104100632	1x230 V ~	1,1	1,5	8,6	1 1/2" G-F	1168	30	23,7	18
CS4C-19 T	104103432	3x400 V ~	1,1	1,5	5,7	1 1/2" G-F	1110	30	21,3	18
CS4D-4 M	104100802	1x230 V ~	0,37	0,5	3,3	1 1/2" G-F	567	15	14	18
CS4D-4 T	104103602	3x400 V ~	0,37	0,5	1,6	1 1/2" G-F	547	15	11,8	18
CS4D-6 M	104100812	1x230 V ~	0,55	0,75	4,6	1 1/2" G-F	660	15	14,2	18
CS4D-6 T	104103612	3x400 V ~	0,55	0,75	8	1 1/2" G-F	632	15	13,1	18
CS4D-8 M	104100822	1x230 V ~	0,75	1	6,2	1 1/2" G-F	753	15	17,2	18
CS4D-8 T	104103622	3x400 V ~	0,75	1	12	1 1/2" G-F	725	15	14,6	18
CS4D-13 M	104100832	1x230 V ~	1,1	1,5	8,6	1 1/2" G-F	973	30	22,6	18
CS4D-13 T	104103632	3x400 V ~	1,1	1,5	5,7	1 1/2" G-F	915	30	20,2	18

AVAILABLE THREE-PHASE 3 X 230V VERSION

ORLANDO srl

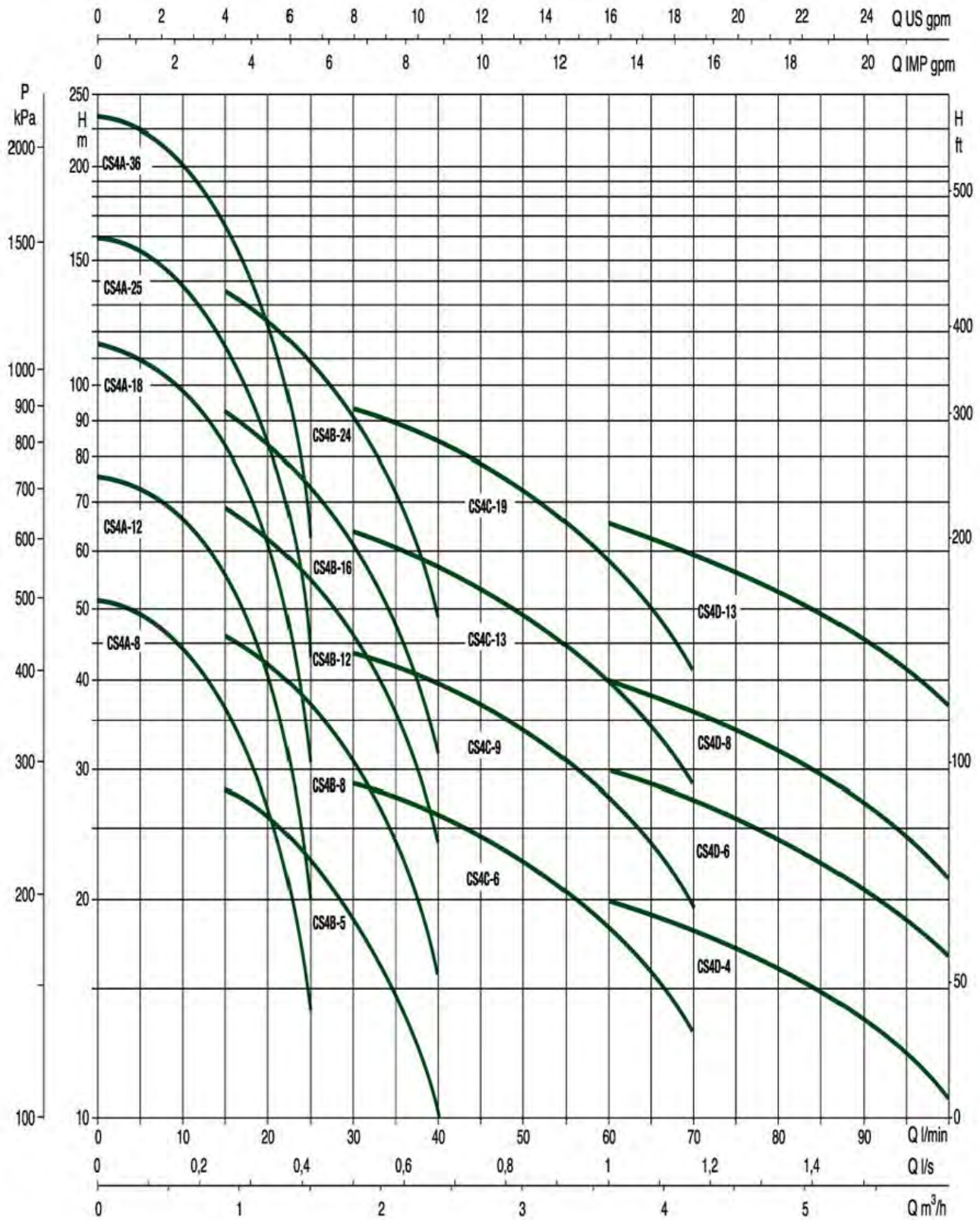

ORLANDO srl

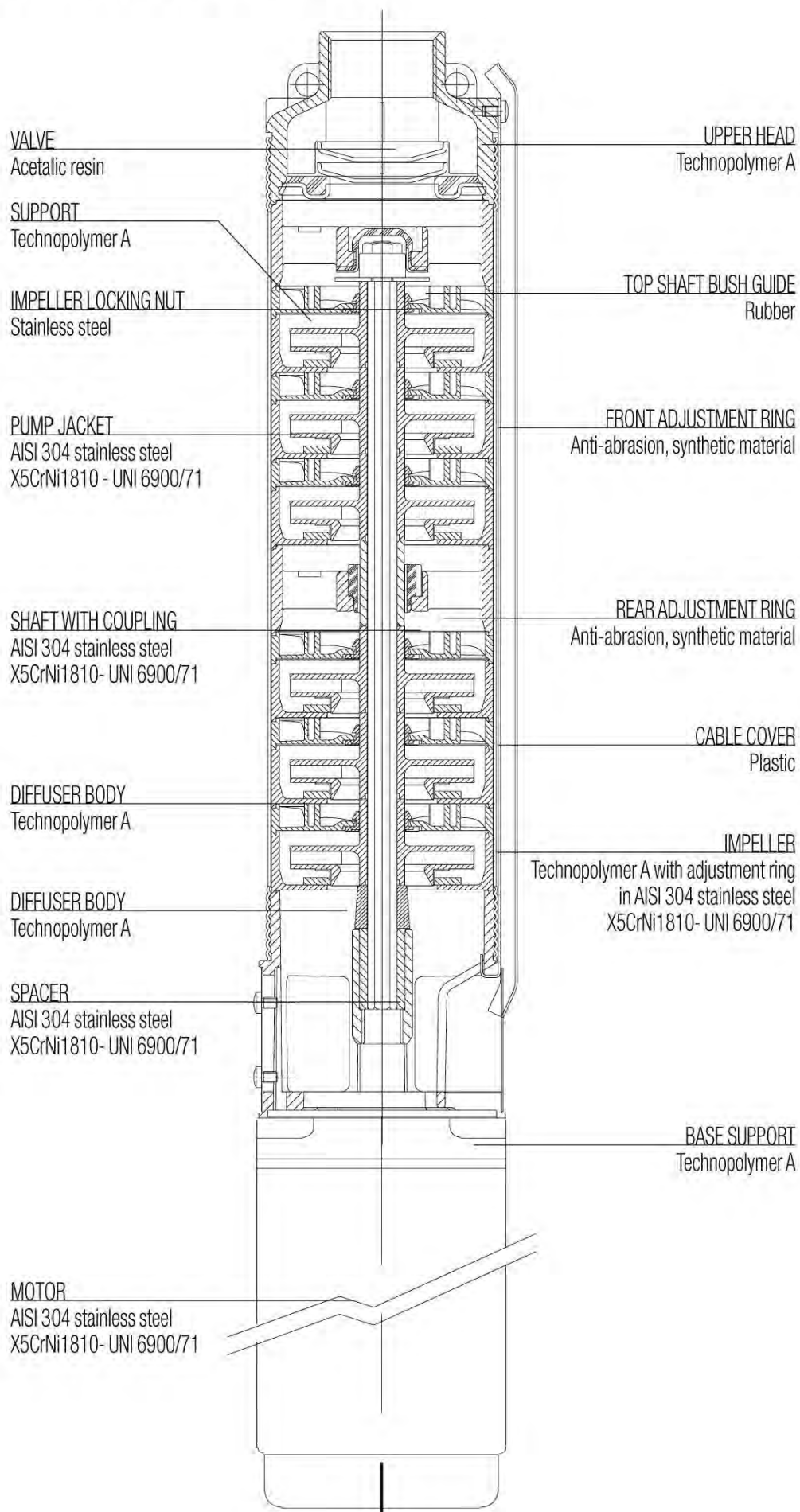

ORLANDO srl

GS 4" Series

Multi-stage centrifugal submersible pumps for clean water in 4" wells. High content of AISI 304 stainless steel. The floating impeller design ensures an excellent resistance to wear.

The upper and lower supports are made of precision-cast stainless steel ensuring resistance to corrosion, strength and rigid coupling to the motor.

The non-return valve is integrated in the head to support the weight of the column of water and protect against water hammer, thus safeguarding impellers and diffusers. Can also operate in a horizontal position.

Specifications

Delivery: up to 21 m³/h

Head: up to 340 metres

Power supply: three-phase and single-phase 50 and 60 Hz

Single-phase version: 220-240 V, 50Hz

Three-phase version: 380-415 V;

overload protection to be provided by user and installed in the control box (see control box section)

Power: 0.25 kW to 7.5 kW

Maximum overall diameter of pump (cable cover included): 99 mm

Water temperature: 0°C to +35°C

Maximum permissible quantity of suspended sand: 150 g/m³

Materials

Valve cap, valve seat: Stainless steel

Valve gasket: NBR

Valve stop ring: Stainless steel

Upper support: Technopolymer

Bush bearings: Polyurethane

Impeller, diffuser: Technopolymer

Diffuser case, shim, pump shaft, outer sleeve, spacer, filter, coupling, cable cover: Stainless Steel

Applications

Water supply

Pressure boosting

Irrigation

Rain water collection

Fire-fighting



2GS SERIES

Hydraulic performance table at 50 Hz

PUMP TYPE	N. OF STAGES	MOTOR POWER		Q = DELIVERY					
		kW	HP	H = TOTAL HEAD METRES COLUMN OF WATER					
				l/min	0	20	25	30	40
				0	1,2	1,5	1,8	2,4	3
				m ³ /h					
2GS02 ⁽¹⁾	5	0,37	0,5	33	30	28	26	20	13
2GS03	7	0,37	0,5	47	42	40	36	29	19
2GS05	10	0,55	0,75	67	60	56	52	41	27
2GS07	14	0,75	1	93	83	79	73	57	37
2GS11	20	1,1	1,5	133	119	113	104	82	53
2GS15	28	1,5	2	187	167	158	146	115	74
2GS22	40	2,2	3	267	238	226	208	164	106
2GS30	52	3	4	347	309	294	271	213	138

(1) Maximum pump absorbed power: 0,25 kW - 0,33 HP.

2gs-2p50-en_c_th

2GS..4OS SERIES

Dimensions and weights

ELECTRIC PUMP TYPE *	NUMBER OF STAGES	DNM	DIMENSIONS (mm)		PUMP WEIGHT kg	ELECTRIC PUMP WEIGHT kg
			L1	L		
2GS02M-4OS	5	Rp 1 1/4	245	598	2,6	10,2
2GS03M-4OS	7	Rp 1 1/4	280	633	2,9	10,5
2GS05M-4OS	10	Rp 1 1/4	332	685	3,5	11,7
2GS07M-4OS	14	Rp 1 1/4	402	780	4,2	13,5
2GS11M-4OS	20	Rp 1 1/4	507	920	5,3	16,5
2GS15M-4OS	28	Rp 1 1/4	680	1128	7,1	19,9
2GS22M-4OS	40	Rp 1 1/4	914	1412	10,1	25,2
2GS03T-4OS	7	Rp 1 1/4	280	612	2,9	10
2GS05T-4OS	10	Rp 1 1/4	332	685	3,5	11,1
2GS07T-4OS	14	Rp 1 1/4	402	755	4,2	12,4
2GS11T-4OS	20	Rp 1 1/4	507	885	5,3	14,6
2GS15T-4OS	28	Rp 1 1/4	680	1093	7,1	18,5
2GS22T-4OS	40	Rp 1 1/4	914	1362	10,1	23
2GS30T-4OS	52	Rp 1 1/4	1120	1568	12,2	26,1

2gs-4os-2p50_a_1d

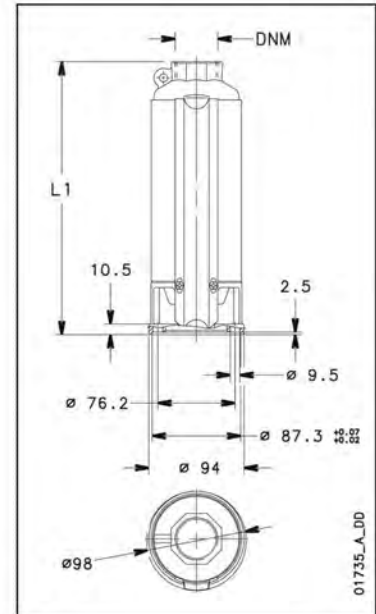

01735_A_00

2GS..L4C SERIES

Dimensions and weights

ELECTRIC PUMP TYPE *	NUMBER OF STAGES	DNM	DIMENSIONS (mm)		PUMP WEIGHT kg	ELECTRIC PUMP WEIGHT kg
			L1	L		
2GS02M-L4C	5	Rp 1 1/4	245	479	2,6	9,8
2GS03M-L4C	7	Rp 1 1/4	280	514	2,9	10,1
2GS05M-L4C	10	Rp 1 1/4	332	596	3,5	11,3
2GS07M-L4C	14	Rp 1 1/4	402	686	4,2	12,6
2GS11M-L4C	20	Rp 1 1/4	507	836	5,3	16,2
2GS15M-L4C	28	Rp 1 1/4	680	1071	7,1	19,8
2GS22M-L4C	40	Rp 1 1/4	914	1325	10,1	24,3
2GS03T-L4C	7	Rp 1 1/4	280	494	2,9	9,9
2GS05T-L4C	10	Rp 1 1/4	332	566	3,5	10,7
2GS07T-L4C	14	Rp 1 1/4	402	666	4,2	12
2GS11T-L4C	20	Rp 1 1/4	507	791	5,3	13,7
2GS15T-L4C	28	Rp 1 1/4	680	1026	7,1	19,1
2GS22T-L4C	40	Rp 1 1/4	914	1305	10,1	22,9
2GS30T-L4C	52	Rp 1 1/4	1120	1662	12,2	32,8

2gs-l4c-2p50_b_1d

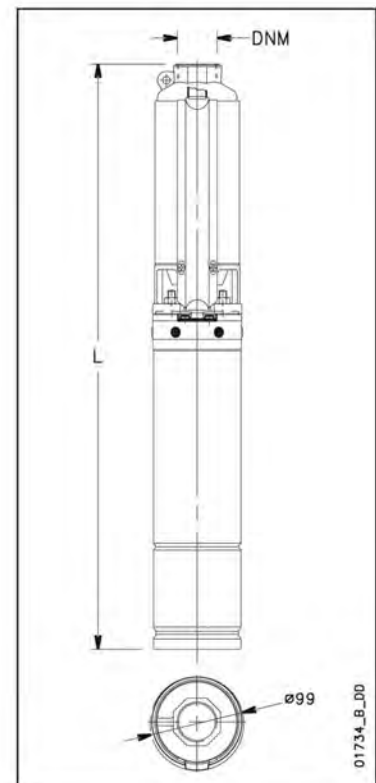

01734_B_00

* Electric pumps over 1500 mm long are supplied uncoupled.

Motor and pump are packed separately.

ORLANDO srl

2GS SERIES Operating characteristics at 50 Hz

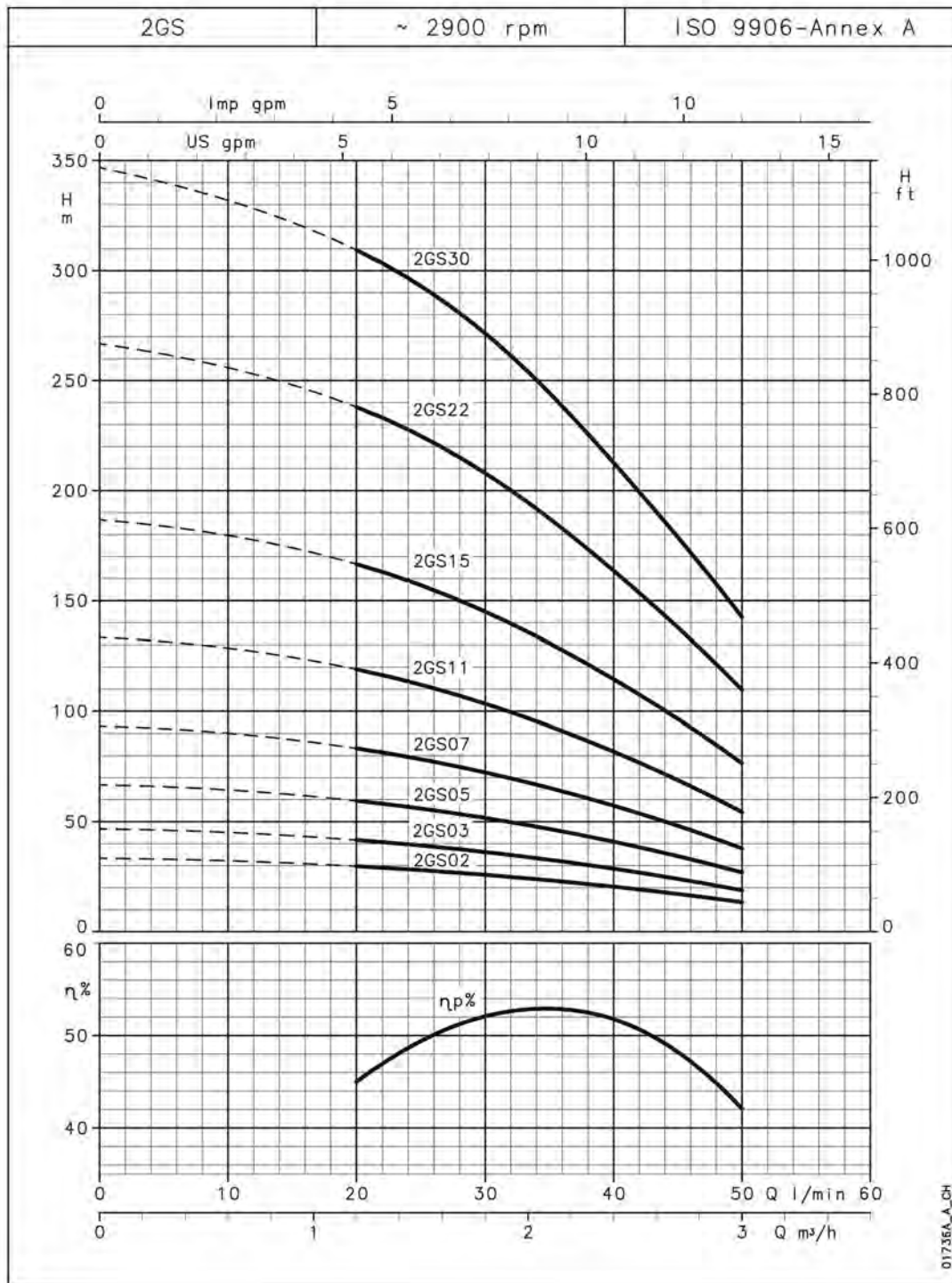

These performances are valid for liquids with density $\rho = 1.0 \text{ kg/dm}^3$ and kinematic viscosity $\nu = 1 \text{ mm}^2/\text{s}$.

4GS SERIES

Hydraulic performance table at 50 Hz

PUMP TYPE	NUMBER OF STAGES	RATED POWER		Q = DELIVERY					
		kW	HP	H = TOTAL HEAD IN COLUMN OF WATER (METRES)					
				l/min	0	30	40	60	80
4GS03M	4	0,37	0,5	27	24	23	19	13	9
4GS05M	7	0,55	0,75	47	42	40	33	22	15
4GS07M	9	0,75	1	60	54	51	42	28	19
4GS11M	14	1,1	1,5	94	84	80	66	44	30
4GS15M	19	1,5	2	127	114	108	89	60	40
4GS22M	27	2,2	3	181	162	154	127	85	57
4GS30T	35	3	4	228	204	194	160	107	72
4GS40T	48	4	5,5	321	288	274	226	151	102

4gs-2p50_n_th

4GS..4OS SERIES

Dimensions and weights

ELECTRIC PUMP TYPE *	NUMBER OF STAGES	DNM	DIMENSIONS (mm)		PUMP WEIGHT kg	ELECTRIC PUMP WEIGHT kg
			L1	L		
4GS03M-4OS	4	Rp 1 1/4	245	598	2,5	10,1
4GS05M-4OS	7	Rp 1 1/4	309	662	3,1	11,3
4GS07M-4OS	9	Rp 1 1/4	352	730	3,5	12,8
4GS11M-4OS	14	Rp 1 1/4	460	873	4,6	15,8
4GS15M-4OS	19	Rp 1 1/4	568	1016	5,7	18,5
4GS22M-4OS	27	Rp 1 1/4	770	1268	7,6	22,7
4GS03T-4OS	4	Rp 1 1/4	245	577	2,5	9,6
4GS05T-4OS	7	Rp 1 1/4	309	662	3,1	10,7
4GS07T-4OS	9	Rp 1 1/4	352	705	3,5	11,7
4GS11T-4OS	14	Rp 1 1/4	460	838	4,6	13,9
4GS15T-4OS	19	Rp 1 1/4	568	981	5,7	17,1
4GS22T-4OS	27	Rp 1 1/4	770	1218	7,6	20,5
4GS30T-4OS	35	Rp 1 1/4	967	1415	9,6	23,5
4GS40T-4OS	48	Rp 1 1/4	1248	1816	12,8	30,6

4gs-4os-2p50_a_fd

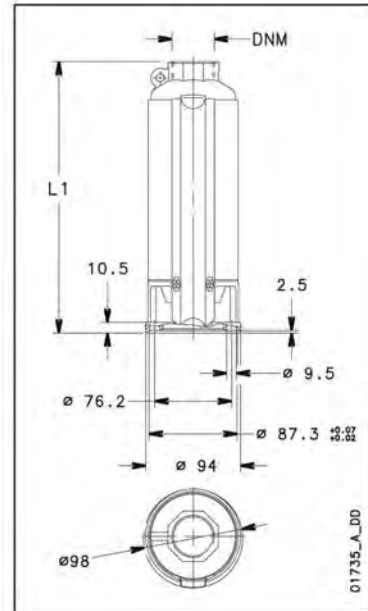

01735_A_DD

4GS..L4C SERIES

Dimensions and weights

ELECTRIC PUMP TYPE *	NUMBER OF STAGES	DNM	DIMENSIONS (mm)		PUMP WEIGHT kg	ELECTRIC PUMP WEIGHT kg
			L1	L		
4GS03M-L4C	4	Rp 1 1/4	245	479	2,5	9,7
4GS05M-L4C	7	Rp 1 1/4	309	573	3,1	10,9
4GS07M-L4C	9	Rp 1 1/4	352	636	3,5	11,9
4GS11M-L4C	14	Rp 1 1/4	460	789	4,6	15,5
4GS15M-L4C	19	Rp 1 1/4	568	959	5,7	18,4
4GS22M-L4C	27	Rp 1 1/4	770	1181	7,6	21,8
4GS03T-L4C	4	Rp 1 1/4	245	459	2,5	9,5
4GS05T-L4C	7	Rp 1 1/4	309	543	3,1	10,3
4GS07T-L4C	9	Rp 1 1/4	352	616	3,5	11,3
4GS11T-L4C	14	Rp 1 1/4	460	744	4,6	13
4GS15T-L4C	19	Rp 1 1/4	568	914	5,7	17,7
4GS22T-L4C	27	Rp 1 1/4	770	1161	7,6	20,4
4GS30T-L4C	35	Rp 1 1/4	967	1509	9,6	30,2
4GS40T-L4C	48	Rp 1 1/4	1248	1860	12,8	36,5

4gs-l4c-2p50_a_id

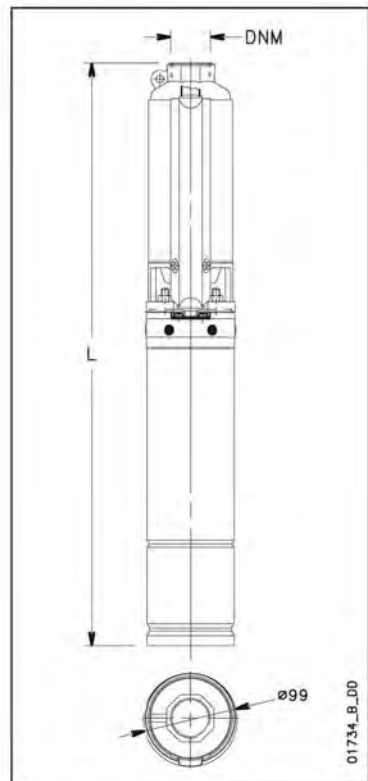

01734_B_DD

* Electric pumps over 1500 mm long are supplied uncoupled.

Motor and pump are packed separately.

ORLANDO srl

4GS SERIES

Operating characteristics at 50 Hz

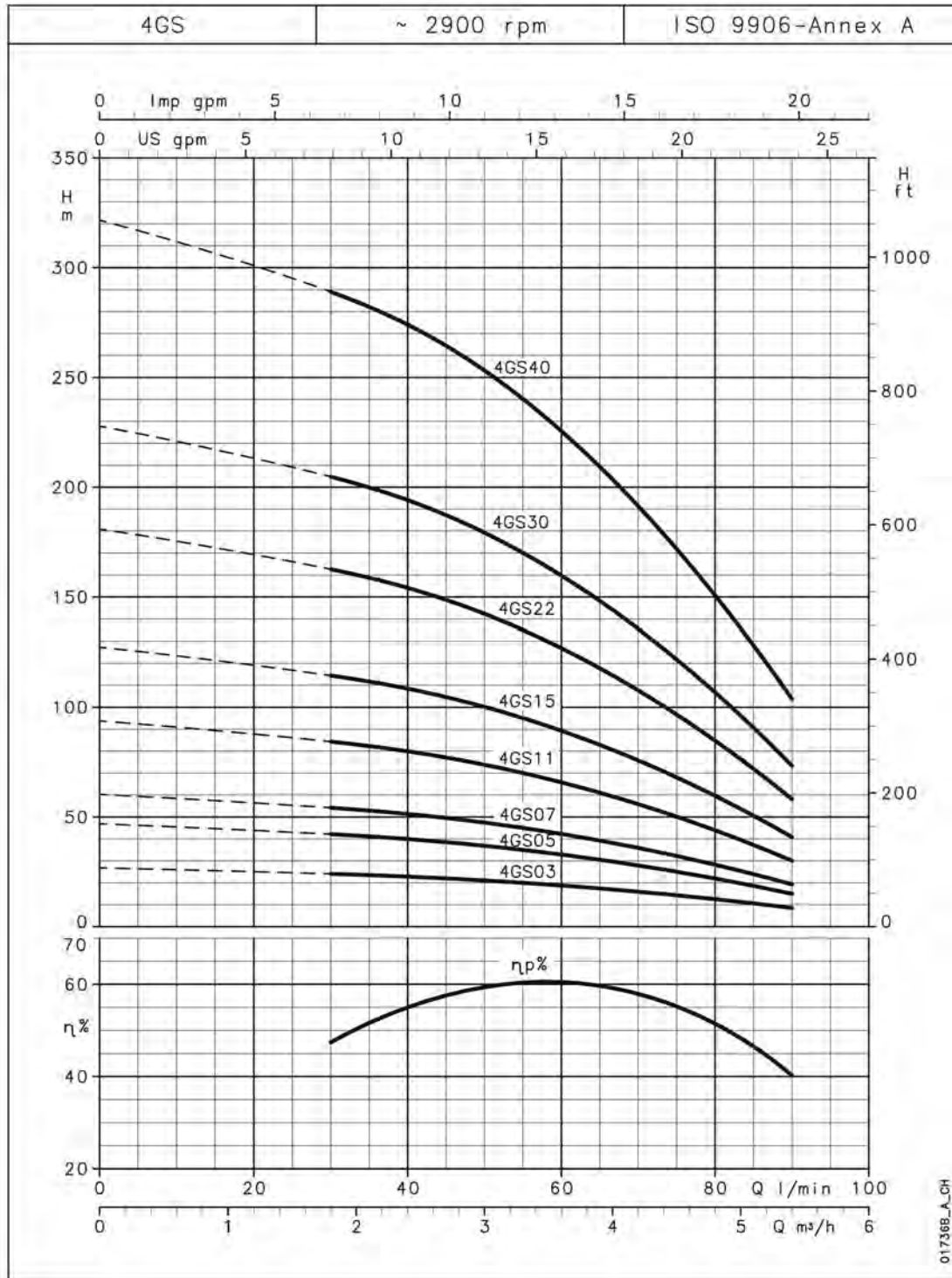

These performances are valid for liquids with density $\rho = 1.0 \text{ kg/dm}^3$ and kinematic viscosity $\nu = 1 \text{ mm}^2/\text{s}$.

5" SUBMERSIBLE MONOBLOC PUMP



APPLICATIONS

Multistage Submersible pump, designed to handle clean water at a maximum temperature of 35°C. Particularly suited for irrigation, water boosting, water transfer, emptying flooded cellars or rooms along with many other water duties for both civil and industrial applications. The units work well even in low water level.

SPECIFICATIONS: Manufactured in stainless steel to the highest quality and standards following extensive electrical and hydraulic tests. Max numbers of intervention 40/h - Max content of sand 60 gr/m³

MATERIALS: Pump and motor body, handle, cover and screen in AISI 304 stainless steel. Brackets in forged brass - Impellers, diffusers and separators in reinforced PPO - Each pump stage is fitted with a stainless steel ring for wear resistance - The motor shaft is in stainless steel AISI 430 - The mechanical seal is in Alumina/graphite, oil lubricated (Silicone Carbide seal available on request)

MOTOR: Asynchronous, single-phase 230V - 50Hz or three-phase 400V - 50Hz. Other voltage's or frequency available on request - F insulation class - Internal cooling is by a non polluting mineral oil. External cooling is via the pumped fluid. Built-in overload protection

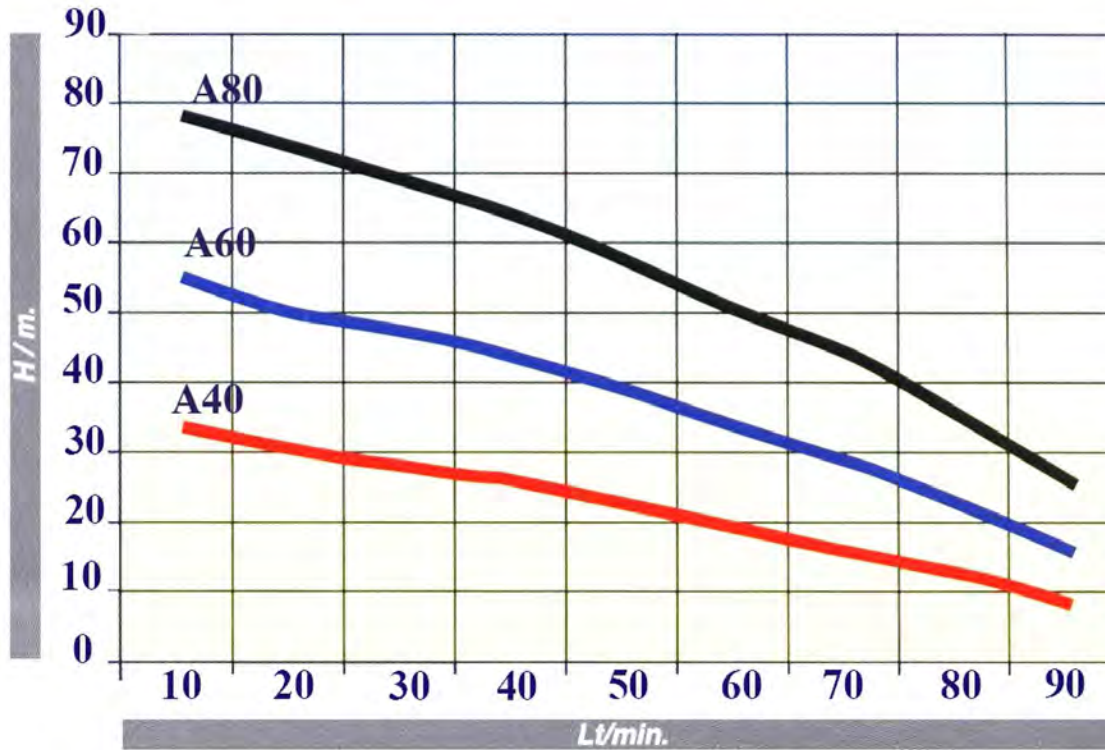

TIPO / TYPE		P ₂ nom.		P ₁ (kW) max.	AMPERE		CONDENSATORE CAPACITOR CONDENSATEUR uf	Q = PORTATA / CAPACITY / DEBIT											
1~ 220V - 50Hz	3~ 400 V - 5" Hz	kW	HP		1~	3~		m ³ h	0.6	1.2	1.8	2.4	3	3.6	4.2	4.8	5.4		
								Prevalenza manometrica totale in m.C.A. / Total head in meters w.c.											
								10	20	30	40	50	60	70	80	90			
PS 5 A40G ORLS	PS 5 A40T ORLS	0.6	0.8	900	4		20	34	31	28	26	23	20	16	13	9			
PS 5 A60G ORLS	PS 5 A60T ORLS	0.9	1.2	1400	6		31.5	55	50	47	44	39	34	29	23	16			
PS 5 A80G ORLS	PS 5 A80T ORLS	1.2	1.6	1800	8		40	78	74	69	64	57	50	44	35	26			

G = with float switch / avec flotteurs / con galleggiante



5" BORE-HOLE PUMPS

Pulsar pumps, which are very silent running, can be installed inside boreholes and sumps and eliminates all potential problems of suction and unpriming.

Multi-stage close-coupled borehole pump with hydraulic section below motor, which is cooled by the pumped liquid. Impellers, diffusers, strainers and oil sump in abrasion-proof thermoplastic. Outer liner, stator sleeve, upper head with delivery connection and closing ring in Aisi 304 stainless steel. Rotor shaft extension in AISI 304. Elastomers in NBR. Stainless steel screws.

Double mechanical seal with interposed oil chamber, made of ceramic/carbon on motor side and silicon carbide/silicon carbide on pump side. Submersible with continuous duty asynchronous motor. Rotor running on ball bearings, oversized to ensure low noise and durability built-in thermal and current overload protection and a capacitor permanently on in the single-phase version. To protect the three-phase motor use remote overload cut-outs in compliance with statutory regulations.

Constructed in compliance with CEI 2-3 and CEI 61-69 (EN 60335 -2-41) standards

Operating range: from 0.9 to 7.2 m³/h with head up to 86 metres

Maximum permissible sand quantity: 50 g/m³

Motor protection level: IP 68

Insulation class: F

Liquid temperature range: from 0°C to +40°C

Standard cables: 20 m H07 RNF cable type

Cable complete with Schuko plug EEC-7-VII-UNEL 47166-68 for the single-phase version. Single-phase version can be equipped with or without float switches for automatic operation.

MODEL	CODE	ELECTRICAL DATA						CAPACITY									
		VOLTAGE 50Hz	P1 kW	P2		In A	CAPACITOR		Q m ³ /h l/min	H (m)							
				kW	HP		µF	Vc		0	1,2	2,4	3,6	4,8	6	7,2	
PULSAR 30/50 M-A	104160000	1x230 V~	0,94	0,55	0,75	4,5	16	450	42	38,2	33,6	24,8	13,5				
PULSAR 30/50 M-NA	104160010	1x230 V~	0,94	0,55	0,75	4,5	-	-									
PULSAR 30/50 T-NA	104160420	3x230 V~	0,87	0,55	0,75	2,85	-	-	56	51	45	33	18				
PULSAR 30/50 T-NA	104160020	3x400 V~	0,87	0,55	0,75	1,65	-	-									
PULSAR 40/50 M-A	104160030	1x230 V~	1,12	0,75	1	5,2	16	450	72	65,5	58	45,6	24,5				
PULSAR 40/50 M-NA	104160040	1x230 V~	1,12	0,75	1	5,2	-	-									
PULSAR 40/50 T-NA	104160450	3x230 V~	1,03	0,75	1	3,2	-	-	86	78,5	70	52,8	29				
PULSAR 40/50 T-NA	104160050	3x400 V~	1,03	0,75	1	1,85	-	-									
PULSAR 50/50 M-A	104160060	1x230 V~	1,45	1	1,36	6,5	25	450	51	48,2	44,8	39,2	32,4	23,5	13		
PULSAR 50/50 M-NA	104160070	1x230 V~	1,45	1	1,36	6,5	-	-									
PULSAR 50/50 T-NA	104160480	3x230 V~	1,35	1	1,36	4,15	-	-	64	61	56,6	50	41,5	30,5	16,2		
PULSAR 50/50 T-NA	104160080	3x400 V~	1,35	1	1,36	2,4	-	-									
PULSAR 65/50 M-A	104160090	1x230 V~	1,70	1,2	1,6	7,8	30	450	77	73,2	68	60	50	37	19,6		
PULSAR 65/50 M-NA	104160100	1x230 V~	1,70	1,2	1,6	7,8	-	-									
PULSAR 65/50 T-NA	104160510	3x230 V~	1,60	1,2	1,6	5	-	-									
PULSAR 65/50 T-NA	104160110	3x400 V~	1,60	1,2	1,6	2,9	-	-									
PULSAR 30/80 M-A	104160230	1x230 V~	1,12	0,75	1	5,2	16	450									
PULSAR 30/80 M-NA	104160240	1x230 V~	1,12	0,75	1	5,2	-	-									
PULSAR 30/80 T-NA	104160650	3x230 V~	1,03	0,75	1	3,2	-	-									
PULSAR 30/80 T-NA	104160250	3x400 V~	1,03	0,75	1	1,85	-	-									
PULSAR 40/80 M-A	104160260	1x230 V~	1,45	1	1,36	6,5	25	450									
PULSAR 40/80 M-NA	104160270	1x230 V~	1,45	1	1,36	6,5	-	-									
PULSAR 40/80 T-NA	104160680	3x230 V~	1,35	1	1,36	4,15	-	-									
PULSAR 40/80 T-NA	104160280	3x400 V~	1,35	1	1,36	2,4	-	-									
PULSAR 50/80 M-A	104160290	1x230 V~	1,70	1,2	1,6	7,8	30	450									
PULSAR 50/80 M-NA	104160300	1x230 V~	1,70	1,2	1,6	7,8	-	-									
PULSAR 50/80 T-NA	104160710	3x230 V~	1,60	1,2	1,6	5	-	-									
PULSAR 50/80 T-NA	104160310	3x400 V~	1,60	1,2	1,6	2,9	-	-									

A = automatic with float switch NA = manual without float switch

ORLANDO srl

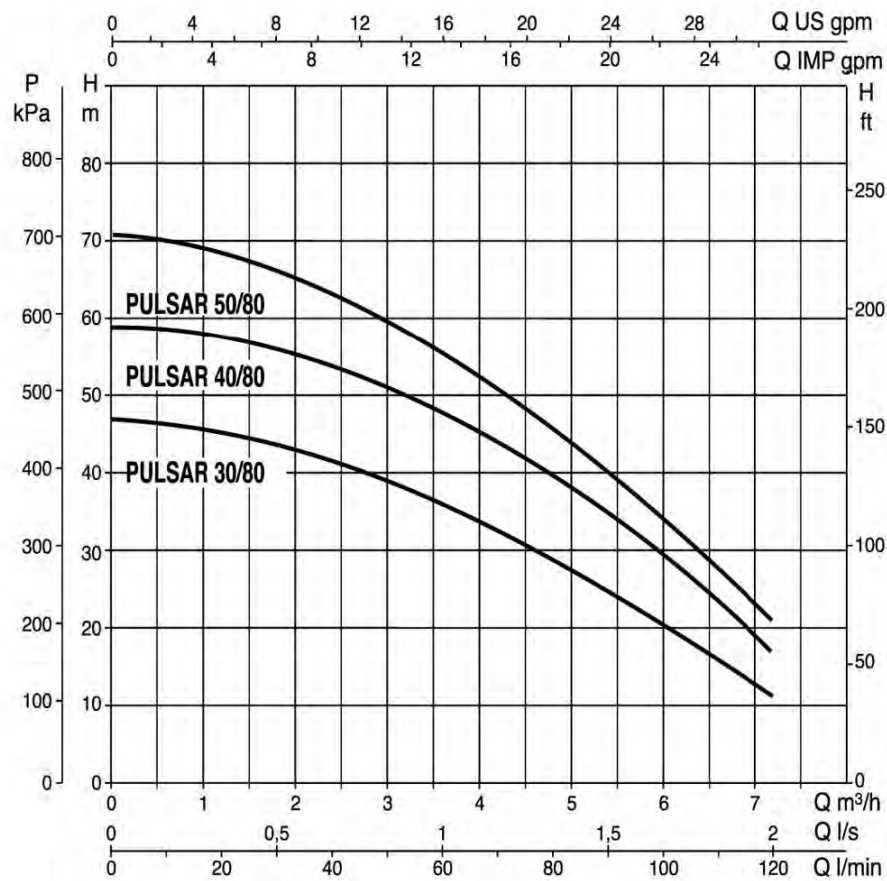
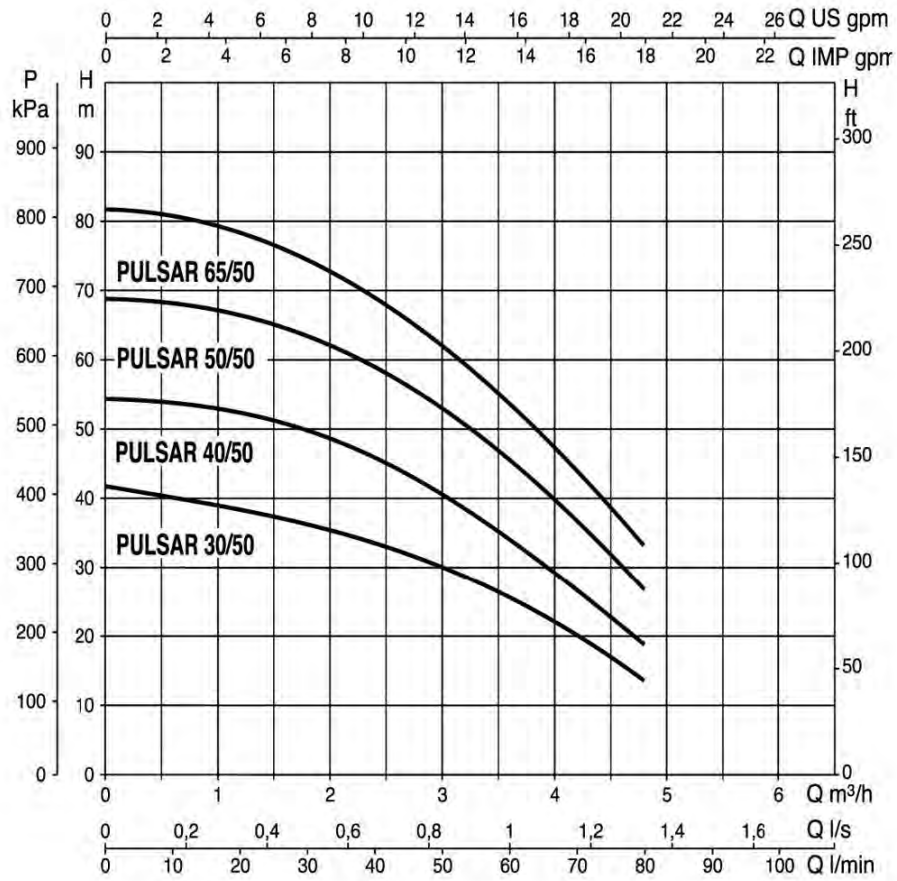

ORLANDO srl

SCUBA Series

Multi-stage submersible centrifugal pumps for clean water, with the majority of components in AISI 304 stainless steel. Double mechanical seal system with oil chamber.

The liquid end is located underneath the electric motor which is cooled by the pumped liquid.

The pump is directly inserted in the tank or well to avoid suction problems and noise. Can also operate in a horizontal position.

Specifications

Delivery: up to 7.5 m³/h

Head: up to 80 metres

Power supply: three-phase and single-phase 50 and 60 Hz

Single-phase motor: 220-240 V

50Hz, built-in automatic reset overload protection. Internal capacitor supplied standard.

Three-phase motor: 380-415 V; overload protection to be provided by user and installed in the control box (see control box section)

Power: 0.55 kW to 1.1 kW

Maximum immersion depth: 20 metres

Water temperature: 0°C to +40°C

Passage of solids: up to 2.5 mm

Maximum permissible quantity of suspended sand: 25 g/m³

Materials

Sleeve and head: Stainless steel

Upper bearing support:

Stainless steel

Shaft extension: Stainless steel

Screws: Stainless steel

Impeller: Technopolymer

Diffuser: Stainless steel

Lower bearing support: Die-cast aluminium

Elastomers: NBR

Applications

Water supply from tanks, 6" wells, basins and watercourses

Pressure boosting

Irrigation

Rain water collection



ORLANDO orl

SCUBA SERIES

Operating characteristics at 50 Hz

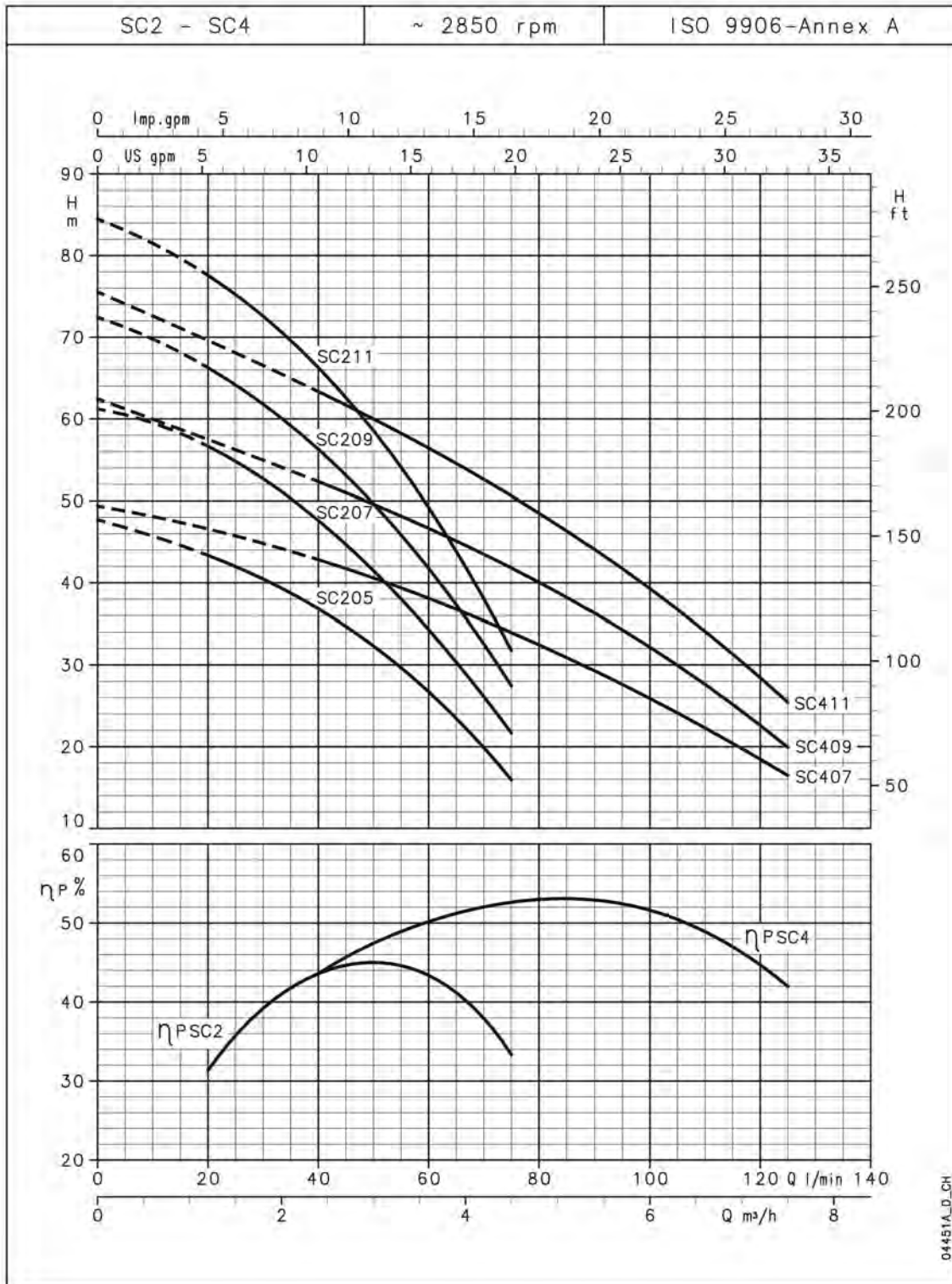

These performances are valid for liquids with density $\rho = 1.0 \text{ kg/dm}^3$ and kinematic viscosity $\nu = 1 \text{ mm}^2/\text{s}$.

ORLANDO srl

SCUBA SERIES Dimensions and weights

PUMP TYPE		NUMBER OF STAGES	DIMENSIONS		WEIGHT kg
SINGLE-PHASE	THREE-PHASE		L mm		
SC205C	SC205T	4	526	13,5	
SC207C	SC207T	5	566	15	
SC209C	SC209T	6	591	16	
SC211C	SC211T	7	636	18	
SC407C	SC407T	4	541	14,5	
SC409C	SC409T	5	566	15,5	
SC411C	SC411T	6	611	17,5	

scuba-sc2-sc4-2p50_c_ld

PUMP TYPE	CROSS-SECTION	CABLE TYPE	LENGTH OF CABLE
SC205C	3G1	H07RN-F	20 m
SC207C	3G1	H07RN-F	
SC209C	3G1,5	H07RN-F	
SC211C	3G1,5	H07RN-F	
SC407C	3G1	H07RN-F	
SC409C	3G1,5	H07RN-F	
SC411C	3G1,5	H07RN-F	
SC205T	4G1	H07RN-F	
SC207T	4G1	H07RN-F	
SC209T	4G1	H07RN-F	
SC211T	4G1	H07RN-F	
SC407T	4G1	H07RN-F	
SC409T	4G1	H07RN-F	
SC411T	4G1	H07RN-F	

scuba-sc2-sc4-2p50_c_lc

Single-phase range available with pre-mounted float switch (SCUBA G). Versions with 10 metre cables available on request.

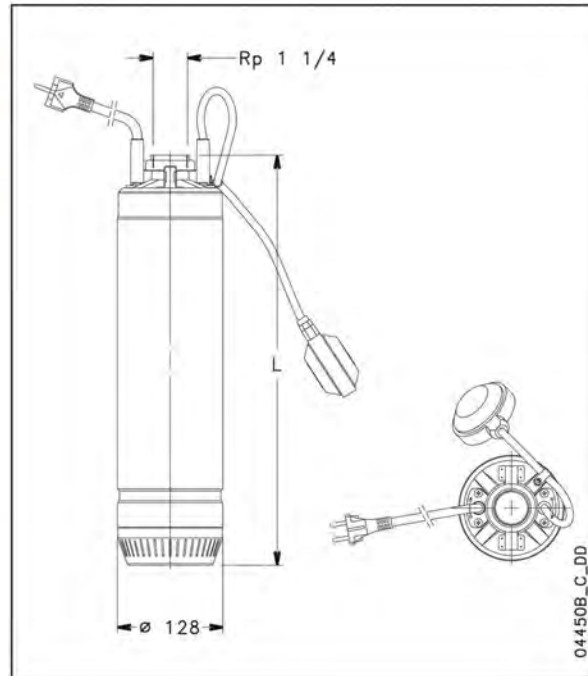

04450B_C_DD

Hydraulic performance table at ~2850 rpm 50 Hz

PUMP TYPE	RATED POWER		Q = DELIVERY													
			l/min		30		50		75		100		125			
			0	20	1,8	2,4	3	3,6	4,5	4,8	6	7,5				
			H = TOTAL HEAD IN COLUMN OF WATER (METRES)													
			0	1,2												
SC205C - SC205T	0,55	0,75	47,7	43,4	40,5	36,8	32,3	26,7	15,9							
SC207C - SC207T	0,75	1	61,2	56,7	52,7	47,6	41,5	34,3	21,7							
SC209C - SC209T	0,9	1,2	72,4	66,3	61,8	56,3	49,6	41,8	27,4							
SC211C - SC211T	1,1	1,5	84,5	77,6	72,6	66,3	58,6	49,2	31,7							
SC407C - SC407T	0,75	1	49,4			42,8	40,6	38,1	34,0	32,5	25,9	16,5				
SC409C - SC409T	0,9	1,2	62,5			52,3	49,6	46,7	41,8	40,1	32,2	19,9				
SC411C - SC411T	1,1	1,5	75,5			63,4	60,0	56,4	50,6	48,5	39,3	25,4				

scuba-sc2-sc4-2p50_c_th

Electrical data

PUMP TYPE	INPUT POWER*	INPUT CURRENT*	CAPACITOR
SINGLE-PHASE		220-240 V	
	kW	A	µF / 450 V
SC205C	0,93	4,37	16
SC207C	1,15	5,19	25
SC209C	1,32	5,88	25
SC211C	1,63	7,25	30
SC407C	1,18	5,28	25
SC409C	1,38	6,17	25
SC411C	1,76	7,85	30

*Maximum value in specified range.

PUMP TYPE	INPUT POWER*	INPUT CURRENT*	INPUT CURRENT*
THREE-PHASE		220-240 V	380-415 V
	kW	A	A
SC205T	0,86	2,81	1,62
SC207T	1,09	4,12	2,38
SC209T	1,27	4,40	2,54
SC211T	1,45	4,68	2,70
SC407T	1,12	4,16	2,40
SC409T	1,33	4,50	2,60
SC411T	1,59	4,94	2,85

scuba-sc2-sc4-2p50_c_te

INSTALLATION EXAMPLE OF A SUBMERSIBLE PUMP Controlled by an inverter (hydrovar® Watercooled)

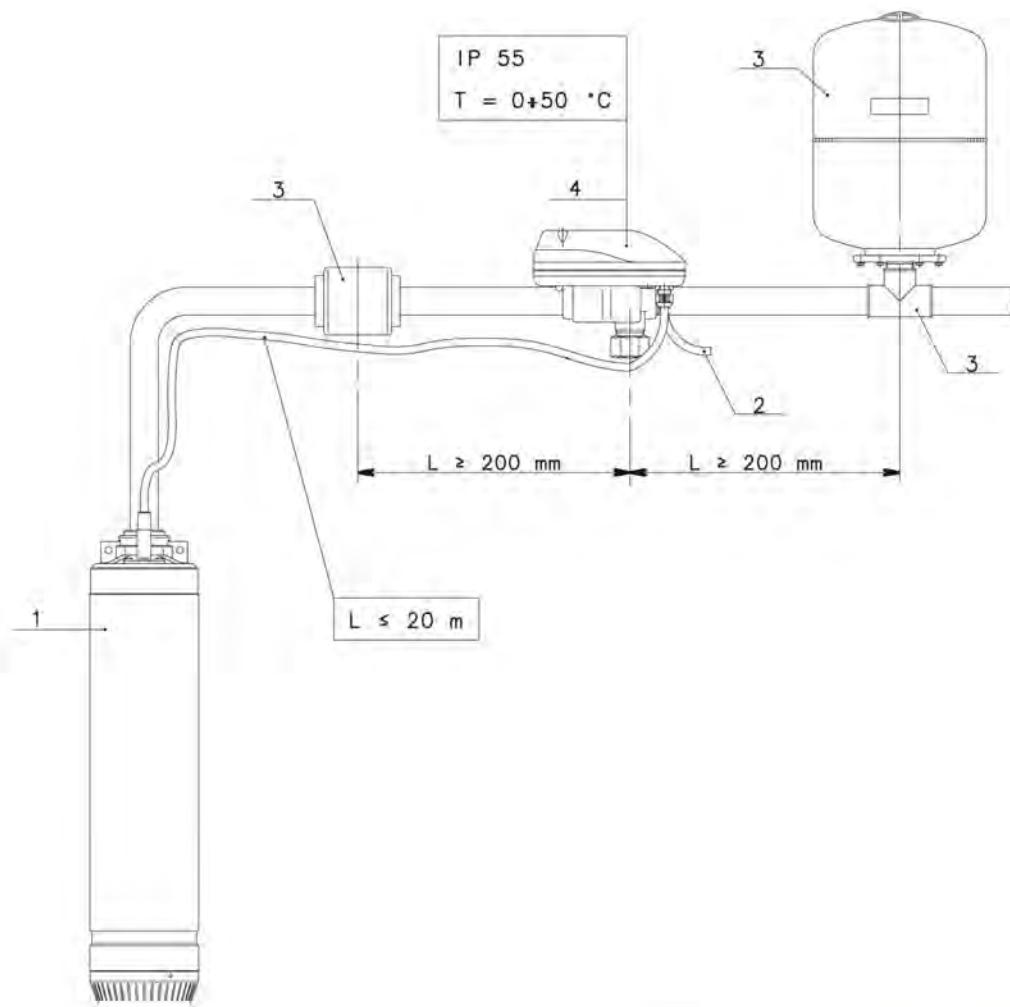

REF.	DESCRIPTION
1	Scuba/B electric pump
2	Power cable
3	HVV hydraulic kit
4	Hydrovar® Watercooled inverter

scuba-hvv-2p50_a_1p.