DOMOTECH



① **Manuale istruzioni**

Ⓒ **Instruction Manual**

INTRODUCTION

The DOMOTECH series inverters ensure constant pressure to the water supply system thanks to the use of PWM modulation technology and the DSP digital processor. By using a frequency inverter combined with pressure detecting technology, the EASY inverter can adjust the motor speed in real time by monitoring the changes in the piping network and adjusting the output pressure accordingly, in order to assure water and electricity savings.

sector of use

It may be used to supply water to tall buildings, restaurants, hotels, residential areas etc...

advantages of use

1. The product is based on 3 international patents, the main of which is the PID algorithm controlling motor rotation.
 2. Energy efficiency. Comparing it with traditional supply systems, the use of the constant pressure inverter provides energy savings from 30% up to 60%.
 3. Simple to use. All functions may be set up from a single button, without the need for specialised personnel.
 4. Long lasting. The torque and drive shaft consumption is lowered thanks to the reduction of average motor speed.
- Thanks to the gradual start-up and stop, the inverter removes the water hammer, which would cause severe damage to the entire water system.

5. Global protection. The DOMOTECH series inverters are equipped with the best global protection against overcurrent, overvoltage, undervoltage, short circuit, rotor block, etc ...

6. Safety and attention to the environment. The product complies with the European and USA standards regarding safety, quality standards and environmental protection.

information on use

1. Carefully read this booklet before installation and use.

2. Before starting the product, make sure earthing has been performed.

3. Pay particular attention to the symbols used in this booklet.

General electrical hazard risk. If ignored, it may cause damage to the electrical pump and to persons.

Hazard caused by electrical equipment. If ignored, it may cause damage to the electrical pump and to persons.

4. Any damage caused by failure to comply with the instructions and safety measures provided in this booklet shall not be borne by our company, but exclusively by those who have ignored the standards.

GENERAL SAFETY INDICATIONS

be sure to use the correct electrical power supply required by the product

During installation and maintenance, make sure to have disconnected general power. Before using the product, make sure correct earthing has been set up.

If the pump remains inactive for a long time, close the water supply valve and disconnect the electrical power supply.

Do not install the electrical pump in locations that might get exposed to water.

If the product remains unused for 2 years, gradually increase the pressure via the voltage regulator, since there is the risk of receiving an electric shock.

Do not touch the control terminals when the equipment is on since there is the risk of receiving an electric shock.

Maintenance must be performed five minutes after equipment shut-down. The relative indicator must be fully off in order to not receive an electric shock.

Make sure your hands are completely dry before using the control panel, in order to not risk receiving an electric shock.

If wiring or wires are worn, have them replaced by qualified personnel.

Product installation and use must comply with the standards in force.

Installation and maintenance must be performed by qualified personnel who have read this booklet.

If the motor overheats in an abnormal manner, immediately close the water supply valve and disconnect the electrical power supply and contact the service centre or the dealer.

Do not start the electrical pump until the problem is resolved.

In case of malfunction, immediately close the water supply valve and disconnect the electrical power supply and contact the service centre or the dealer.

Do not start the electrical pump until the problem is resolved.

Make sure to keep this product away from children and take all necessary precautions so that they do not come into contact with the equipment.

the product must be positioned in a fresh, dry and ventilated environment with room temperature.

Ventilate premises when too hot and prevent condensate, which may cause electrical failures, from forming

Make sure your hands are completely dry before using the control panel, in order to not risk receiving an electric shock.

PRELIMINARY CHECK

product control

Each unit of this product is checked before leaving the factory. Customers receiving the inverters should however check that:

1. The correct model has been delivered.
2. There is no damage caused by transport. If there is, do not turn on the inverter.

information regarding environmental conditions

The conditions of the environment in which the inverter is installed affect its operating duration.

Therefore make sure the following conditions are met:

- The product must be used indoors at a temperature between -10 C° ~ $+40\text{ C}^{\circ}$;
- The premises must well ventilated and not humid, away from fuels and radioactive materials;
- Make sure there is no electromagnetic interference caused for example by dust, fine metals and fabrics.

APPEARANCE AND DIMENSIONS

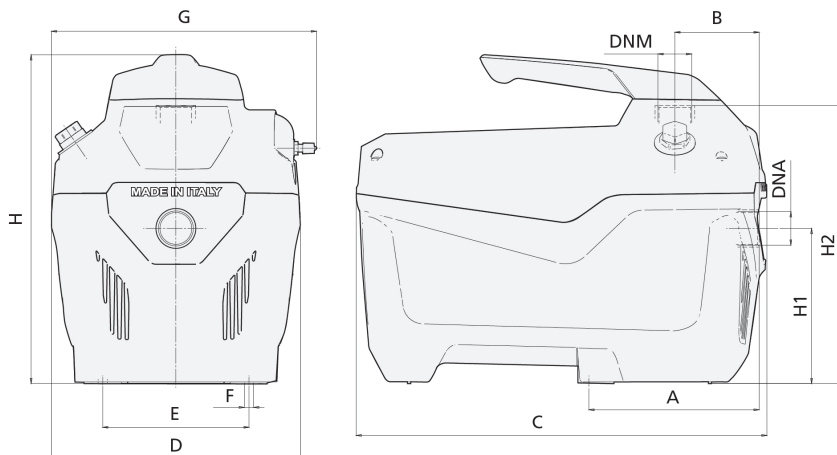

TIPO TYPE	DIMENSIONI mm - DIMENSIONS mm												
	A	B	C	D	E	F	G	H	H1	H2	GIRANTI IMPELLERS	DNA	DNM
Monofase Single-phase													
DOMOTECH 1000	163	81	393	238	140	9	254	315	149	266	4	1"	1"

DOMOTECH 1.1 kW inverter

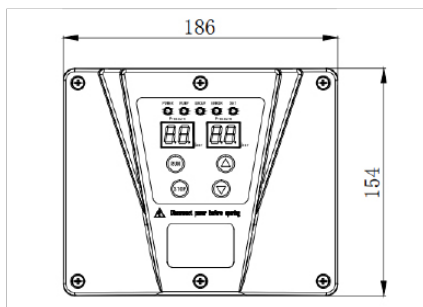
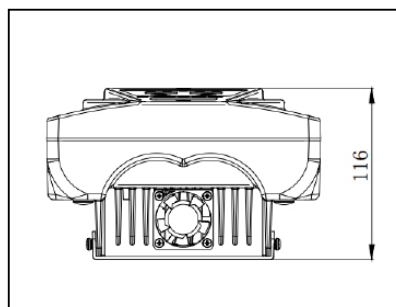

TECHNICAL DATA

DOMOTECH INVERTER 1.1 kW	
Power supply	Single-phase - three-phase AC (alternating
Input voltage	1X230V AC or 3x400V AC
Frequency	50 - 60 Hz
Electric pump type	Three-phase 3X230V or 3X400V AC
Output frequency	20~50Hz or 20~60Hz
Pressure sensor	24 V 4-20mA
Pressure sensor interval	10bar
Pressure setting interval	From 1 Bar to the maximum range of the pressure sensor * 90%
System configuration required	It is necessary to use a hydrosphere of more than 4 litres on the pipe system (internal pressure must be at 60% of the setting)
Room temperature	0 ~+ 40 °C
Usable liquid	Clean water at temperature from 0 ~+ 40 °C
Startup delta for automatic start	Factory settings are adjusted at 0.3 Bar
Configuration requirements	Before using the product, make sure correct earthing has been set up.

INSTALLATION

Under head

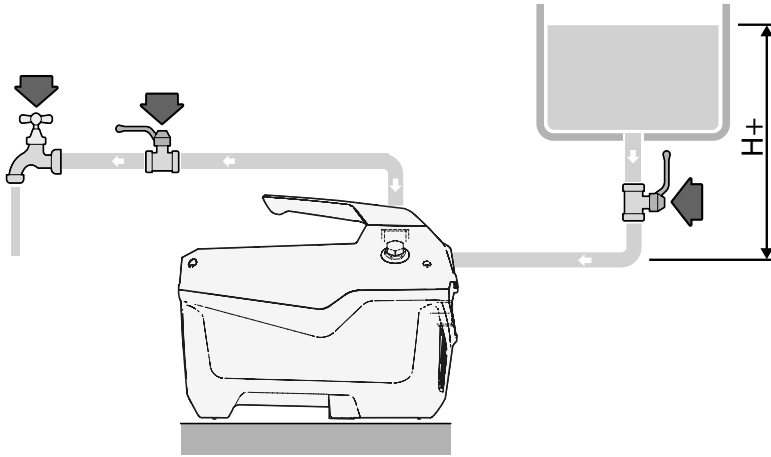

Above head

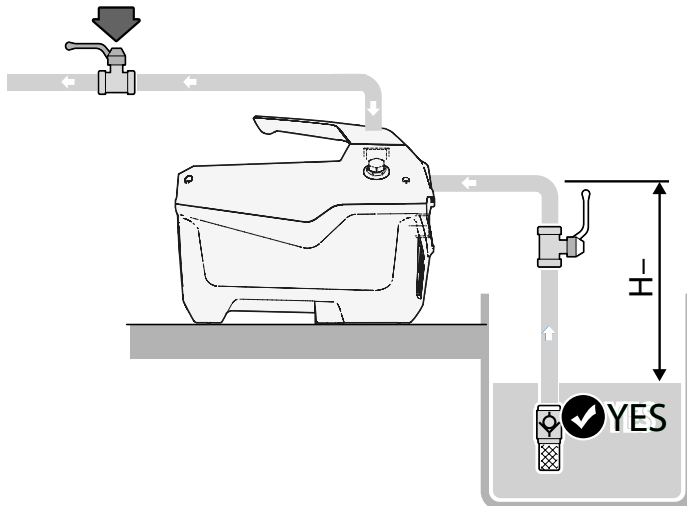

FILLING INSTRUCTIONS



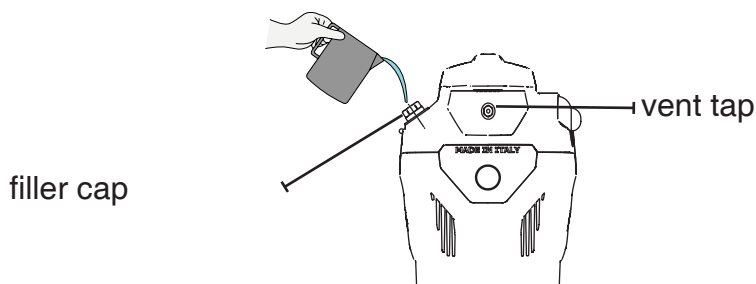

1. open filler cap and vent tap.
2. insert water until it flows out of the vent tap.
3. close the filler cap and vent tap.



Use

1. check that the input current and that the environment in which the inverter is installed are compatible with the use conditions.
2. check that the pressure sensor is connected to the system.
3. ensure that all connections are fully tightened.

OPERATING STEPS

1. When connecting the current, the start-up indicator will turn on and the pressure display will show 00.00 Bar.
2. Open the delivery valves and press the button  and start the pump.
3. Press  at any time to stop the pump.
4. Press  or  to:
 - set the operating pressure.
 - increase or decrease the set pressure.
5. Open the tap after adjusting the pressure and the inverter will adjust pump speed based on the water use. If the pump operates normally and the pressure indicated on the display is constant, installation is complete.

KEYS AND FUNCTIONS GUIDE

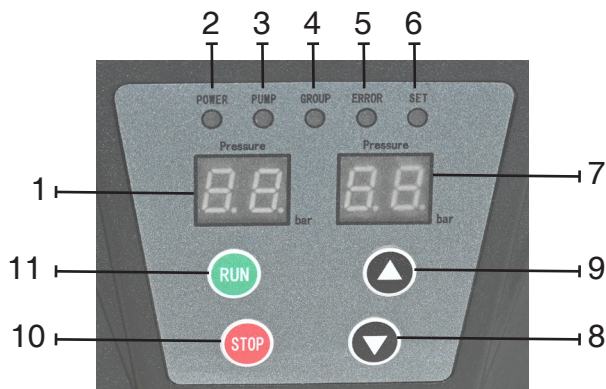

No.	Name	Description
1	Pressure	Indicates the current pressure in Bar
2	Power	power led: if the light is on steady, the power supply is on
3	Pump	Pump operation status LED. ashing:pump running steady: pump not running off: the STOP button was pressed
4	Group	The LED lights up when more than one pump is connected
5	Error	the LED lights up in the event of a water shortage, the system is restarted every: 10s-1min-5-min-30min-1h-2h-3h-4h
6	Set	Pressure setting LED by pressing the UP and DOWN buttons the LED will flash: if the button is not pressed for 8 seconds the LED will switch off
7	Pressure	Indicates the set pressure in bar (3 bar factory setting)
8	Down (-)	each press decreases the value by 0.1 bar
9	Up (+)	Each press increases the value by 0.1 bar
10	Stop	Manual stop of electric pump
11	Run	Manual start-up of the electric pump

ERROR CODES

No.	Name	Description
OH	Overheating protection	When the inverter temperature exceeds the temperature value set by P020, it will display the protection ' OH '
OD	Overload protection	When the current exceeds the rated current by more than 1.6 times of the inverter at any power, it will display the protection ' OD '
OC/OL	Overcurrent protection	When the current exceeds the rated current by more than 3 times of the inverter at any power, it will display the protection " OC " or " OL "
uLU	Undervoltage protection	<p><u>110V level:</u> when the input voltage is below 80V, 'uLU' will be displayed returns to normal when the voltage is 90V</p> <p><u>220V level:</u> when the input voltage is below 160V, 'uLU' will be displayed returns to normal when the voltage is 175V</p> <p><u>380V level:</u> when the input voltage is below 280V, 'uLU' will be displayed returns to normal when the voltage is 320V</p>
uOU	Overvoltage protection	<p><u>110V level:</u> when the input voltage is above 145V, 'uOU' is displayed returns to normal when the voltage is 135V</p> <p><u>220V level:</u> when the input voltage is above 275V, 'uOU' is displayed returns to normal when the voltage is 260V</p> <p><u>380V level:</u> when the input voltage is above 280V 'uOU' will be displayed returns to normal when the voltage is 440V</p>

ERROR CODES

No.	Name	Description
OTP	Overpressure protection	<p><u>Level 10 bar</u>: when the pressure is above 9.9 bar, 'OTP' is displayed returns to normal when below 9.9 bar</p> <p><u>Level 16 bar</u>: when the pressure is above 15.9 bar, 'OTP' is displayed returns to normal when below 5.9 bar</p> <p><u>Level 25 bar</u>: when the pressure is above 24.9 bar, 'OTP' is displayed returns to normal when below 24.9 bar</p>
LTP	Sensor error	When the pressure sensor is defective or the pressure sensor wiring is disconnected, it will display 'LTP'
EL	communication error	When the display board and motherboard wiring are disconnected, 'EL' will be displayed
LP	Open phases protection	When the input or output power cable is disconnected, 'LP' will be displayed Three-phase installation. When one of the phases stops working, 'LP' will be displayed

MAINTENANCE

Maintenance must be performed by qualified personnel. Speroni shall not be liable in the event of tampering with/modification of settings by the user.



During summer, make sure the premises where the pump is installed are well ventilated, but that it is not exposed to direct sunlight or rain.

Precautions against freezing must be taken during winter, but do not use fuel materials.

If the pump is not used for a long time, disconnect from the current and keep it dry.

PROGRAM SETTINGS

The inverter can be calibrated when it is in Stop mode.

Press the Up  and Down  buttons simultaneously and hold them down for 3 seconds.

Now the desired parameters can be entered.

Press the “RUN” key  to confirm and save the settings.

If nothing is done, the system will reset to the previous parameters after 3 seconds.

With inverter running, technical data may be queried.

parameters range from P001-P004.

Code	Name	Function	Range	De-fault
P001	Displays the value of the current output frequency.			
P002	Displays the value of the current output current.			
P003	Displays the value of the current input voltage.			
P004	Displays the value of current temperature.			
P010	Restore factory settings	Press the <Up> and <Down> buttons to switch between '0' and '1'. The factory default value is displayed as '1' and will automatically change to 0 once any parameter is changed. When the value is '1' and the <Run> button is pressed, the factory default setting will be restored.	0 or 1	1
P011	Initial pressure difference setting.	It is possible to set the pressure value of automatic start-up, when the inverter shuts down automatically.	0.1~2 bar	0.3 bar
P012	Setting the parameter pressure due to lack of water.	This setting is used to stop the pump where there is low water, and thus prevent it from running dry. When the pressure of the delivery pipes remains at 0.1 bar for 3 seconds, the system will leave this mode and resume normal operation.	from 0 bar to the pressure set to which 0.4 bar must be subtracted. If left at 0 bar, the protection will not be triggered.	0.1 bar
P013	No water timing setting.	Based on the needs, a delay for the activation of the protection against dry operation can be set thanks to this parameter. The restart time after a water shortage shutdown can be 10 seconds, 1 minute, 5 minutes, 15 minutes, 30 minutes, 1 hour, 2 hours, 4 hours and a 4-hour cycle until the pressure returns to normal.	0 s~60 s	30 sec
P014	carrier frequency setting	With a higher value, the interference will be lower and the wave will have a harmonic pattern. At the same time, the higher the inverter frequency, the higher the IGBT temperature will be.	"L" is 6KHz for 2.2KW 8KHz when it is less than 2.2KW "H" is 8KHz for 2.2KW and 16KHz when it is less than 2.2KW	8KHz
P015	Adding or subtracting time	Acceleration and deceleration time setting range. Adjusting this parameter can speed up or slow down the increase in pressure	2~5 sec	2 sec

Code	Name	Function	Range	Default
P016	Pressure fluctuation interval	The setting of this parameter can improve keeping a constant pressure. It may be used in combination with the P011 parameter when managing operating pressure fluctuation and it may also stop the system based on how much water is present. It is however less effective than the start-up pressure, which has priority for starting the differential.	0-1 bar	0.1 bar
P017	Set the minimum shutdown frequency	With this parameter you may solve the problem of no stop due to pipes leaks. Pay particular attention when adjusting this parameter since it may cause frequent pump restarts. The parameter always goes at more than 30 Hz.	20Hz-40Hz	24Hz
P018	Stop setting	This enables stop if a certain pressure is reached	0 or 1 0:stop 1:stop not allowed	0
P019	Range selection setting	If the setting pressure is 1.0 mbar the pressure range is 0.5---9 bar if it is 1.6 mbar the pressure range is 0.5 ---- 15 bar if it is 2.5 mbar, the pressure range is 0.5 ---- 24 bar	1.0-1.6-2.5 mbar	1 mbar
P020	Overheating setting	It is possible to set the temperature which triggers the overheating protection The sensor checks the internal temperature of the inverter, and after it has been triggered, only starts it up again when it has dropped below 20°C	60- 90°C (if set on H, there is no protection)	85°C
P021	Clockwise or anti-clockwise rotation setting	It enables to select the pump rotation direction, it should be the same as the one for the motor.	0 or 1 0:stop 1:stop not allowed	0
P022	Main and supplementary pumps setting	With this setting you may specify the pumps sequence when they are in connected mode (from 2 to 6, with no repetition). After setting the parameter, turn off the system for 5 minutes and then turn it back on. The pump with the lower number is the main one.	2-6	1
P023	Rotation time	If the operating time coincides with the one set, the pumps will automatically alternate	0-72 hours	48 hours
P024	Maximum number of electric pumps operating simultaneously	The maximum number of pumps operating simultaneously can be set. The maximum number is 6. The number set operates with maximum water flow rate.	1 - 6	6

CONNECTIONS FOR 2-PUMP UNIT

It is possible to connect DOMOTECH in parallel via the jack cable (on request).

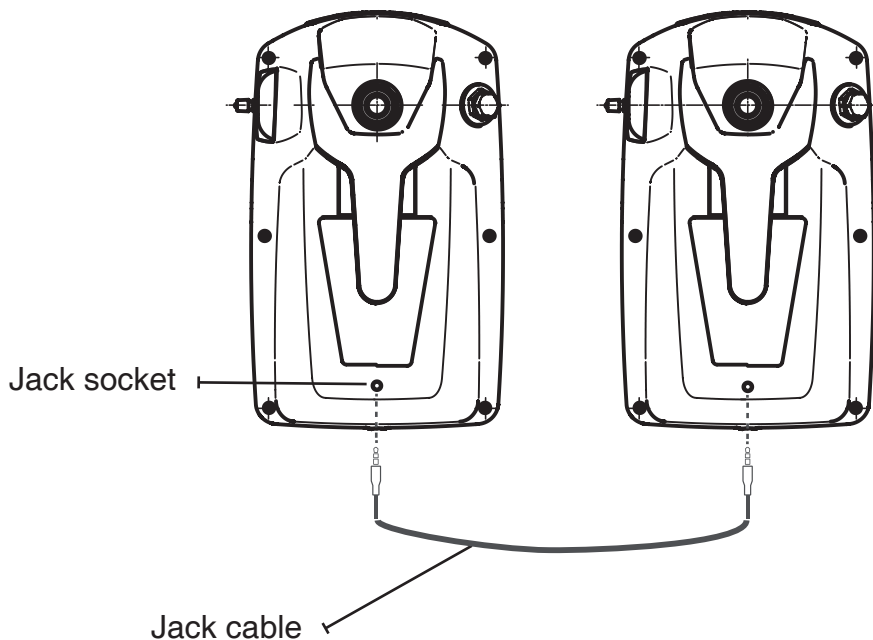

Press the **UP** and **DOWN** buttons of the first inverter simultaneously for 3 seconds to enter the subdirectory,

then press the **UP** button on **P022**

press the **RUN** button to confirm

press the **UP** button again to set the parameter to 2.

This inverter controls electric pump no. 1
(**P022 sets the inverter/pump number**).

CONNECTIONS FOR 2-PUMP UNIT

Carry out the previous operation on the second inverter to set it to parameter 3.

Enter the subdirectory of the first inverter and set it to **P023 (rotation time setting)**

set the cycle time to suit your needs

(The setting range is from 1 to 72 hours)

Enter the subdirectory of the first inverter again and set it to **P024 (set the number of machines to be connected)** set it to 2 if only 2 inverters are to be connected, and so on.

Make all settings

disconnect all inverters from the power supply.

Reconnect all inverters after 2 minutes.

When the **GROUP** LED of one of the inverters is always on, it indicates the main **MASTER** inverter.

If all **GROUP** LEDs on the inverter panel are lit, the connection signal is normal.

During operation, **only the buttons of the MASTER inverter (main) will be active.**

The buttons of the secondary inverter cannot be operated.

Press the RUN button on the MASTER inverter and the pumps will start running.

OPERATION FOR 2-PUMP UNIT



In unit operation, the reference pressure can only be set on the MASTER inverter, the inverters independently regulate the operation of one or two pumps depending on the amount of water required by the users.

DRY RUNNING

DOMOTECH pump management inverter electronics protect the pump against dry running.

When the red '**ERROR**' LED lights up, the pump stops within the specified time (point 5 page 13).

It is in any case possible, after checking the correct suction, to restart the pump using the **RUN** button

DRY RUNNING

The pump is equipped with a small diaphragm hydrosphere pre-charged to 1.5 bar, ensuring that the pump remains stopped for a sufficient amount of time in the event of dripping or leakage. If this is not sufficient, an additional hydrosphere can be installed in the delivery line.